



## Installation and Maintenance Manual

## IM 893-12

Group: Applied Air Systems

Part Number: IM 893-12

Date: November 2024

## RoofPak<sup>®</sup> Singlezone Heating and Cooling Units

RPS/RDT/RFS/RCS 015D—140D  
with MicroTech<sup>®</sup> Unit Controller  
and Refrigerant R-410A



Unit Nameplate . . . . .	3	DesignFlow™ Outdoor Air Damper Option . . . . .	89
Compressor Nameplate . . . . .	3	Propeller Exhaust Fan Option . . . . .	92
Gas Burner Nameplate . . . . .	3	Ultraviolet Lights Option . . . . .	95
Hazard Identification Information . . . . .	3	MicroTech Remote User Interface . . . . .	97
Unit Description . . . . .	4	VFD Compressor Operation . . . . .	99
Refrigeration Piping . . . . .	6	Variable Speed Scroll Compressor . . . . .	104
Control Locations . . . . .	7	Economizer Start-up . . . . .	108
Control Panel . . . . .	8	Compressor Startup . . . . .	109
Controls, Settings and Functions . . . . .	15	Heating System Startup . . . . .	111
FanTrol . . . . .	16	Air Balancing . . . . .	111
Condenser Fan Arrangement . . . . .	18	Drive Belt Alignments . . . . .	112
Unit Clearances . . . . .	19	Using the Keypad/Display . . . . .	117
Receiving Inspection . . . . .	19	Servicing Control Panel Components . . . . .	119
Roof Curb Assembly and Installation . . . . .	21	Planned Maintenance . . . . .	119
Post and Rail Mounting . . . . .	24	Unit Storage . . . . .	120
Lifting Guidance . . . . .	24	Scroll Compressor Piping . . . . .	126
Transit and Temporary Storage . . . . .	26	Refrigerant Charge . . . . .	128
Charging the System . . . . .	34	Control Panel Components . . . . .	131
Unit Piping . . . . .	36		
Damper Assemblies . . . . .	38		
HEPA Holding Frame, Filter, and Prefilter Installation 40			
Cabinet Weather Protection . . . . .	44		
Installing Ductwork . . . . .	44		
Field Power Wiring . . . . .	47		
Preparing Unit for Operation . . . . .	51		
Control Actuators . . . . .	78		
Modulating Hot Gas Reheat . . . . .	80		
Smoke and Fire Protection . . . . .	83		
Field Output Signals . . . . .	85		

This manual provides general information about the “D” vintage Daikin Applied RoofPak applied rooftop unit, models RPS, RDT, RFS and RCS. In addition to an overall description of the unit, it includes mechanical and electrical installation procedures, commissioning procedures, sequence of operation information, and maintenance instructions. For further information on the optional forced draft gas-fired furnace, refer to [IM 684](#) or [IM 685](#).

The MicroTech applied rooftop unit controller is available on “D” vintage applied rooftop units. For a detailed description of the MicroTech components, input/output configurations, field wiring and information on using and programming the MicroTech unit controller, refer to [OM 920](#).

For a description of operation and information on using the keypad to view data and set parameters, refer to the appropriate program-specific operation manual (see [Figure 1](#)).

**Table 1: Program Specific Rooftop Unit Literature**

	Rooftop unit control configuration	Operation manual number
VFDs	Daikin Applied 208 -460 V	OM 844
	Daikin Applied 575 V	OM 895
	Non-Daikin Applied	See vendor manuals

## Unit Nameplate

The unit nameplate is located on the outside lower right corner on the main control box door. It includes the unit model number, serial number, unit part number, electrical characteristics, and refrigerant charge.

## Compressor Nameplate

On units that utilize the tandem compressor design, each compressor includes an individual nameplate along with a nameplate identifying the tandem compressors.

On units that utilize the trio compressor design, each compressor includes an individual nameplate. There is no nameplate identifying the trio compressors.

## Gas Burner Nameplate

On units that include gas heat, the nameplate is located on the lower right corner on the main control box door. It includes the burner model number, minimum/maximum input, maximum temperature rise, and minimum CFM.

## Hazard Identification Information

**⚠ DANGER**  
Dangers indicate a hazardous situation which will result in death or serious injury if not avoided.

**⚠ WARNING**  
Warnings indicate potentially hazardous situations, which can result in property damage, severe personal injury, or death if not avoided.

**⚠ CAUTION**  
Cautions indicate potentially hazardous situations, which can result in personal injury or equipment damage if not avoided.

**Figure 1: Nomenclature**

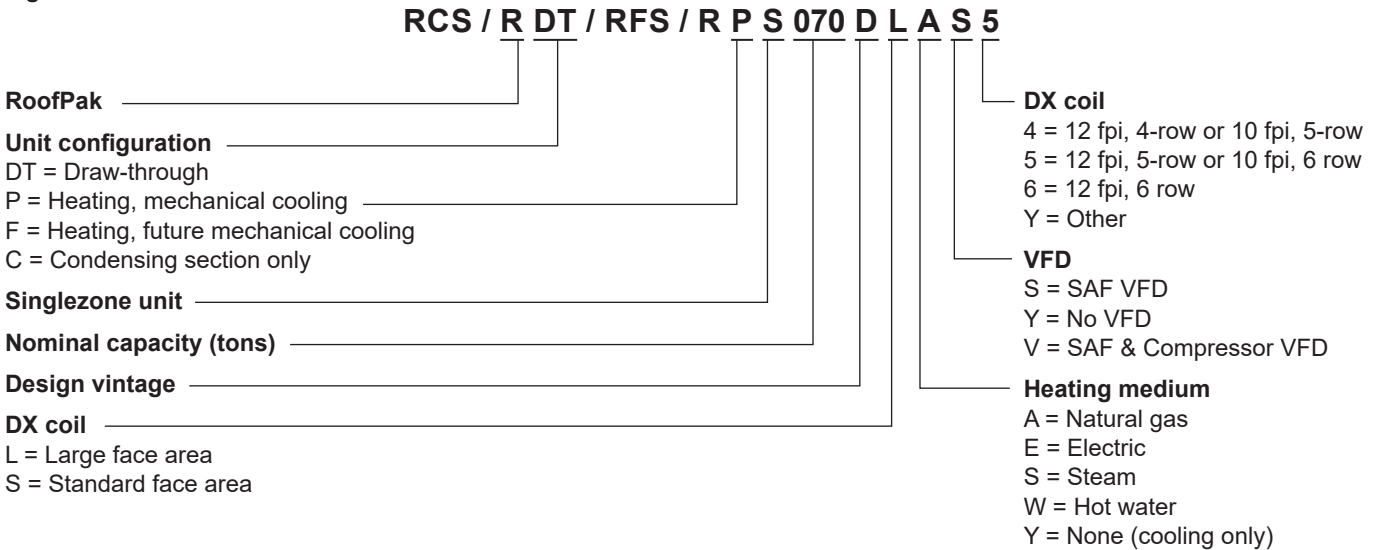

## Unit Description

### Typical Component Locations

Figure 2 shows an RPS/RDT/RFS/RCS unit. Figure 3 shows a typical RPS unit with the locations of the major components. Figure 4 shows a typical RDT unit with the locations of the major components. These figures are for general information only. See the project's certified submittals for actual specific dimensions and locations.

Figure 2: RPS/RDT/RFS/RCS Unit

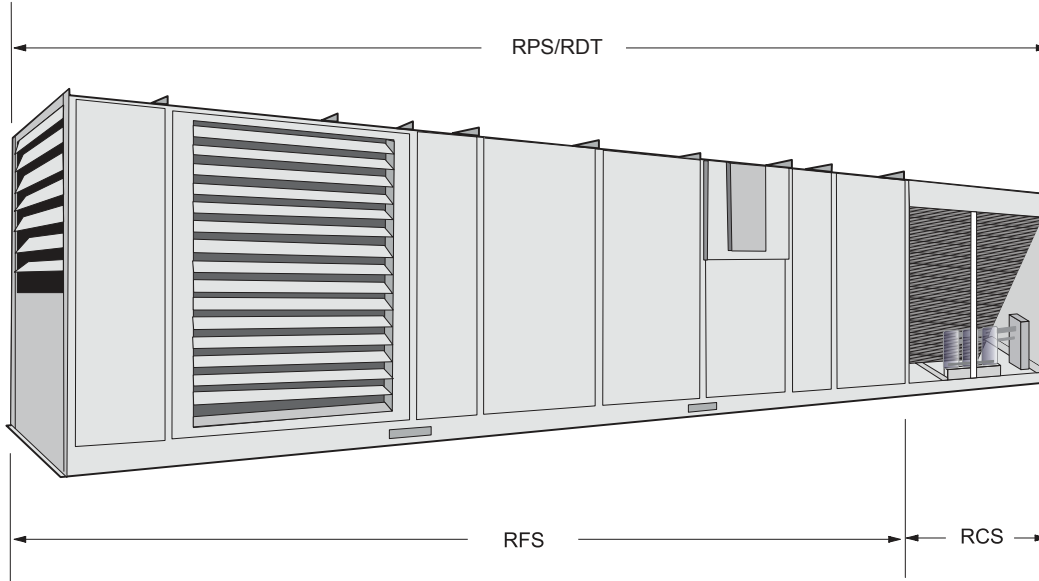
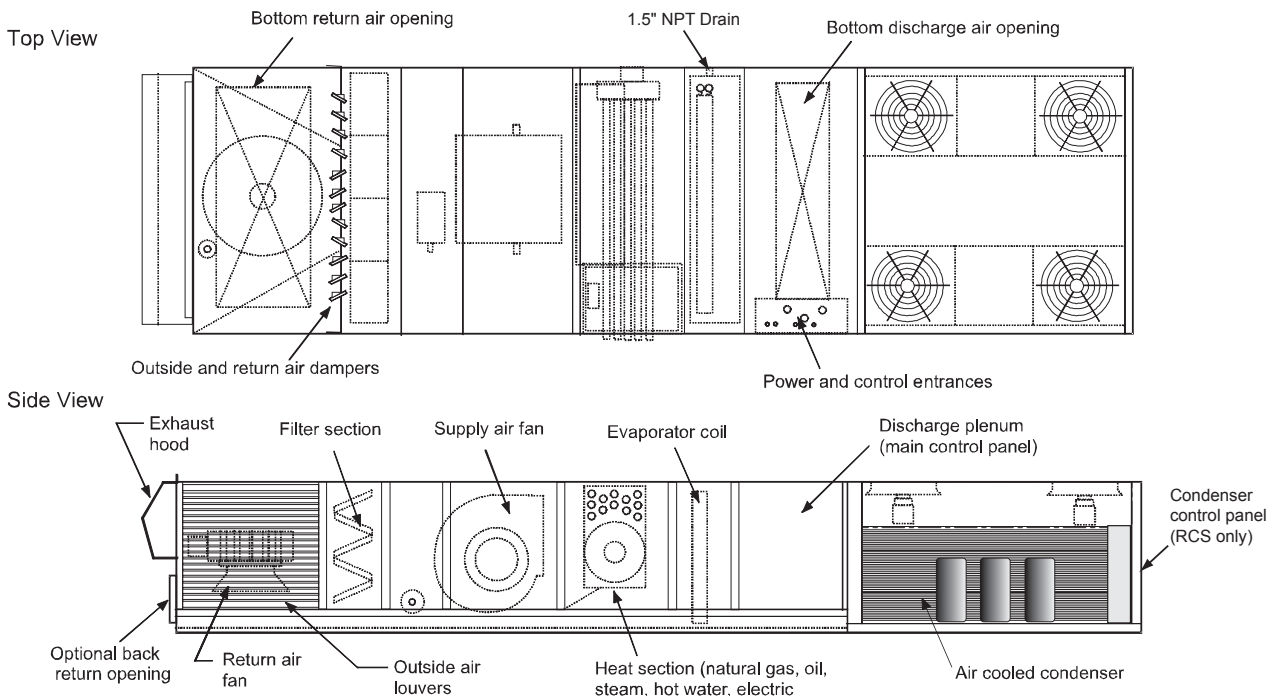
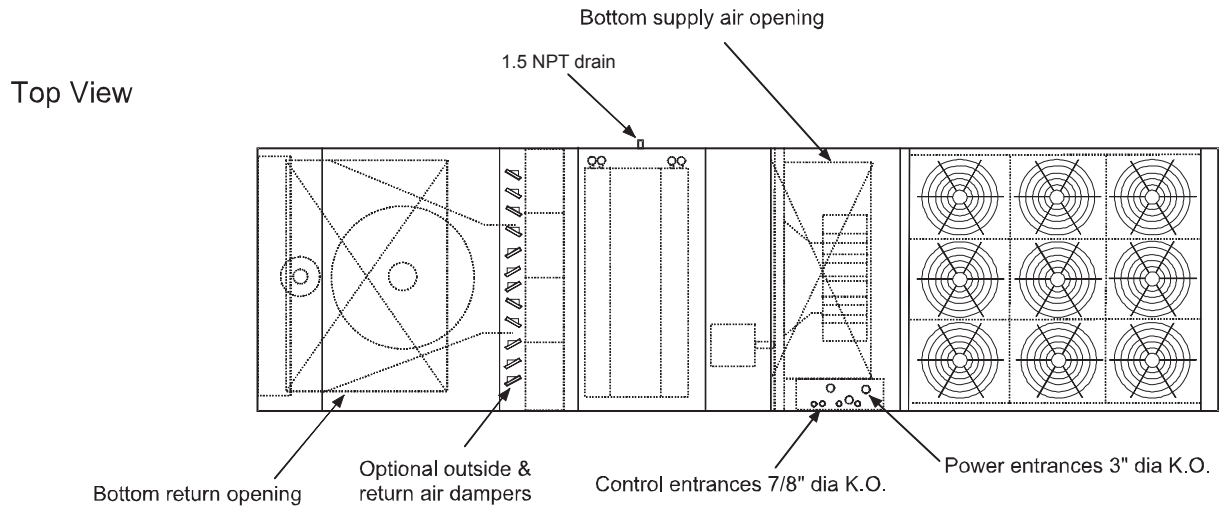

Figure 3: Typical Component Locations—RPS Units



**Figure 4: Component Locations—RDT Units**



Side View

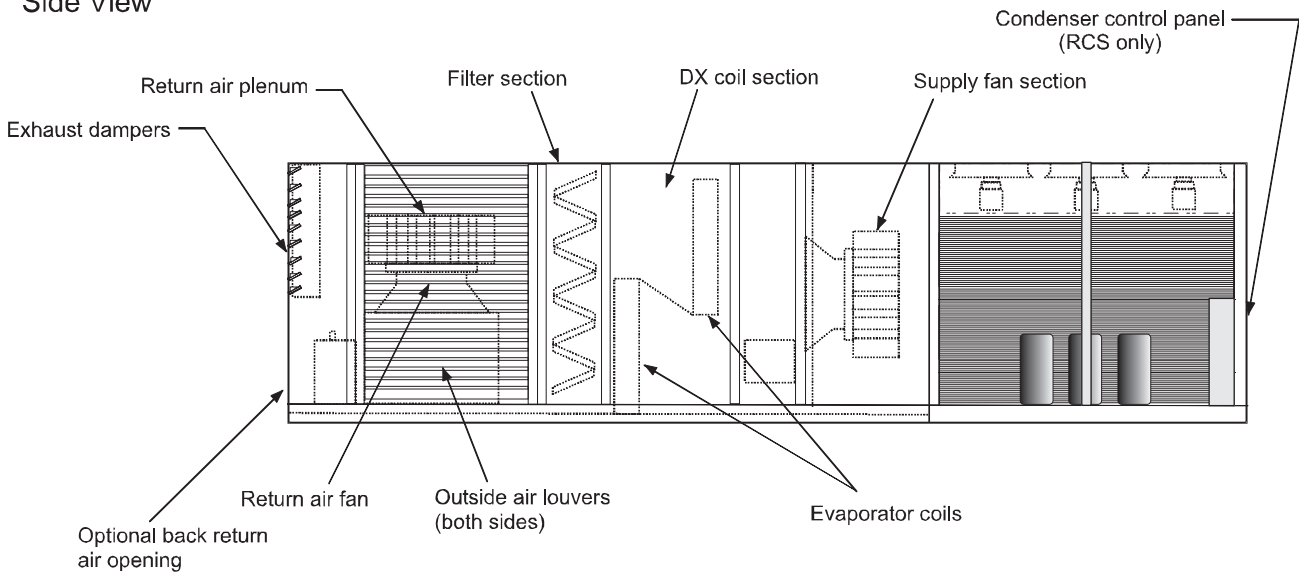

# Refrigeration Piping

This section presents the unit refrigeration piping diagrams for the various available configurations.

Figure 5: Circuit Schematic

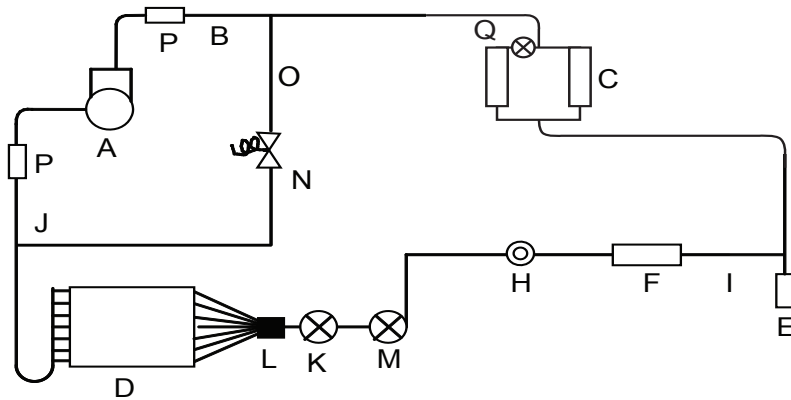

- A Compressor (1, 2, or 3 per circuit) †
- B Discharge line †
- C Condenser coil †
- D Evaporator coil \*
- E Manual charging/evacuation valve †
- F Filter-drier †
- H Sightglass †
- I Liquid line \*†
- J Suction line \*†
- K Thermal expansion valve \*
- L Distributor \*
- M Drop solenoid valve \*
- N Hot gas bypass valves (optional) \*
- O Hot Gas bypass piping (optional) \*†
- P Manual shutoff valve (optional)
- Q Condenser Coil Splitter Solenoid Valve\*\*

\*Supplied on RFS units

\*\*Variable Speed Inverter Compressor Unit Only

†Supplied on RCS units

Figure 6: Condenser Piping, Scroll Compressors, 2 to 3 Compressors per Circuit are Provided (6 Compressors\* Shown)

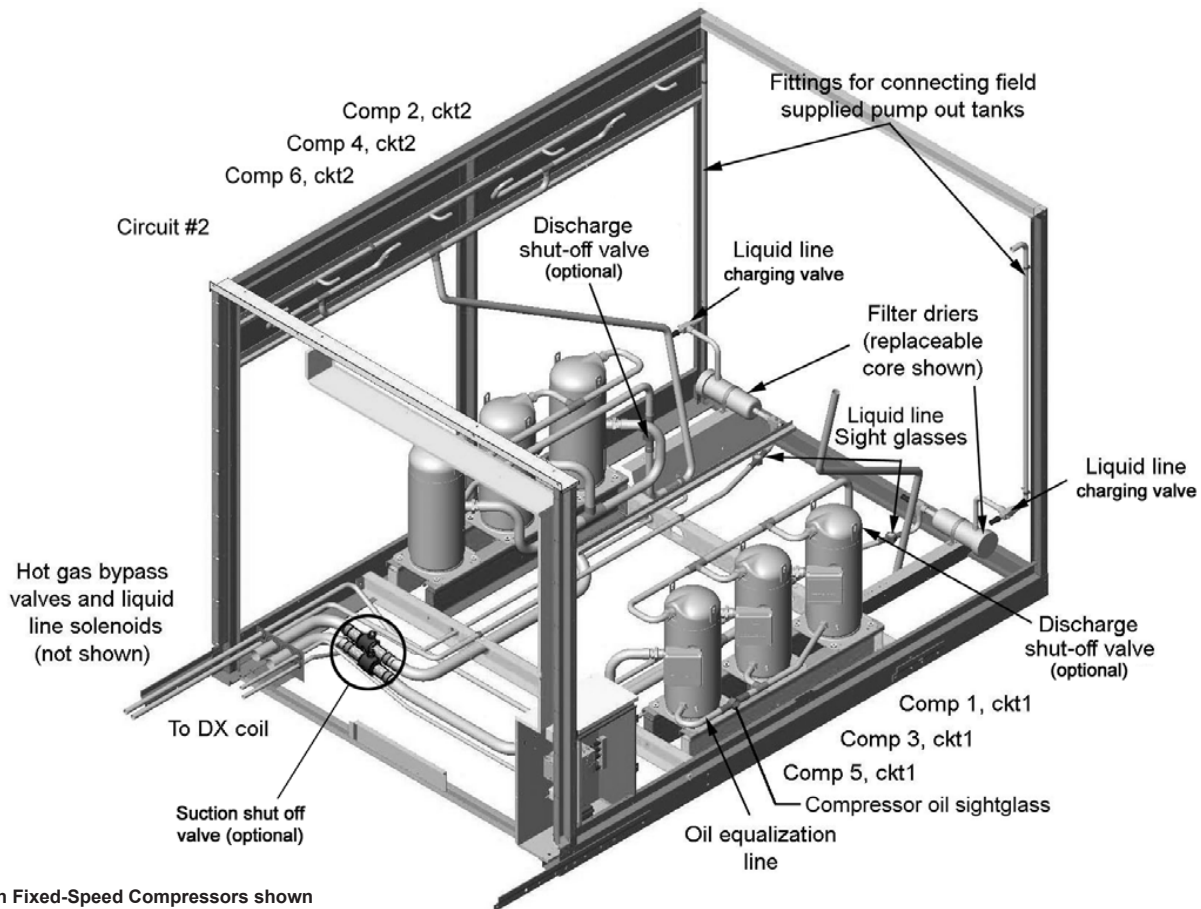

# Control Locations

Figure 7 (RPS Units) and Figure 8 (RDT Units) Additional information is included in Table 2 on page 15 and show the locations of the various control components mounted the wiring diagram legend, which is included in wiring throughout the unit.

See Control Panel on page 8 for the Wiring Diagrams on page 56 locations of control components mounted in control panels.

Figure 7: Control Locations—RPS units

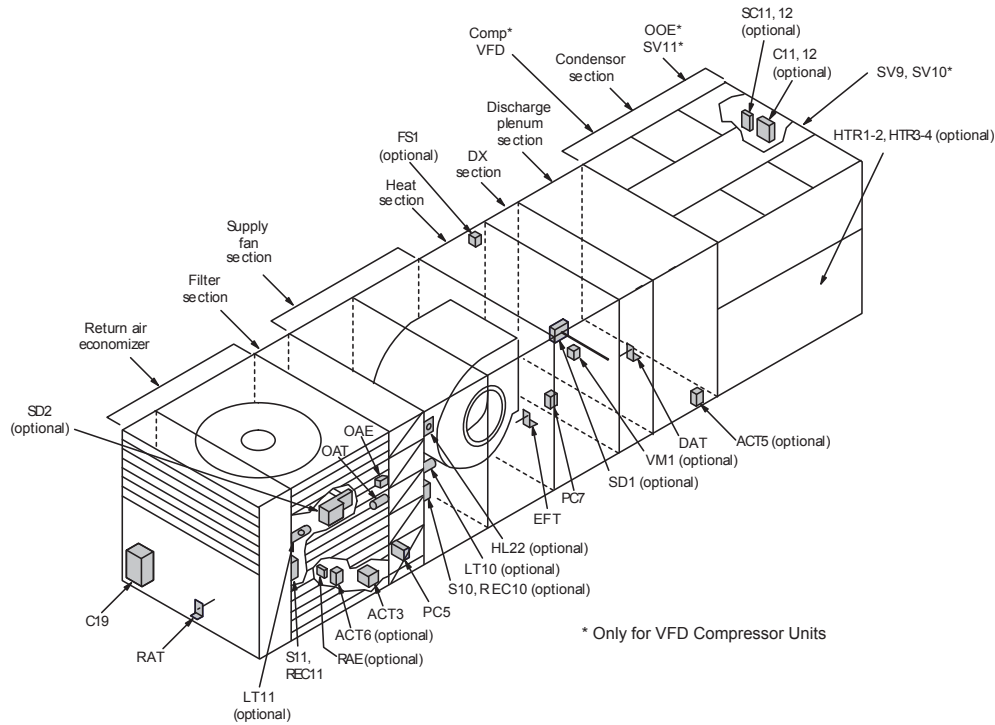
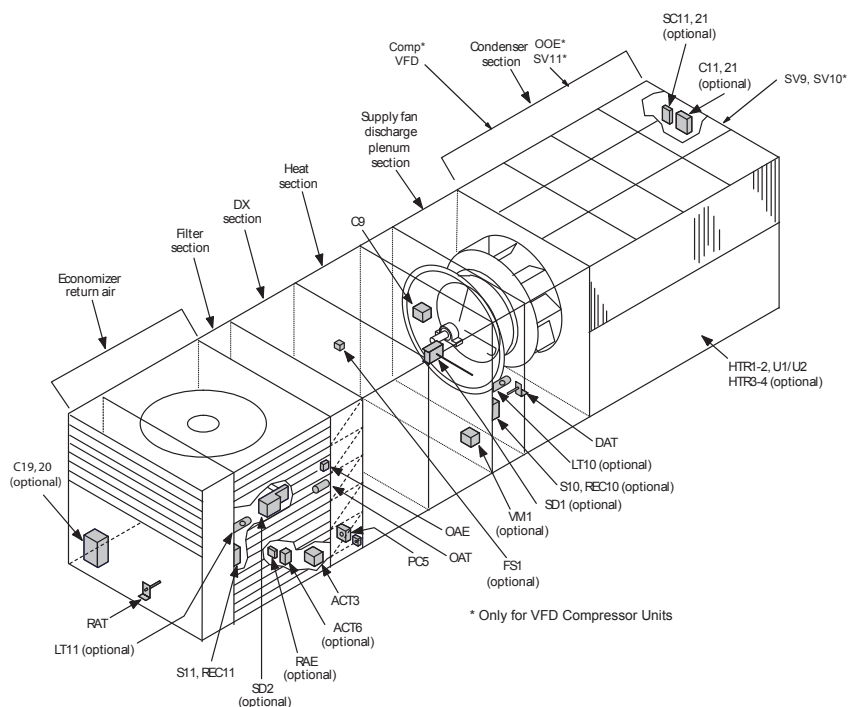

Figure 8: Control Locations—RDT Units



# Control Panel

The unit control panels and their locations are shown in these figures depending on the particular unit options. See [Wiring Diagrams on page 56](#) for the legend and configuration. Specific unit configurations may differ slightly from component description.

**Figure 9: Control Panel Locations**

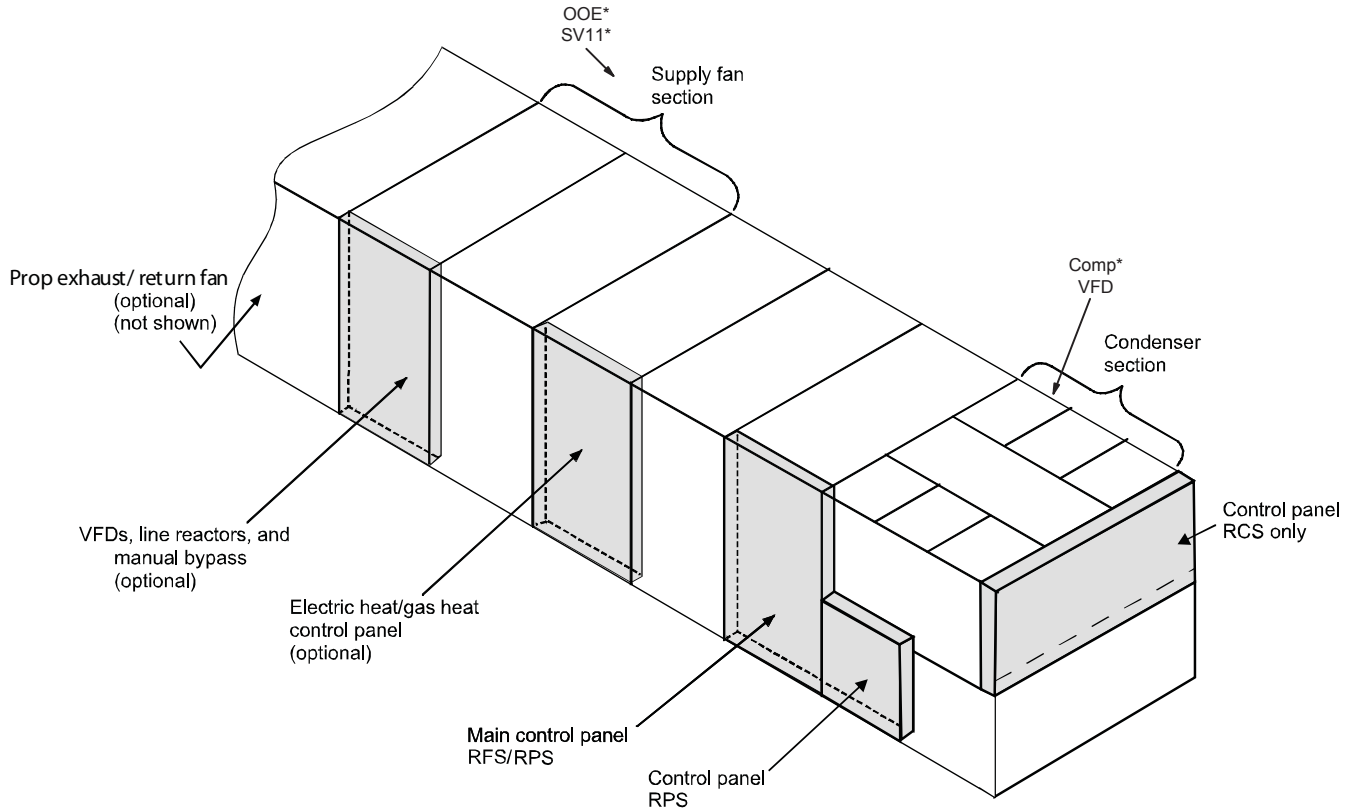

\* Located on the opposite side of the RPS Condensing Unit Control Panel



Figure 10: Typical Main Control Panel, 045D to 075D, 460 Volt

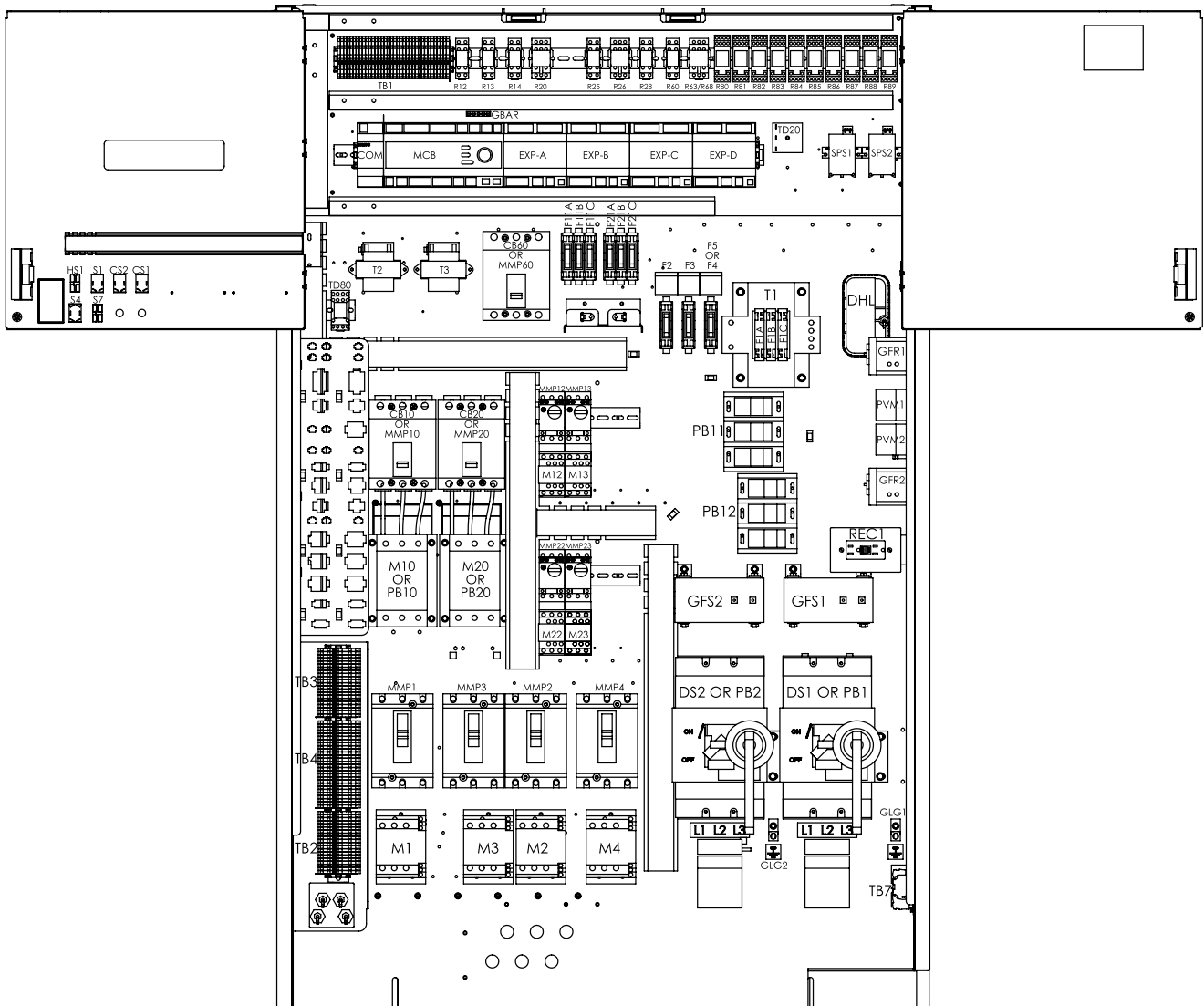
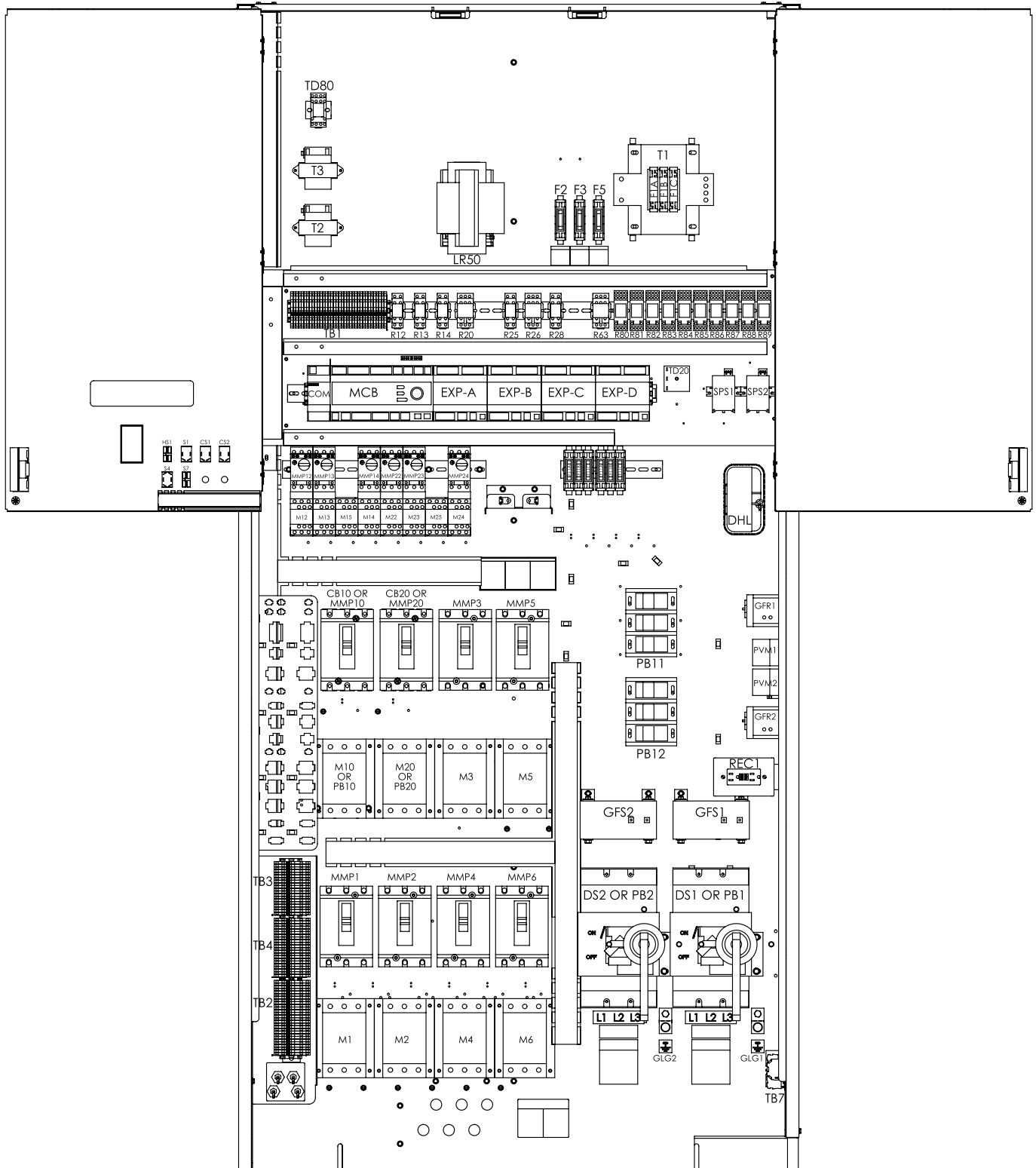
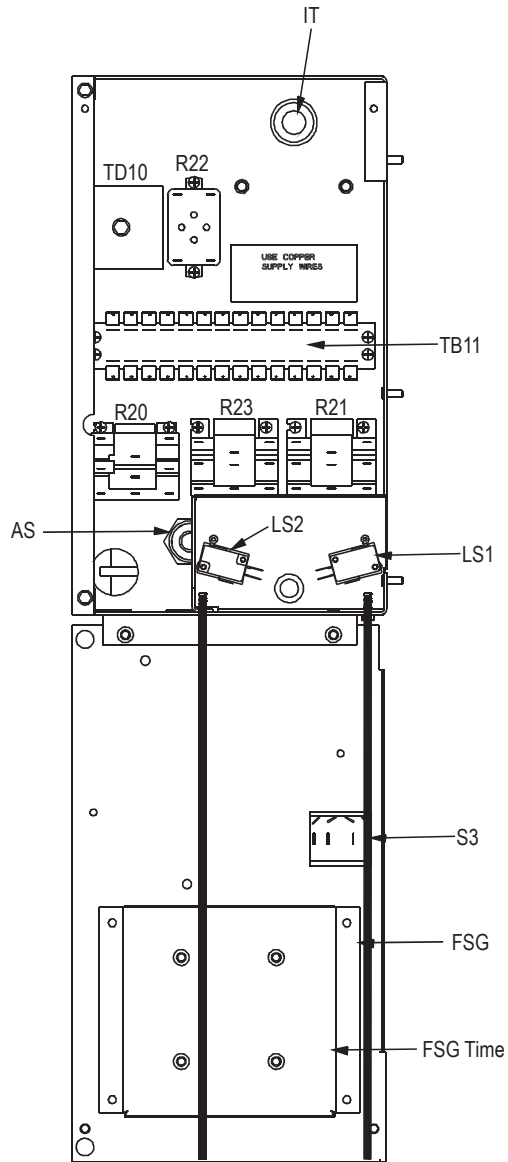

Figure 11: Typical Main Control Panel, 080D to 140D, 460 Volt



**Figure 12: Typical Gas Heat Panel, 1000 MBh (High TD)**



**Figure 13: Typical Prop Exhaust Panel, 3 Fans, 460 Volt**

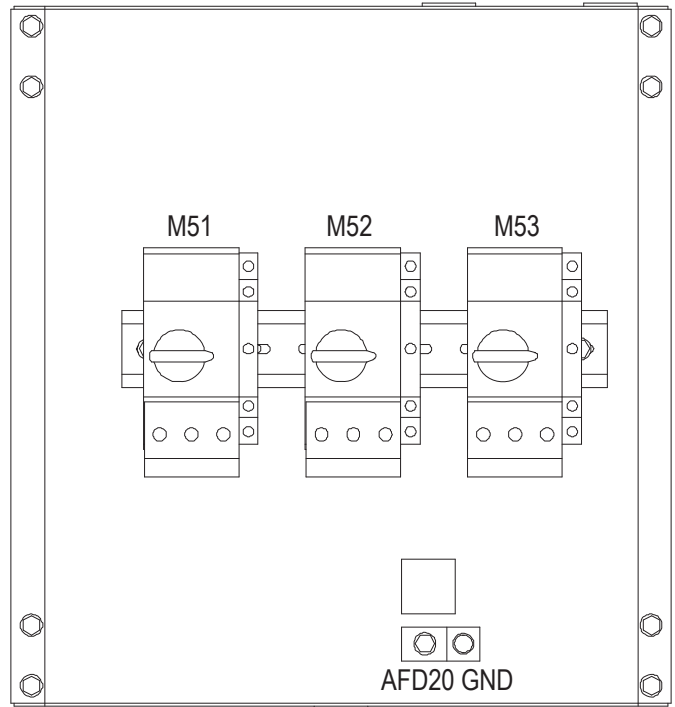

**Figure 14: VFD Bypass Panel, 40 HP, 460 Volt**

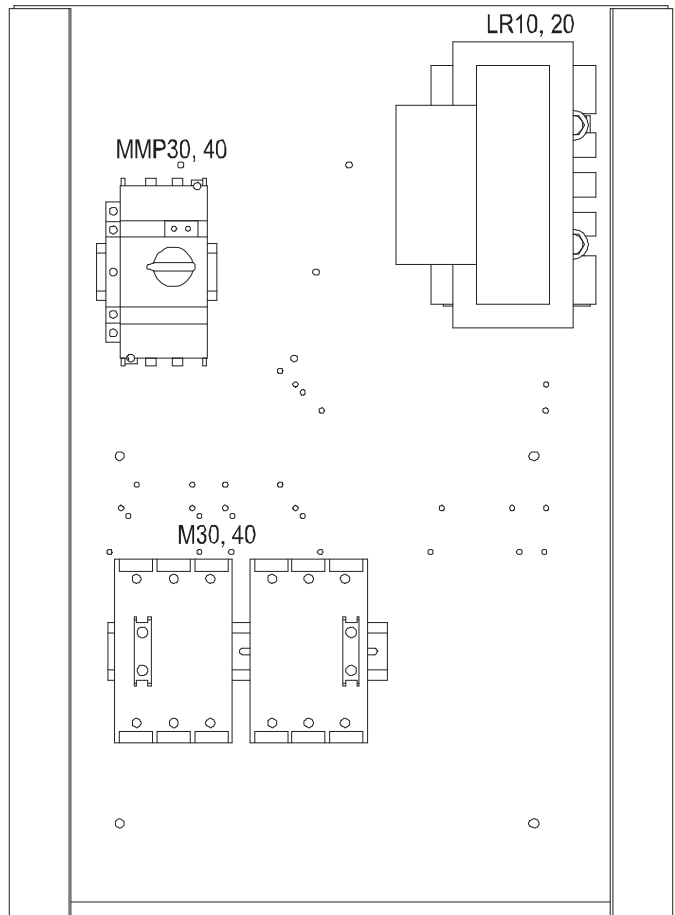

**Figure 15: RCS Control Panel with MicroTech, RPS 045D to 079D**

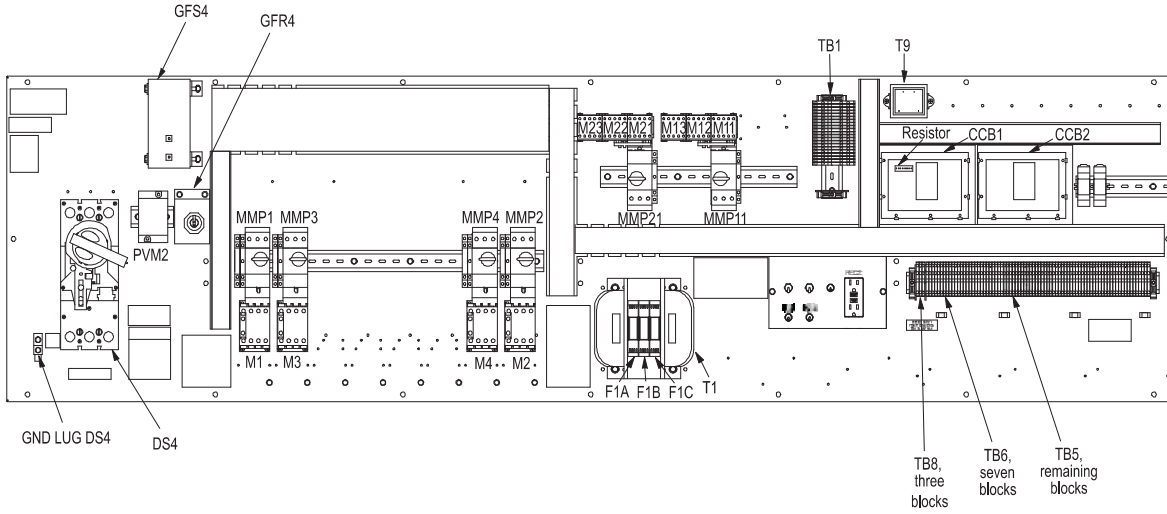

**Figure 16: RCS Control Panel with MicroTech, RPS 080D to 140D**

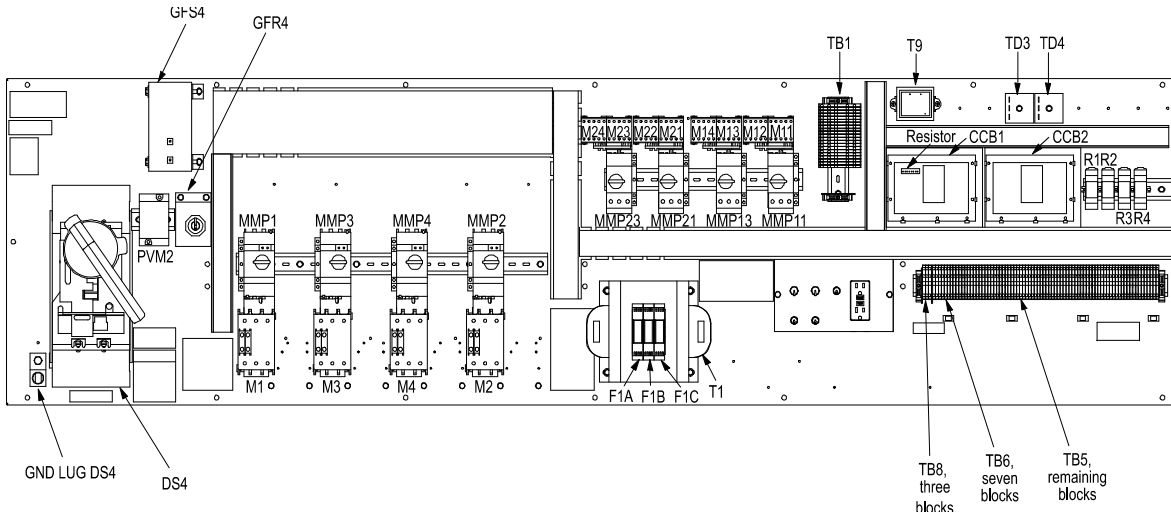

**Figure 17: Electric Heat Panel, Sizes 045D to 79D**

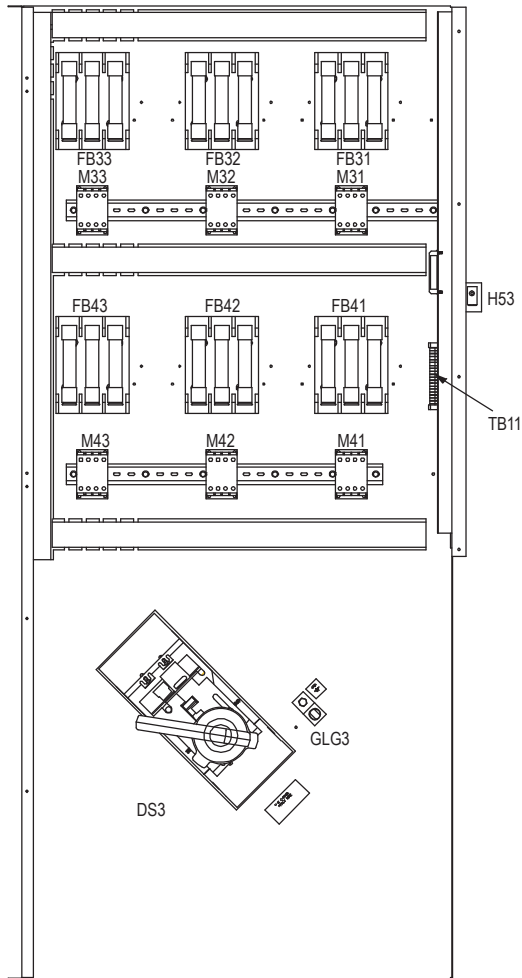

**Figure 19: Electric Heat Panel, Sizes 080D to 140D**

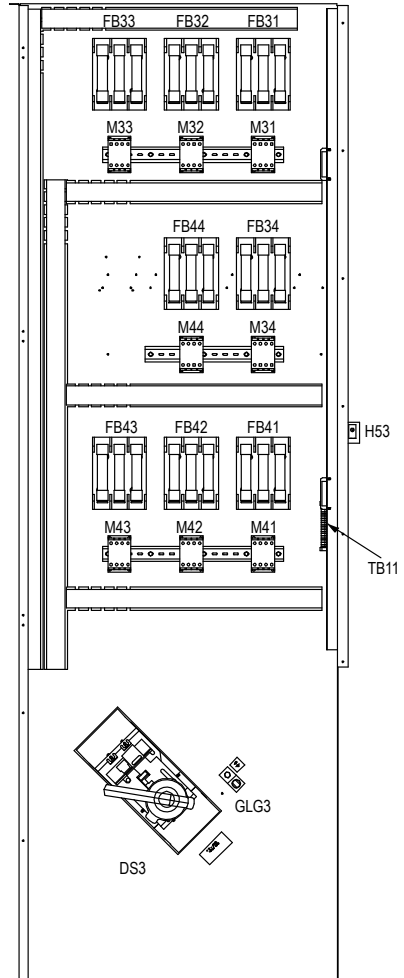

**Figure 18: VFD Compressor Panel, Sizes 016D–074D**

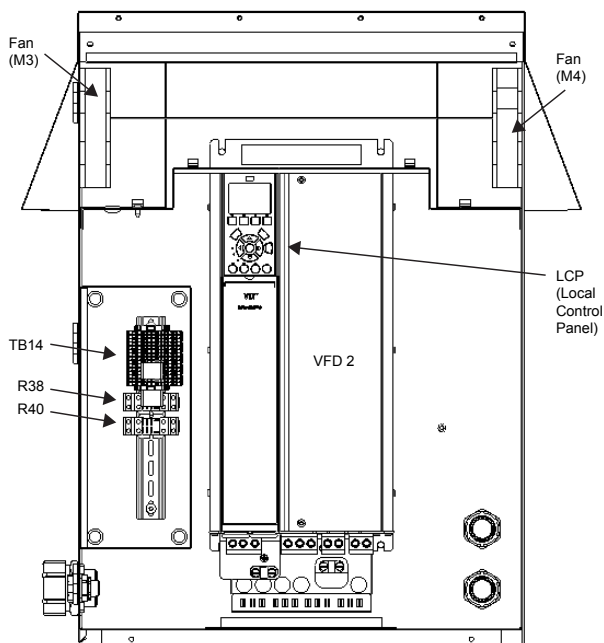

**Figure 20: Harness Plug Connector Detail**

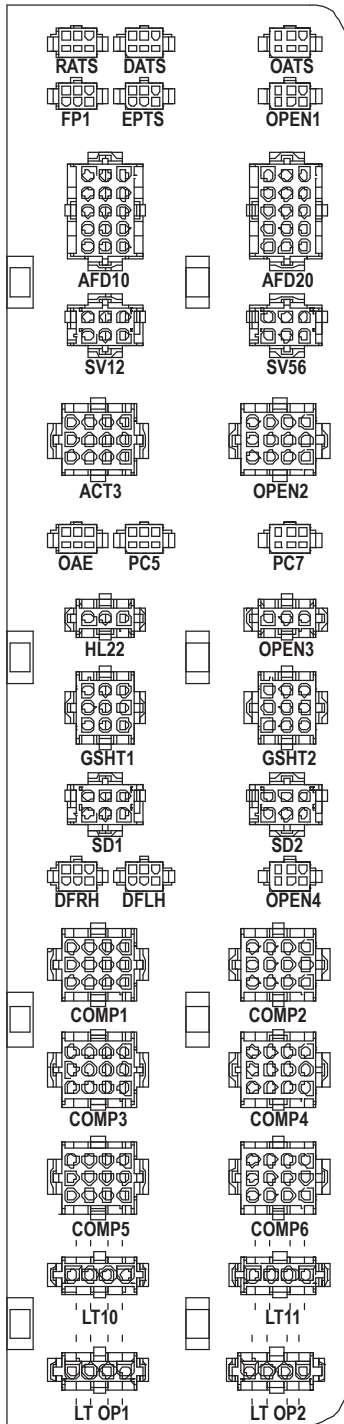

# Controls, Settings and Functions

**Table 2: Controls, Settings, and Functions**

Symbol	Description	Function	Reset	Location	Setting	Range	Differential	Part No.
CS1 & 2	Switch (toggle), refrigerant circuit	Shuts off compressor control circuits manually	N/A	Main control panel	N/A	N/A	N/A	01355000
CDS 2	Discharge Thermostat	Refrigerant temperature	N/A	Compressor	N/A	N/A	N/A	910150290
DAT	Discharge air temperature sensor	Senses discharge air temperature	N/A	Discharge air section	N/A	N/A	N/A	060004705
DHL	Duct high limit switch	Prevents excessive VAV duct pressures; shuts fan OFF	Auto	Main control panel	3.5" w.c. (871.8 Pa)	0.05–5.0" w.c. (12.5–1245.4 Pa)	0.05" w.c. (12.5 Pa), fixed	065493801
EFT	Entering fan air temperature sensor	Senses entering fan air temperature	N/A	Inlet of supply fan	N/A	N/A	N/A	060004705
FP1, 2	Frost protection	Senses DX coil temperature for frost protection	Auto	DX coil	30° +/-6° open 45° +/- 6° close	N/A	15°	113073401
FS1	Freezestat	Shuts fans OFF, opens heating valve, and closes outdoor damper if low air temperature at coil is detected	Auto	Heating section	38°F (3°C) or as required	35°F–45°F (2°C–7°C)	12°F (7°C), fixed	065830001
HP1, 2	High pressure control	Stops compressor when refrigerant discharge pressure is too high	Manual (relay latched)	Condenser panel	See page 115	N/A	150 psi	403585001
LP1, 2	Low pressure control	Stops compressor when suction pressure is too low	Auto	Condenser panel	See page 115	N/A	50 psi low ambient option/ 70 psi standard	910139364
MCB	Main control board	Processes input information	N/A	Main control box	N/A	N/A	N/A	060006101
MF3, 4	Cooling fan	Ventilate VFD box	N/A	VFD box	N/A	N/A	N/A	910147046
MP1–6	Compressor motor protector	Senses motor winding temperature, shuts compressor OFF on high temperature	Auto at 3400 ohms	Compressor junction box	9 K–18 K ohms	700 ohms cold	N/A	044691509
OAE	Enthalpy control (electromechanical)	Returns outside air dampers to minimum position when enthalpy is too high	Auto	Economizer section	"B" or as required	A–D	Temperature: 3.5°F (2°C) Humidity: 5% fixed	030706702
	Enthalpy control (electronic)	Returns outside air dampers to minimum position when outside air enthalpy is higher than return air enthalpy (use RAE)	Auto	Economizer section Fully CW past "D" (when used with RAE)	A–D	N/A	N/A	049262201
OAT	Outside air temperature sensor	Senses outside air temperature	N/A	N/A	N/A	N/A	N/A	060004705
OOS	Optical Oil Sensor	Sense oil level	N/A	Compressor sump	N/A	N/A	N/A	910150291
PC5	Dirty filter switch	Senses filter pressure drop	Auto	First filter section	As required	0.05–5" w.c. (12.5–1245.4 Pa)	0.05" w.c. (12.5 Pa)	065493801
PC6	Dirty filter switch	Senses filter pressure drop	Auto	Final filter section	As required	0.05–5" w.c. (12.5–1245.4 Pa)	0.05" w.c. (12.5 Pa)	065493801
PC7	Airflow proving switch	Senses supply fan pressure to prove airflow	Auto	Supply fan section	0.10" w.c. (25 Pa)	0.05–5" w.c. (12.5–1245.4 Pa)	0.05" w.c. (12.5 Pa), fixed	060015801
PT1, 2	Pressure transducer	Sense high side pressure	N/A	Condenser panel	N/A	0–700 psig	N/A	910153045
RAE	Return air enthalpy sensor	Used to compare return air enthalpy to outside air enthalpy (used with OAE)	N/A	Economizer section	N/A	N/A	N/A	049262202
RAT	Return air temperature sensor	Senses return air temperature	N/A	Return air section	N/A	N/A	N/A	060004705
SD1	Smoke detector, supply air	Initiates unit shutdown if smoke is detected	Manual	Discharge air section	N/A	N/A	N/A	04925001
SD2	Smoke detector, return air	Initiates unit shutdown if smoke is detected	Manual	Return air section	N/A	N/A	N/A	04925001
SPS1	Static pressure sensor duct #1	Converts static pressure signals to voltage signals	N/A	Main control box	N/A	0–5" w.c. (0–1245.4 Pa) 1–6 V (dc) out	N/A	049545007
SPS2	Static pressure sensor duct #2	Converts static pressure signals to voltage signals	N/A	Main control box	N/A	0–5" w.c. (0–1245.4 Pa) 1–6 V (dc) out	N/A	049545007
	Static pressure sensor: building (space) pressure	Converts static pressure signals to voltage signals	N/A	Main control box	N/A	-025–0.25" w.c. (-62.3–62.3 Pa) 1–5 V (dc) out	N/A	049545006
S1	System switch	Shuts off entire control circuit (except crankcase heaters)	N/A	Main control box	N/A	N/A	N/A	001355000
S7	ON-OFF-AUTO switch	Used to manually switch unit	N/A	Main control box	N/A	N/A	N/A	—
SV1-2	Drop solenoid	Shuts liquid line when compressor is OFF	N/A	Discharge air section	N/A	N/A	N/A	049266502
SV9, 10	Splitter solenoid valve	Control refrigerant flow	N/A	Condenser	Normally open	Open at 350 psig Close at 250 psig	N/A	—
SV11	OIV injection solenoid	Direct oil in compressor	N/A	Compressor	Normally closed	N/A	Activated above 50 rps	910150289

## FanTrol

The FanTrol, provided on all units, is a method of head pressure control that automatically cycles the condenser fans in response to ambient air temperature. This feature maintains head pressure and allows the unit to run at low ambient air temperatures.

RPS/RDT and RCS units have two independent refrigerant circuits with one to four condenser fans being controlled independently by the ambient air temperature of each circuit. See the following sections for sequence of operation for condenser fans with FanTrol.

FanTrol does not apply to units with VFD compressors.

**Table 3: R-410A FanTrol Set points in °F with MicroTech Controls.**

Unit Size	Degrees Fahrenheit					
	D07a		D08b		PC13/PC23c	
	Set point	Differential	Set point	Differential	Set point	Differential
015	70	5				
016	75	5				
020	70	5				
021	75	5				
025	60	5				
026	70	5				
030	75	5				
031	75	5				
035	70	5				
040	65	5				
042	65	5				
045	65	5				
050	65	5				
051	70	5				
061	60	5				
063	70	5				
068	70	5				
070	75	5			90	35
071	75	5			90	35
075	65	5	85	5	90	35
079	65	5	80	5	90	35
080	75	5			90	35
081	75	5			90	35
085	70	5			90	35
090	60	5	85	5	90	35
091	60	5	85	5	90	35
100	60	5	85	5	90	35
101	60	5	85	5	90	35
105	50	5	80	5	90	35
110	65	5	90	5	90	35
120	65	5	85	5	90	35
125	65	5	85	5	90	35
130	60	5	85	5	90	35
140	55	5	80	5	90	35

- a. D07 = TC12
- b. D08 = TC14
- c. PC13/23 Cut in = 450 psig (125 degree sat.), fixed  
Cut out = 275 psig (90 degree sat.), fixed



**Table 4: R-410A Fan Cycling Set points in °F with No Controls**

RPS, RCS, RDT, RPR	Control ID	Degrees °F			Notes
		Cut Out	Cut In	Differential	
015	TC12	65	70	5	TC12 Controls 1 Fan
016	TC12	70	75	5	TC12 Controls 1 Fan
020	TC12	65	70	5	TC12 Controls 1 Fan
021	TC12	70	75	5	TC12 Controls 1 Fan
025	TC12	55	60	5	TC12 Controls 1 Fan
026	TC12	65	70	5	TC12 Controls 1 Fan
030	TC12	70	75	5	TC12 Controls 1 Fan
031	TC12	70	75	5	TC12 Controls 1 Fan
035	TC12	65	70	5	TC12 Controls 1 Fan
040	TC12	60	65	5	TC12 Controls 1 Fan
042	TC12	60	65	5	TC12 Controls 1 Fan
045	TC12	60	65	5	TC12 Controls 1 Fan
050	TC12	60	65	5	TC12 Controls 1 Fan
051	TC12	65	70	5	TC12 Controls 1 Fan
061	TC12	55	60	5	TC12 Controls 1 Fan
063	TC12	65	70	5	TC12 Controls 1 Fan
068	TC12	65	70	5	TC12 Controls 1 Fan
070	TC12	65	70	5	TC12 Controls 1 Fan
	PC13/PC23	90	125	35	PC13/PC23 Controls 1 Fan*
071	TC12	65	70	5	TC12 Controls 1 Fan
	PC13/PC23	90	125	35	PC13/PC23 Controls 1 Fan*
075	TC12	60	65	5	TC12 Controls 1 Fan
	TC14	80	85	5	TC14 Controls 1 Fan
	PC13/PC23	90	125	35	PC13/PC23 Controls 1 Fan*
079	TC12	65	65	5	TC12 Controls 1 Fan
	TC14	75	80	5	TC14 Controls 1 Fan
	PC13/PC23	90	125	35	PC13/PC23 Controls 1 Fan*
080	TC12	70	75	5	TC12 Controls 1 Fan
	PC13/PC23	90	125	35	PC13/PC23 Controls 1 Fan*
081	TC12	70	75	5	TC12 Controls 1 Fan
	PC13/PC23	90	12	35	PC13/PC23 Controls 1 Fan*
085	TC12	65	70	5	TC12 Controls 1 Fan
	PC13/PC23	90	125	35	PC13/PC23 Controls 1 Fan*
090	TC12	55	60	5	TC12 Controls 1 Fan
	TC14	80	85	5	TC14 Controls 1 Fan
	PC13/PC23	90	125	35	PC13/PC23 Controls 1 Fan*
091	TC12	55	60	5	TC12 Controls 1 Fan
	TC14	80	85	5	TC14 Controls 1 Fan
	PC13/PC23	90	125	35	PC13/PC23 Controls 1 Fan*
100	TC12	55	60	5	TC12 Controls 1 Fan
	TC14	80	85	5	TC14 Controls 1 Fan
	PC13/PC23	90	125	35	PC13/PC23 Controls 1 Fan*
101	TC12	55	60	5	TC12 Controls 1 Fan
	TC14	80	85	5	TC14 Controls 1 Fan
	PC13/PC23	90	125	3	PC13/PC23 Controls 1 Fan*
105	TC12	45	50	5	TC12 Controls 1 Fan
	TC14	75	80	5	TC14 Controls 1 Fan
	PC13/PC23	90	125	35	PC13/PC23 Controls 1 Fan*
110	TC12	60	65	5	TC12 Controls 1 Fan
	TC14	85	90	5	TC14 Controls 1 Fan
	PC13/PC23	90	125	35	PC13/PC23 Controls 1 Fan*
120	TC12	60	65	5	TC12 Controls 1 Fan
	TC14	80	85	5	TC14 Controls 1 Fans
	PC13/PC23	90	125	35	PC13/PC23 Controls 1 Fan*
125	TC12	60	65	5	TC12 Controls 1 Fan
	TC14	80	85	5	TC14 Controls 1 Fan
	PC13/PC23	90	125	35	PC13/PC23 Controls 1 Fan*
130	TC12	55	60	5	TC12 Controls 1 Fan
	TC14	80	85	5	TC14 Controls 1 Fan
	PC13/PC23	90	125	35	PC13/PC23 Controls 1 Fan*
140	TC12	50	55	5	TC12 Controls 1 Fan
	TC14	75	80	5	TC14 Controls 2 Fans
	PC13/PC23	90	125	35	PC13/PC23 Controls 1 Fan*

\* PC13/23Cut in = 450 psig (125 degree sat.), Fixedcut out = 275 psig (90 degree sat.), Fixed

# Condenser Fan Arrangement

Table 5 shows the condenser fan numbering conventions and locations for each unit size.

**Table 5: Condenser Fan Arrangement**

Unit size	Refrigerant circuit	Arrangement	Unit size	Refrigerant circuit	Arrangement
015, 016, 025, 026, 020, 021	1 2		074	1 2	
030, 031, 035, 042	1 2		075, 079, 090, 091	1 2	
045	1 2		100, 101	1 2	
050, 051	1 2		110	1 2	
061, 063, 068	1 2		120	1 2	
070, 071, 080, 081	1 2		125	1 2	
			130, 140	1 2	

The installation of this equipment shall be in accordance with the regulations of authorities having jurisdiction and all applicable codes. It is the responsibility of the installer to determine and follow the applicable codes.

**NOTE:** Low head pressure may lead to poor, erratic refrigerant feed control at the thermostatic expansion valve. The units have automatic control of the condenser fans which should provide adequate head pressure control down to 50°F (10°C) provided the unit is not exposed to windy conditions. The system designer is responsible for assuring the condensing section is not exposed to excessive wind or air recirculation.

**CAUTION**

Sharp edges on sheet metal and fasteners can cause personal injury.

This equipment must be installed, operated, and serviced only by an experienced installation company and fully trained personnel.

## Unit Clearances

### Service Clearance

Allow service clearance approximately as indicated in [Figure 21](#). Also, Daikin Applied recommends providing a roof walkway to the rooftop unit as well as along at least the two sides of the unit that provide access to most controls and serviceable components.

**Figure 21: Service Clearances**

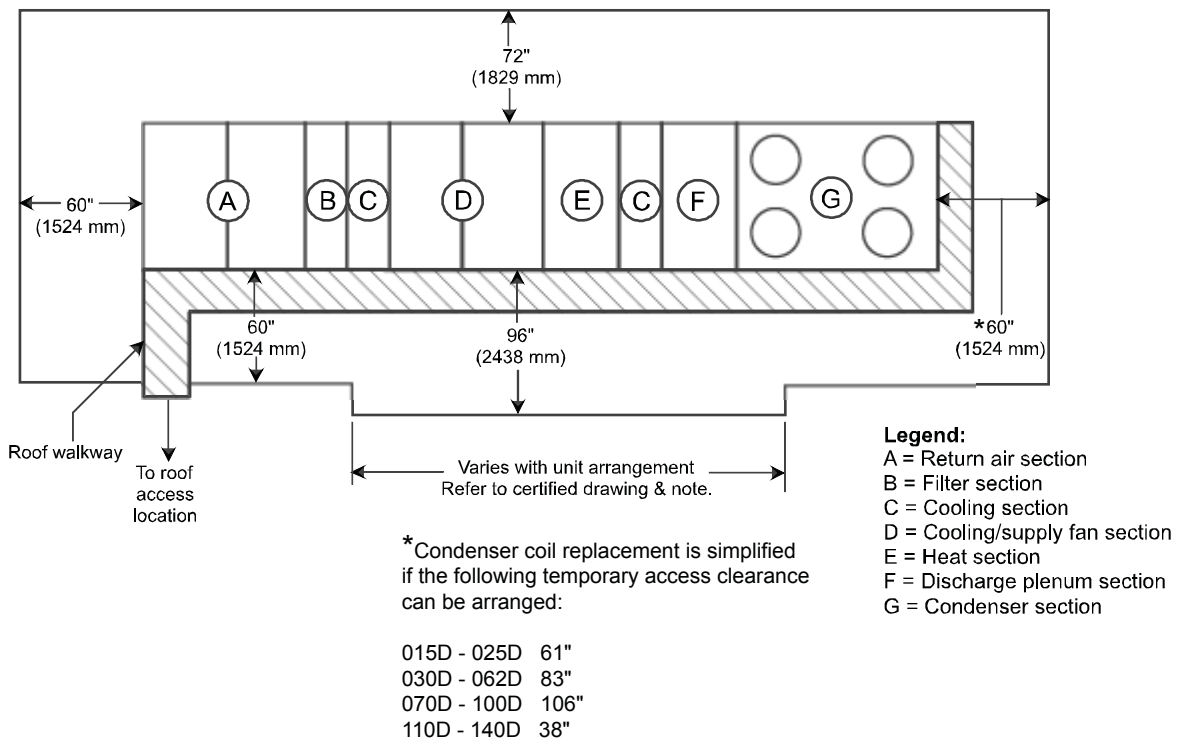

## Receiving Inspection

Carefully check equipment against the bill of lading to ensure all items have been received. Before unloading any unit, check the nameplate to make sure the voltage complies with the power supply available.

Inspect all units for damage upon arrival. If a unit has become dirty during shipment, carefully clean it prior to completing the inspection. Daikin Applied is not responsible for physical damage after the unit leaves the factory.

**NOTICE**

All units should be carefully inspected for damage when received. Report all loss or shipping damage using a claim form supplied by Daikin Applied.

**VISIBLE LOSS OR DAMAGE:** Any external evidence of loss or damage must be noted on the freight bill or carrier's receipt, and signed by the carrier's agent. Failure to adequately describe such external evidence of loss or damage may result in the carrier's refusal to honor a damage claim.

**CONCEALED LOSS OR DAMAGE:** Concealed loss or damage means loss or damage which does not become apparent until the unit has been unpacked or unwrapped. The contents may be damaged in transit due to rough handling even though the exterior may not show damages. When the damage is discovered, make a written request for inspection by the carrier's agent within **five (5) days** of the delivery date and file a claim with the form provided by Daikin Applied. Refer to the Daikin Applied Freight Policy for further information.

## Ventilation Clearance

Below are minimum ventilation clearance recommendations. The system designer must consider each application and provide adequate ventilation. If this is not done, the unit will not perform properly.

### Unit(s) surrounded by a screen or a fence:

1. The bottom of the screen or fence should be at least 1 ft. (305 mm) above the roof surface.
2. The distance between the unit and a screen or fence should be as described in [Service Clearance on page 19](#). See also [Figure 21](#).
3. The distance between any two units within a screen or fence should be at least 120" (3048 mm).

### Unit(s) surrounded by solid walls:

1. If there are walls on one or two adjacent sides of the unit, the walls may be any height. If there are walls on more than two adjacent sides of the unit, the walls should not be higher than the unit.
2. The distance between the unit and the wall should be at least 96" (2438 mm) on all sides of the unit.
3. The distance between any two units within the walls should be at least 120" (3048 mm).

Do not locate outside air intakes near exhaust vents or other sources of contaminated air.

If the unit is installed where windy conditions are common, install wind screens around the unit, maintaining the clearances specified (see [Figure 21](#)). This is particularly important to prevent blowing snow from entering outside air intake and to maintain adequate head pressure control when mechanical cooling is required at low outdoor air temperatures.

For pad-mounted units, it is recommended that the condenser section be lifted a minimum of 12" off the ground for proper underside ventilation. This clearance allows for proper airflow, optimal condenser performance and to prevent any minor reductions in performance.

## Overhead Clearance

1. Unit(s) surrounded by screens or solid walls must have no overhead obstructions over any part of the unit.
2. The area above the condenser must be unobstructed in all installations to allow vertical air discharge.
3. The following restrictions must be observed for overhead obstructions above the air handler section (see [Figure 22](#)):
  - a. There must be no overhead obstructions above the furnace flue, or within 9" (229 mm) of the flue box.
  - b. Overhead obstructions must be no less than 96" (2438 mm) above the top of the unit.
  - c. There must be no overhead obstructions in the areas above the outside air and exhaust dampers that are farther than 24" (610 mm) from the side of the unit.

**Figure 22: Overhead Clearance**

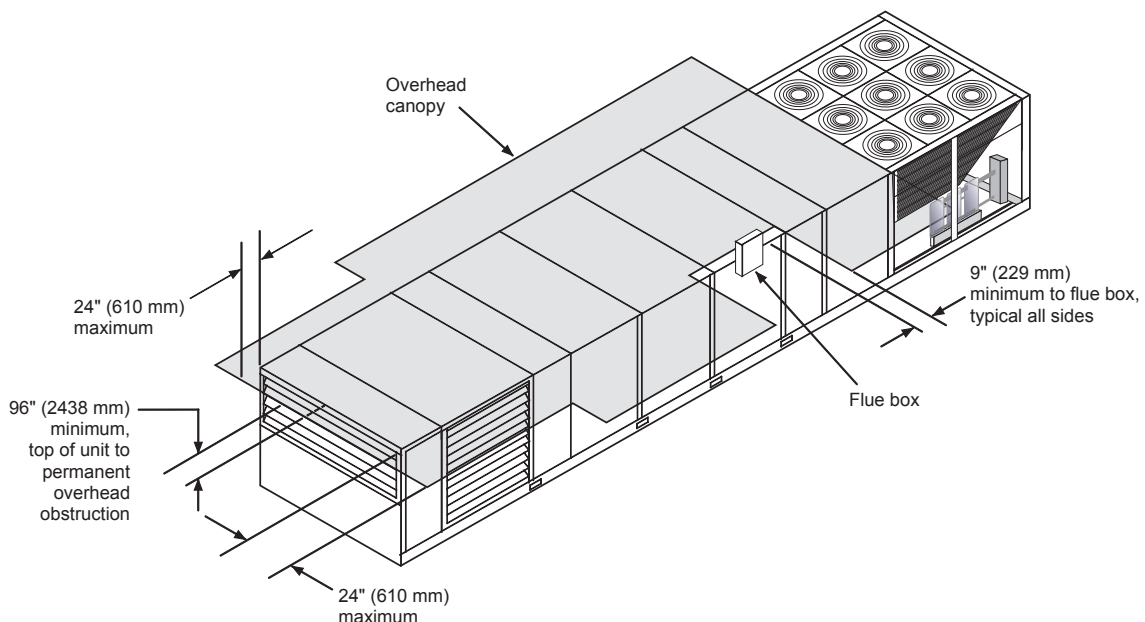

## Roof Curb Assembly and Installation

Locate the roof curb and unit on a portion of the roof that can support the weight of the unit. The unit must be supported to prevent bending or twisting of the machine.

If building construction allows sound and vibration into the occupied space, locate the unit over a non-critical area. **It is the responsibility of the system designer to make adequate provisions for noise and vibration in the occupied space.**

Install the curb and unit level to allow the condensate drain to flow properly and allow service access doors to open and close without binding.

Integral supply and return air duct flanges are provided with the RPS/RFS roof curb, allowing connection of duct work to the curb before the unit is set. The gasketed top surface of the duct flanges seals against the unit when it is set on the curb.

**WARNING**

Mold can cause personal injury. Some materials such as gypsum wall board can promote mold growth when damp. Such materials must be protected from moisture that can enter units during maintenance or normal operation.

These flanges must not support the total weight of the ductwork. See [Installing Ductwork on page 44](#) for details on duct connections. It is critical that the condensate drain side of the unit be no higher than the opposite side.

Assembly of a typical RPS/RDT roof curb is shown in [Figure 24](#). Parts A through K are common to all units having bottom supply and return openings. Depending on the unit length, Parts L and M may be included with the roof curb kit to create the correct overall curb length.

### RCS Assembly instructions

[Figure 23](#) shows the assembly of the RCS roof curb.

1. Set curbing parts (A) in place making sure that the orientation complies with the assembly instructions. Check alignment of all mating bolt holes.
2. Bolt curbing parts together using fasteners provided.
3. Curb must be level from side to side and over its length.
4. Weld curbing in place. Caulk all seams watertight and insulate between channels.
5. Flash curbing into roof as shown in Detail C.

**Figure 23: RCS Roof Curb Assembly**

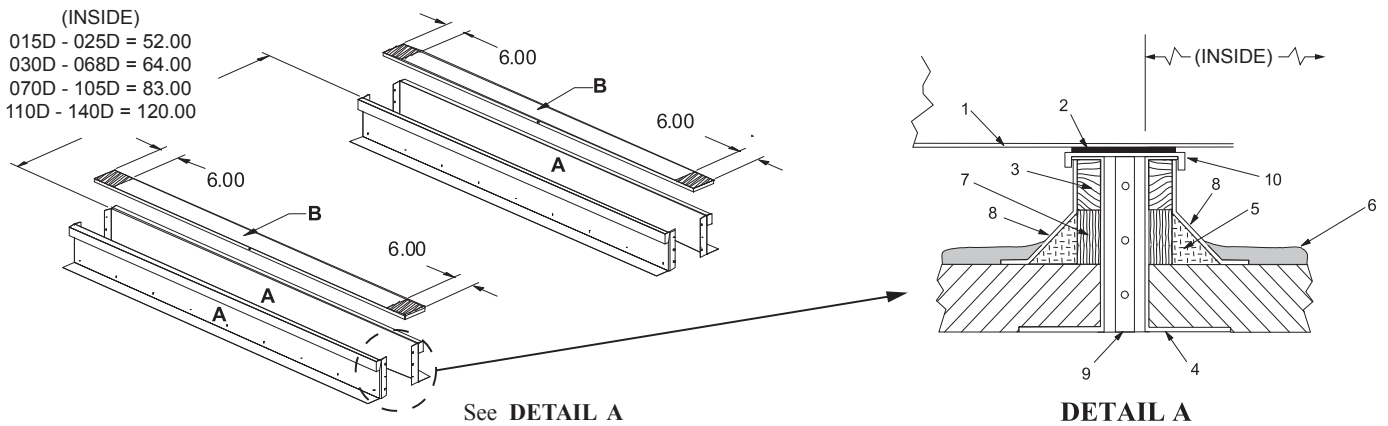

1. Unit Base
2. Curb gasketing
3. 2 x 4 nailer strip
4. Galvanized curb
5. Cant strip - NOT FURNISHED
6. Roofing material - NOT FURNISHED
7. Rigid insulation - NOT FURNISHED
8. Flashing - NOT FURNISHED
9. Insulation between galvanized curb - NOT FURNISHED
10. Galvanized curb cover

**NOTE:** All dimensions in inches

**RPS/RDT Assembly instructions (Figure 24)**

1. Set curbing parts A through K per dimensions shown over roof opening or on a level surface. Note location of return and supply air openings.
2. If applicable, set other curbing parts (D, L, M, etc.) in place making sure that the orientation complies with the assembly instructions. Check alignment of all mating bolt holes. See Detail A.
3. Bolt curbing parts together using fasteners provided. Tighten all bolts finger tight.
4. Square entire curbing assembly and securely tighten all bolts.
5. Position curb assembly over roof openings. Curb must be level from side to side and over its length. Check that top surface of the curb is flat with no bowing or sagging.
6. Weld curbing in place. Caulk all seams watertight. Remove backing from 0.25" (6 mm) thick x 1.50" (38 mm) wide gasketing and apply to surfaces shown by cross-hatching.
7. Flash curbing into roof as shown in Detail B.
8. Parts E and F are not required on units with no return shaft within the curb perimeter.
9. Parts G and H are not required on units with no supply shaft within the curb perimeter.
10. Be sure that electrical connections are coordinated (see Figure 25).

**Figure 24: RPS/RFS Roof Curb Assembly**

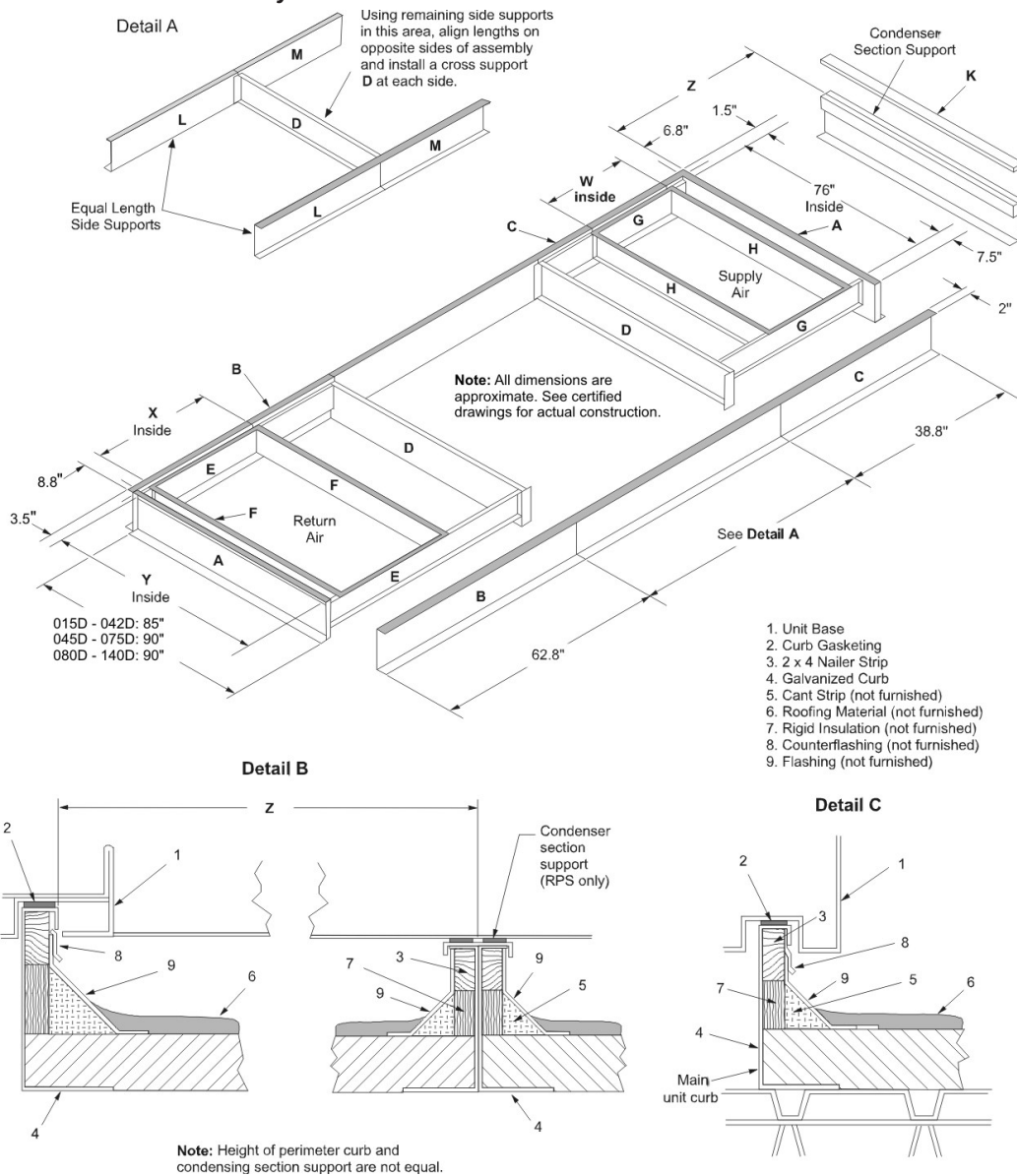
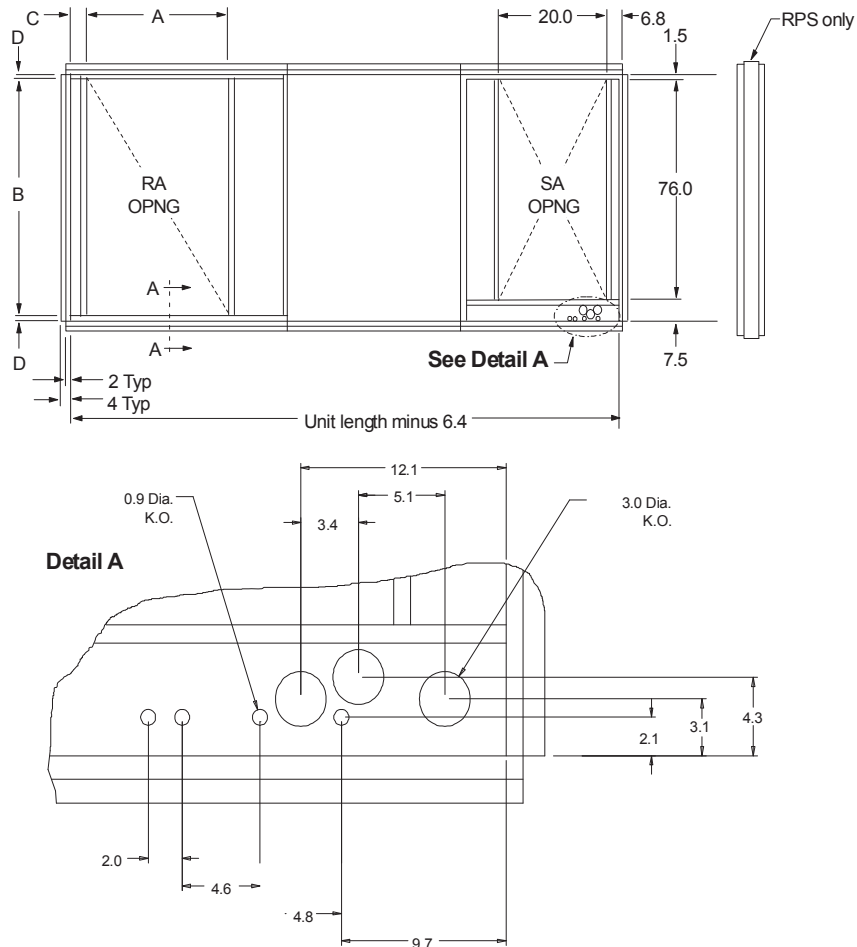

**Table 6: RPS/RFS Roof Curb Assembly Dimensions**

Unit size	Return Fan	X	Y
		in. (mm)	in. (mm)
015 – 042	2 × 15" FC	24 (610)	82 (2083)
	30" AF	30 (762)	76 (1930)
	40" AF	36 (914)	78 (1981)
	None	24 (610)	82 (2083)
045 – 079	All units	38.0 (965)	87.0 (2210)
080 – 140	All units	62.0 (1575)	87.0 (2210)
Unit size		Z	W
015, 020, 025		53.6 (1361)	—
015D – 025D		—	20 (508)
030		56.2 (1427)	—
030D		—	20 (508)
035, 040		57.3 (1455)	—
035D – 040D		—	20 (508)
045, 050, 062, 068		61.0 (1594)	—
045D – 075D		—	28.0 (711)
010, 021, 026, 031, 042, 051, 061, 070-080, 085, 090, 100, 105		74.0 (1880)	—
080D – 090D		—	38.0 (965)
081, 091, 101, 110-140		99.0 (2514)	—
100D – 140D		—	46.0 (1168)

Note: These dimensions do not apply to units with energy recovery wheels.

**Figure 25: Typical Power Wire Entrance, Curb View (RPS/RFS 045D to 140D shown, See Project Certified Drawings)**



## Post and Rail Mounting

**CAUTION**

The unit must be level side to side and over the entire length. Equipment damage can result if the unit is not level.

When mounting by post and rail, run the structural support the full length of the unit. Locate the structural member at the base of the unit as shown in Figure 26, assuring the I-beam is well supported by the structural member.

If resilient material is placed between the unit and the rail, insert a heavy steel plate between the unit and the resilient material to distribute the load. Seal cabinet penetrations (electrical, piping, etc.) properly to protect against moisture and weather.

Figure 26: Post and Rail Mounting

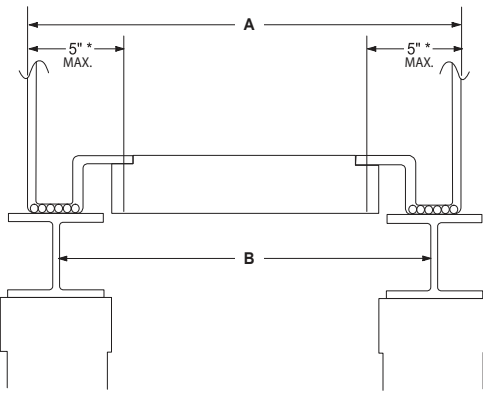

\* Beam can extend beneath unit no more than 5" to allow adequate space for duct connections and electrical entry.

Table 7: Post and Rail Mounting Dimensions

Unit Size		15-42	45-140
A	Condensing Unit	99"	99"
	Air Handler	94"	
B	—	93"-94"	97"

## Lifting Guidance

Daikin Applied equipment is designed to withstand the loads of the lifting and rigging process resulting from ASME Standard P30.1 - Planning for Load Handling Activities or equivalent. Lifting guidance is intended for installations of newly delivered equipment. If moving previously installed equipment for re-location or disposal, consideration should be given to unit condition. Equipment should also be drained as unit weight and center of gravity values do not reflect the addition of water for lifting.

**DANGER**

Improper rigging, lifting, or moving of a unit can result in unit damage, property damage, severe personal injury, or death. See the as-designed, certified dimensioned drawings included in the job submittal for the weights and center of gravity of the unit. If the drawings are not available, consult the local Daikin Applied sales office for assistance.

Installation is to be performed only by qualified personnel who are familiar with local codes and regulations, and experienced with this type of equipment. Lifting equipment and mechanisms must be determined by the Lifting Director per the current version of ASME Standard P30.1 or equivalent and must be suited for the load capacity. Daikin Applied is not a licensed nor certified rigging specialist. Therefore it is the customer's responsibility to consult a certified rigging contractor to rig, lift, and move components and subcomponents properly and safely as needed.

**CAUTION**

Forklifts may not be used to lift or move RoofPak units as the method may result in unit damage.

**CAUTION**

When around sharp edges, wear appropriate Personal Protective Equipment (PPE), such as gloves, protective clothing, foot wear, eye protection, etc. to prevent personal injury.



**Lifting Brackets**

Lifting bracket or hole designs vary from product to product. Rules of engagement with the lifting point are the same regardless of the attachment type. For RoofPak units, a typical lifting bracket with 2" (51 mm) diameter holes found on the sides of the unit base are illustrated in Figure 27. See the as-designed certified drawings for specific lifting points on this product model.

Engagement with each bracket is to be as close to vertical as possible. The maximum allowable lift angle from the vertical is 30 degrees as shown in Figure 28. If the lift angle shifts beyond 30° from vertical on any of the lift points, the lift shall not proceed until a plan and rigging can be secured that will correct the angle of lift.

**WARNING**

The lifting angle must not go beyond 30 degrees from vertical or the unit can become unstable which may result in unit damage, property damage, severe personal injury, or death.

**Figure 27: Illustration of Lifting Bracket and Allowed Angle for Lifting**

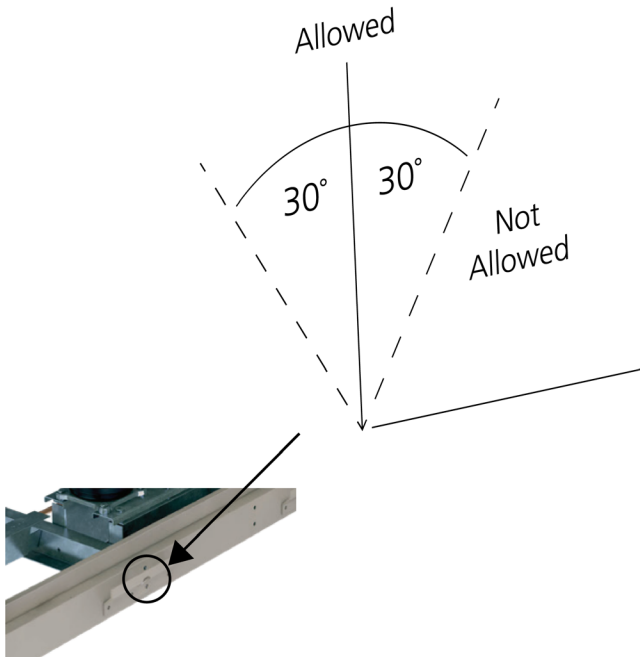

**Figure 28: Illustration of Allowed Angle Label**

**WARNING**

All factory provided lifting points must be used. Unit must remain level during lift and transit!

The lifting and tie-down angle must not go beyond 30 degrees from vertical or the unit can become unstable which may result in unit damage, property damage or severe personal injury or death.

The diagram shows a unit with four lifting points. Two are labeled 'Lifting Straps +/- 30°' and two are labeled 'Tie-Down +/- 30°'. The unit is shown in a tilted position, indicating instability.

**Lifting Equipment**

Lifting equipment is supplied by the user or their designate. This is typically selected around the unit certified information of the equipment to be lifted and the available lifting equipment planned to be at the site where the lift is to take place. It is the responsibility of the Lifting Director to follow a standard practice of lift planning and equipment selection, like that found in the ASME P30 series of standards. Lifting plan and equipment must ensure that the only contact with the unit is at that lifting brackets. Straps, chains or spreader bars that are likely to be used shall not come in contact with the unit.

**CAUTION**

Lifting mechanisms must not make contact with the unit beyond the lifting bracket. Extreme care must be used when rigging the unit to prevent damage to the control panels, unit handles, unit piping, and unit frame.

**Lifting Points**

Lifting points are predetermined by design. When lifting, all factory installed lifting brackets must be used. Figure 29 illustrates typical 4 point and 6 point lifting configurations. Unit must remain level throughout the entire lifting event. Level is defined as one end being no more than 0.25" per foot of unit length to the opposite end.

**⚠ WARNING**

Be aware that the center of gravity may not necessarily be in the geometric center of the unit. No additional items can be added to a lift with the unit as it may affect the center of gravity and cause unit damage, property damage, severe personal injury, or death. Refer to as-designed, certified drawings for weight, center of gravity location and details specific to unit configuration.

**Figure 29: Typical Lifting Points Locations**

**4 Lifting Points**

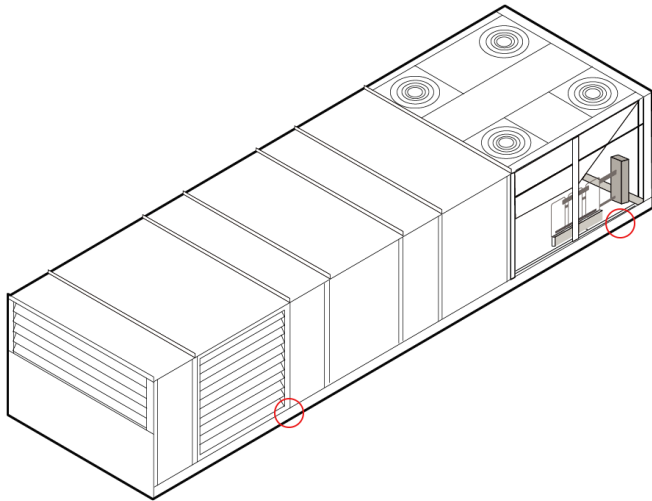

**6 Lifting Points**

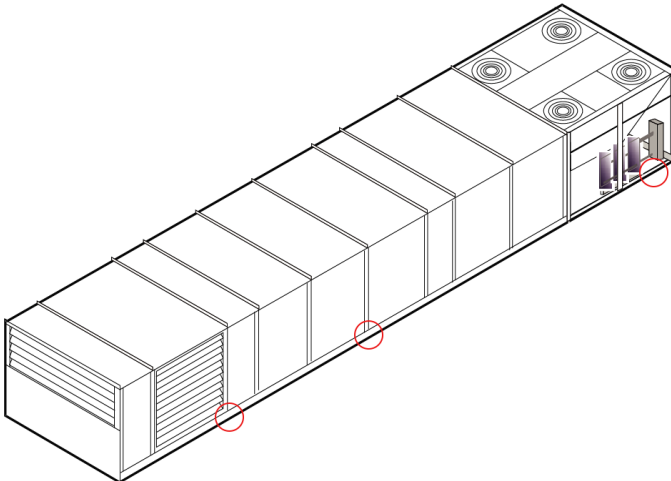

## Transit and Temporary Storage

If the unit is stored for an intermediate period before installation or moved to a different location, take these additional precautions:

1. Support the unit well along the length of the base rail.
2. Level the unit (no twists or uneven ground surface).
3. Provide proper drainage around the unit to prevent flooding of the equipment.
4. Provide adequate protection from vandalism, mechanical contact, etc.
5. Securely close the doors and lock the handles.
6. If there are isolation dampers, make sure they are properly installed and fully closed to prevent the entry of animals and debris through the supply and return air openings.
7. Cover the supply and return air openings on units without isolation dampers.
8. Long term storage in humid environments may cause condensate corrosion on steel surfaces. Consider adding a desiccant material to alleviate corrosion concerns.

When the unit is being tied down for transit, the maximum allowable attachment angle from the vertical is 30 degrees in the opposite direction of lifting in [Figure 28](#). Shimming of the unit under the lifting brackets or tie-down points must be used to ensure even contact along the length of the base rail.

## Reassembly of Split Units

Although RoofPak units typically ship from the factory as complete units, they may be split at the factory in one of two possible configurations; see (1) "RPS Factory Split at Fan", [Figure 30](#) and (2) "RFS/RCS Permanent Split Systems" on [page 30](#).

### RPS Factory Split at Fan

The RPS unit is factory split at the fan section and ships as two pieces, split at the supply fan bulkhead, to recouple together on the roof. Like the RPS/RDT unit factory split at the condenser, this configuration is ordered if shipping length or weight limitation prevents a packaged RPS/RDT from being ordered. Splitting at the fan has the advantage of leaving all factory refrigerant piping intact so field evacuation and charging is not required. Detailed instructions are on [page 30](#) to [page 29](#).

A single nameplate is attached to the air handler section and

power is fed to both sections through the main control box, as in a non-split RPS/RDT unit.

Field reassembly of an RPS/RDT unit that has shipped split at the fan takes place in three phases: (1) setting the sections (2) mechanically recoupling the cabinet, and (3) reconnecting power and control wiring.

#### Phase I. Set sections (Figure 30)

1. Remove top cap and save for Step 3.
2. Remove screws on fan panel, leaving retainer clips in place to secure bulkhead. Save screws for Phase II, Step 5.
3. Remove plywood and retaining angles from unit and discard.
4. Carefully lower both sections of unit (fan end and discharge end) into place, making sure the roof curb engages the recesses in the unit base.

**Figure 30: Set Sections - Steps 1-4, RPS Factory Split at Supply Fan**

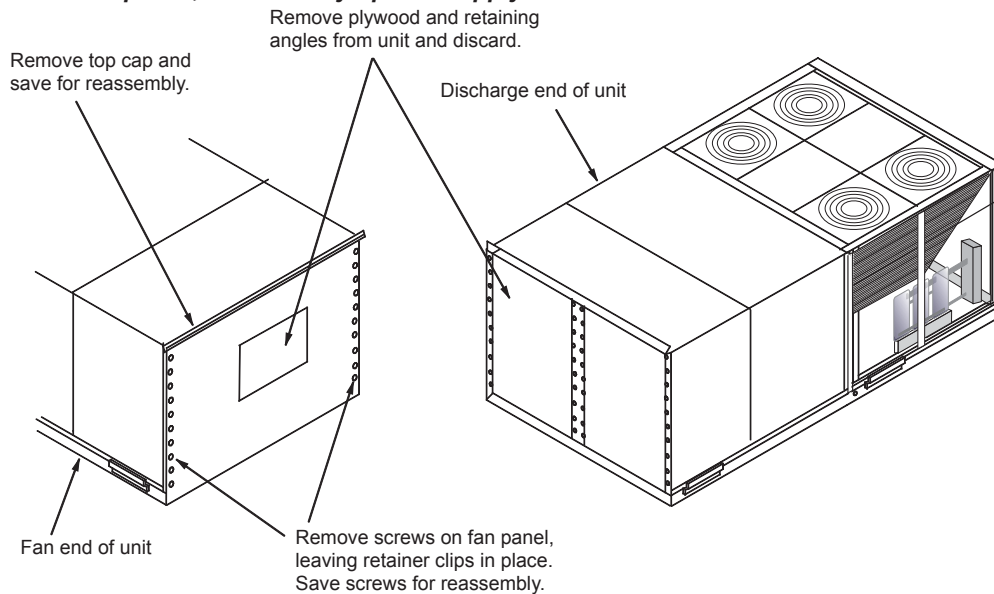

**Phase II. Reassemble cabinet (Figure 31)**

1. Reinstall top cap removed in Phase I, Step 1.
2. Caulk (watertight) ends of splice cap.
3. Caulk (watertight) vertical seam.
4. Install #10 screws (provided).
5. Install screws (.25–20 × 0.75) removed in Phase I, Step 2.
6. Install splice cover (provided).

**Figure 31: Reassemble Cabinet**

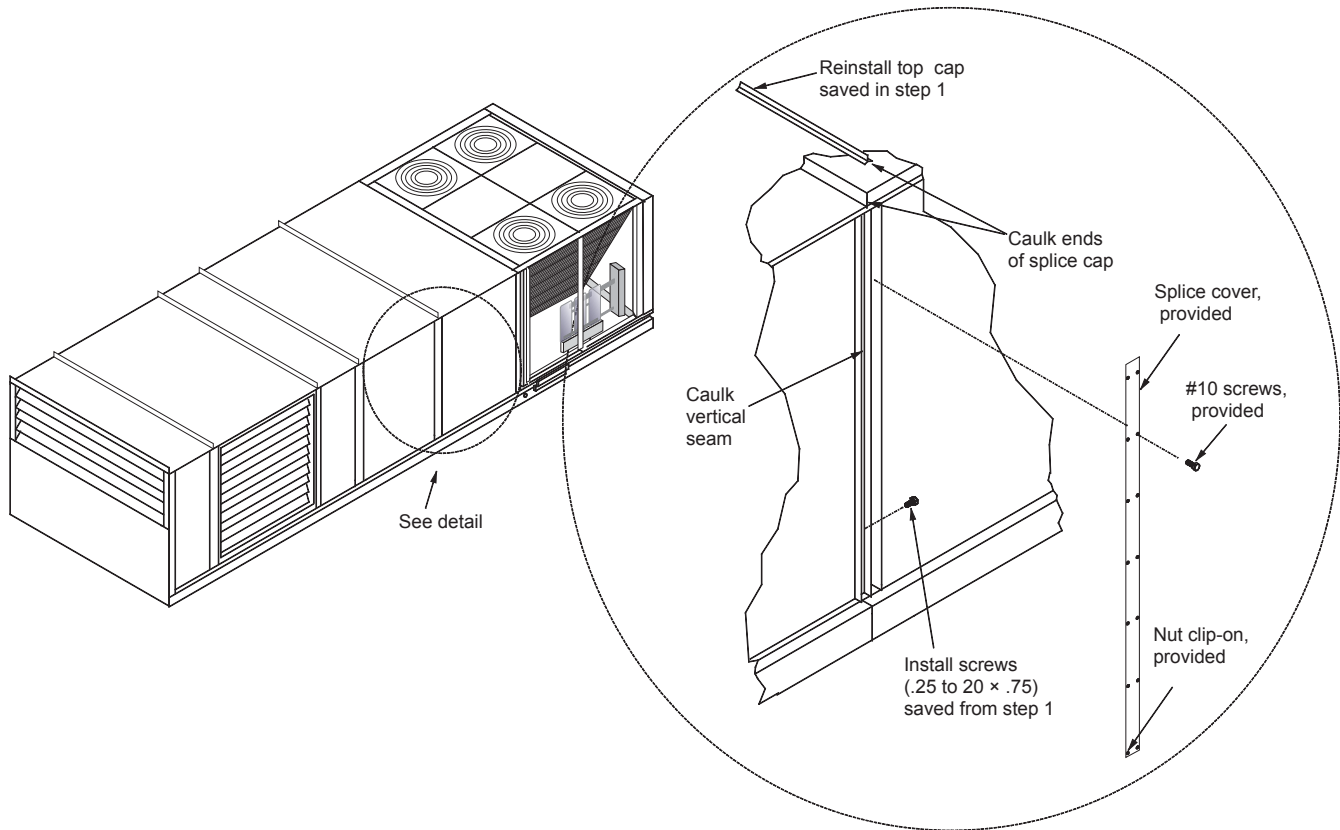

**Phase III. Reconnect Power and Control Wiring**

**CAUTION**

Connect the power block correctly and maintain proper phasing. Improper installation can cause severe equipment damage.

The DX coil/condenser section contains power and control harnesses that have their excess length in the blank or heat section, which normally is immediately downstream of the fan. Once the sections are physically reconnected, the ends of the power harness are fed back through the unit base into the junction box, per the unit's electrical schematics.

1. Make electrical connections and reinstall inner raceway cover as shown in [Figure 32](#).
2. When power wire reconnection is complete, reinstall the inner raceway cover in the blank or heat section. [Figure 32](#) shows a typical installation of the raceway cover.
3. Run the control harnesses by removing the external raceway covers on either side of the unit split.
4. Remove the excess harness length from the external raceway on the DX side of the split; then route along the raceway through the bushed hole in the fan section and into the junction box where control wiring terminal blocks are provided for reconnection.
5. Make all electrical connections per the unit's electrical schematics.
6. Reinstall the external raceway covers after routing of the control wires is complete.
7. Draw through cooling coils only. Reconnect refrigerant piping. These refrigerant circuits for these units are shipped with a holding charge only. [Figure 33](#) illustrates what the installer sees at the shipping split
  - a. To bridge the gap and connect the piping, remove the refrigerant piping caps and add fittings and copper tubing, as required.
  - b. Evacuate and charge the unit. See [page 32](#) for further details.

**Figure 32: Electrical Connections/Cover Installation**

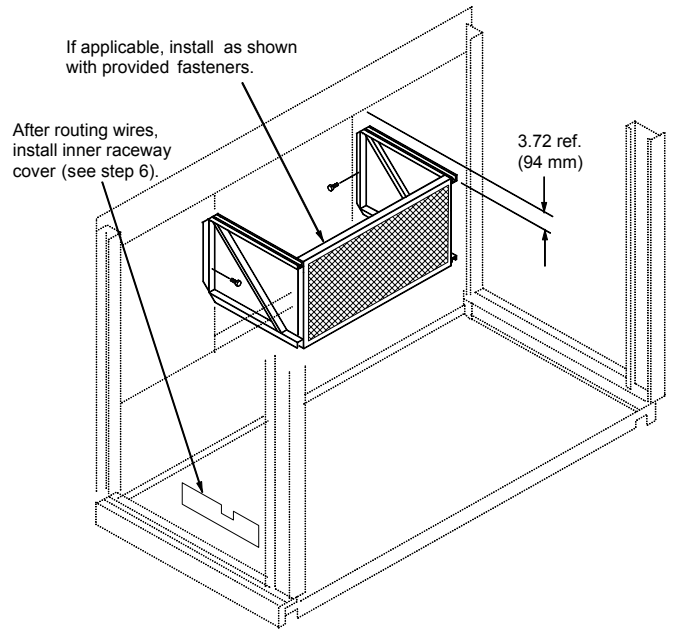

**Figure 33: Refrigerant Lines**

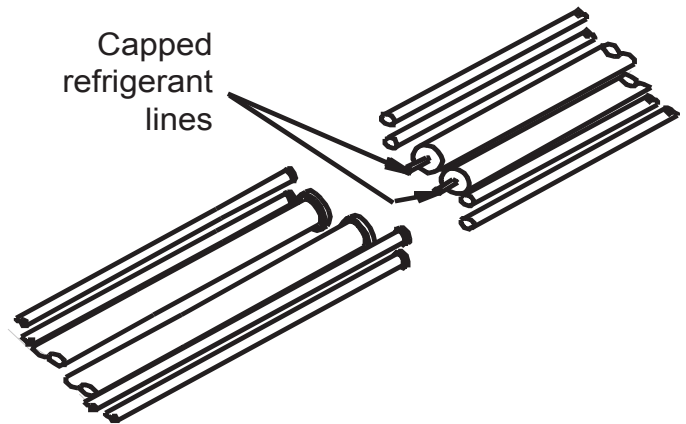

## RFS/RCS Permanent Split Systems

**NOTE:** Not available on variable speed inverter compressor units.

The RFS air handler section and RCS condenser section ship as two separate units. This configuration is ordered when the condenser is intended to remain separated by a short distance from the air handler because of space or structural constraints.

On all units, refrigerant piping is terminated near the exterior of the cabinet for convenient field piping between the RCS and RFS units, and all necessary refrigeration components are provided (except the field-installed hot gas bypass valve). Detailed instructions are on [page 32](#) to [page 35](#).

The hot gas bypass valve should be located as close to the RCS as possible to minimize refrigerant from accumulating in the HGBP piping. Units with a VFD compressor option do not require HGBP as the compressor is capable of modulating. Minimize pipe bends (especially those that accumulate refrigerant) as much as possible. Connect the pressure sensing tap to the suction line.

### Piping Recommendations

All field piping, wiring, and procedures must be performed in accordance with ASHRAE, EPA, and industry standards. Proper refrigerant piping can make the difference between a reliable system and an inefficient, problematic system.

The primary concerns related to piping are refrigerant pressure drop, a solid liquid feed to the expansion valves, continuous oil return and properly sized refrigerant specialties.

Insulate the suction line to reduce excessive superheat buildup. Insulate the liquid line, where located in areas above ambient temperature, to prevent loss of subcooling and consequent liquid flashing.

The recommended source for refrigerant piping techniques and sizing is the [Daikin Applied AG31-011 Refrigerant Piping Design Guide](#).

Although conflicting piping recommendations can be found in different sources, Daikin Applied offers the following recommendations for these controversial issues.

The use of double risers for vertical gas risers is generally not required and should be used only as a last resort to maintain the minimum refrigerant flow to carry oil up the vertical risers. Slightly downsizing the vertical riser is a preferable option to providing double risers.

Slope the refrigerant lines ½" to 1" per 10 feet of horizontal run in the direction of refrigerant flow to assist oil return.

Pressure drops in the refrigerant lines should be maintained at or below the ASHRAE recommendations and line lengths should be made as short as possible. Exceeding these recommendations will decrease performance and could impact reliability.

Small traps should be provided at the base of each major vertical gas riser to assist in the collection of oil. If vertical risers exceed more than 25 feet, install a small trap at the midpoint and at a maximum of 20 foot intervals.

Use caution in sizing the liquid line in applications where the evaporator is above the outdoor section. The weight of the liquid refrigerant in the vertical column will decrease the pressure at the top of the riser (approximately 0.5 psi per foot of vertical rise) allowing some of the refrigerant to flash to a gas. Adequate refrigerant subcooling is needed at the outdoor section to prevent large volumes of refrigerant gas at the expansion valve.

The piping systems should always extend above the highest component in the refrigeration system before dropping down to make the final refrigerant connections to components. This practice will hinder the draining of condensed refrigerant to the lower component when normal shutdown procedures do not occur (such as a power failure).

**NOTE:** Do not run refrigerant lines underground.

1. Use type K or L clean copper tubing. Thoroughly clean or braze all joints with high temperature solder. Make sure nitrogen is flowing through the tubes while brazing to minimize the formation of oxide contaminants.
2. Base piping sizes on temperature/pressure limitations as recommended in the following paragraphs. Under no circumstances should pipe size be based strictly upon coil or condensing unit piping connection size.
3. To determine the minimum tonnage required to carry oil up suction risers of various sizes, check the vertical suction risers using [Table 8](#).
4. Size the liquid line for a pressure drop not to exceed the pressure equivalent of 2°F (1°C), 6 psi (41.4 kPa) saturated temperature. The filter drier, solenoid, and sight glass ship loose with each RFS unit.

**Table 8: Minimum Tonnage (R-410A) to Carry Oil Up Suction Riser at 40°F Saturated Suction**

Line size O.D.	Minimum tonnage
1-1/8"	2.0
1-3/8"	3.5
1-5/8"	5.4
2-1/8"	11.2
2-5/8"	19.5
*3-1/8"	30.5

\* Daikin Applied's largest suction connection is 2-5/8" and is generally sufficient.

Piping Connections, RFS/RCS Units

Figure 34: Refrigerant Piping Connection Locations Example

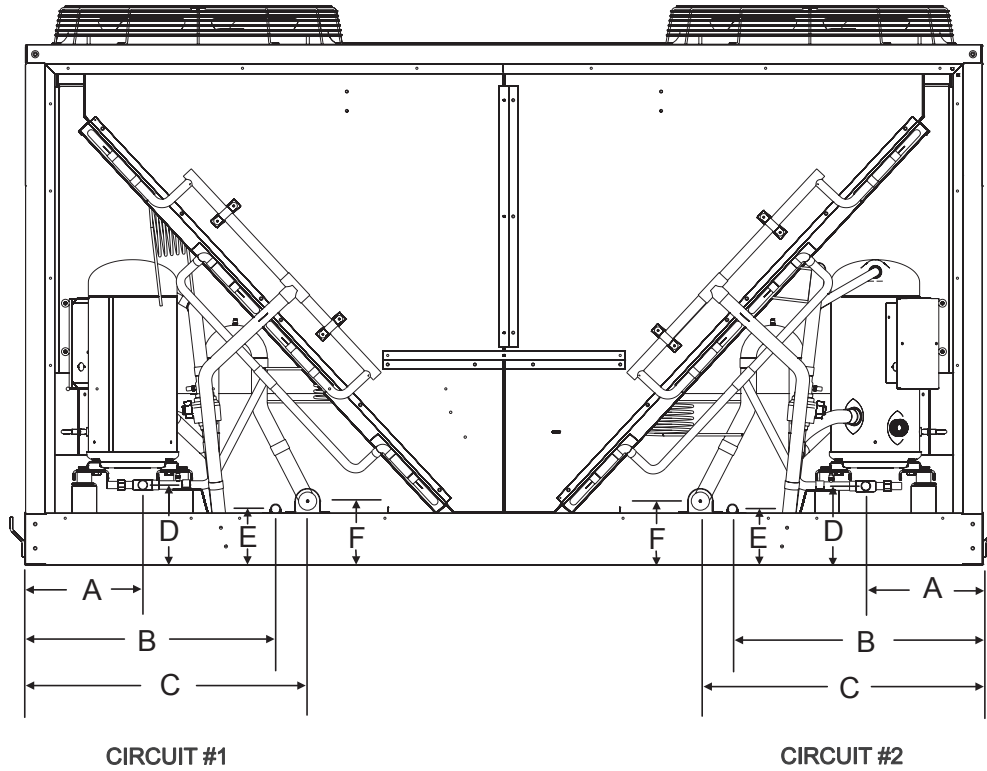

Table 9: 015D – 140D Connection Sizes and Locations\*

Dimension	Component	Circuit	Piping Dimension (inches)					
			015D - 026D	030D - 042D	045D - 068D	070D - 079D	080D - 105D	110D - 140D
A	Liquid line #1/#2	Ckt.1 & 2	16.7	12.9	12.0	13.5	11.2	20.8
B	HGBP line #1/#2	Ckt.1 & 2	24.0	25.4	25.9	25.9	28.1	25.9
C	Suction line #1/#2	Ckt.1 & 2	32.7	29.3	29.4	32.3	32.3	32.4
D	Liquid line #1/#2	Ckt.1 & 2	8.38	8.38	8.38	8.38	8.38	8.38
E	HGBP line #1/#2	Ckt.1 & 2	6.02	6.02	6.02	6.02	6.02	6.02
F	Suction line #1/#2	Ckt.1 & 2	6.62	6.62	6.62	6.62	6.62	6.62

Table 10: 015D – 140D Piping Diameter\*

Component	Circuit	Piping Diameter (inches)										
		015D - 016D	020D - 021D	025D - 026D	030D - 031D	035D	042D	045D	050D - 051D	061D	063D	068D
Liquid line #1/#2	Ckt.1 & 2	5/8	5/8	7/8	7/8	7/8	7/8	7/8	7/8	7/8	7/8	7/8
HGBP line #1/#2	Ckt.1 & 2	7/8	7/8	7/8	7/8	7/8	7/8	7/8	7/8	7/8	7/8	7/8
Suction line #1/#2	Ckt.1 & 2	1-5/8	1-5/8	1-5/8	1-5/8	1-5/8	1-5/8	1-5/8	1-5/8	1-5/8	1-5/8	1-5/8
Component	Circuit	Piping Diameter (inches)										
		070D - 071D	075D - 079D	080D - 081D	085D	090D - 091D	100D - 101D	105D	110D	120D	125D	140D
Liquid line #1/#2	Ckt.1 & 2	7/8	7/8	1-1/8	1-1/8	1-1/8	1-1/8	1-1/8	1-1/8	1-1/8	1-1/8	1-1/8
HGBP line #1/#2	Ckt.1 & 2	7/8	7/8	7/8	7/8	7/8	7/8	7/8	7/8	7/8	7/8	7/8
Suction line #1/#2	Ckt.1 & 2	2-5/8	2-5/8	2-5/8	2-5/8	2-5/8	2-5/8	2-5/8	2-5/8	2-5/8	2-5/8	2-5/8

\* For fixed speed compressors only

**Holding Charge**

**WARNING**

Before applying heat to remove brazed piping caps and plugs, always vent piping to atmosphere. Failure to do so can cause hazardous pressures, explosion, severe personal injuries, or death.

The RFS unit and RCS unit ship with a nitrogen holding charge. At the time the unit was received, a visual inspection of the unit piping should have been made to be sure no breakage had occurred or that the fittings had not loosened. A pressure test on the RCS units should indicate a positive pressure in the unit. If no pressure is evident, the unit will have to be leak tested and the leak repaired. This should be noted and reported to the Daikin Applied sales representative and freight carrier if the loss is due to shipping damage.

**RCS**—Vent to atmosphere by opening gauge ports at the compressors and liquid line charging valves.

**RFS**—Vent to atmosphere by cutting off the process tubes on the suction line caps.

The RFS unit does not have gauge ports for pressure measurement. If no positive pressure is detected when cutting off the process tubes and removing the tubing caps, the unit should be leak tested as scribed below, after the interconnecting piping has been brazed in place. This test will also confirm the integrity of the field braze joints.

**Leak Testing**

**WARNING**

Do not use oxygen or air to build up pressure. Explosion hazard can cause severe personal injury or death.

In the case of loss of the nitrogen holding charge, the unit should be checked for leaks prior to charging the complete system. If the full charge was lost, leak testing can be done by charging the refrigerant into the unit to build the pressure to approximately 10 psig by adding sufficient dry nitrogen to bring the pressure to a maximum of 125 psig. The unit should then be leak tested with halide or electronic leak detector. After making any necessary repair, the system should be evacuated as described.

**Evacuation**

After determining the unit is tight and there are no refrigerant leaks, evacuate the system. Use a vacuum pump with a pumping capacity of approximately 3 cubic ft./min. and the ability to reduce the vacuum in the unit to at least 1 mm (1000 microns).

1. Connect a mercury manometer or an electronic or other type of micron gauge to the unit at a point remote from the vacuum pump. For readings below 1 millimeter, use an electronic or other micron gauge.
2. Use the triple evacuation method, which is particularly helpful if the vacuum pump is unable to obtain the desired 1 mm of vacuum. The system is first evacuated to approximately 29" (740 mm) of mercury. Then add enough refrigerant vapor to the system to bring the pressure up to 0 pounds (0 microns).
3. Evacuate the system again to 29" (740 mm) of vacuum. Repeat his procedure three times. This method is most effective by holding system pressure at 0 pounds (0 microns) for a minimum of 1 hour between evacuations. The first pull-down removes about 90% of the non-condensables; the second removes about 90% of that remaining from the first pull-down. After the third pull-down, only 1/10 of 1% of non-condensables remains.

Table 13 shows the relationship between pressure, microns, atmospheres, and the boiling point of water.

**CAUTION**

To prevent liquid return and damage to the compressor on systems with optional hot gas bypass, locate the bypass solenoid valve on the RCS, not on the RFS unit.

**CAUTION**

Before replacing refrigerant sensors or protective devices, see [Refrigerant Charge on page 35](#) for an important warning to prevent an abrupt loss of the entire charge.

**CAUTION**

Refrigerant charge in the system typically exceeds the capacity of the microchannel condenser. Removal of the refrigerant is required to service refrigerant components.

Compressors can be isolated from the system if optional service valves are installed in the discharge and suction lines.



**Table 11: Approximate R-410A Refrigerant Charge per Circuit, 015D to 140D**

Unit size	Base charge lbs per circuit (less DX coil)				DX coil charge lbs per circuit per coil row		Extra charge for MHGRH (Circuit 2 only)
	Blow through RPS		RDT or draw through RPS		DX=S*	DX=L*	
	Circuit #1	Circuit #2	Circuit #1	Circuit #2			
015D	15.85	14.85	—	—	2.8	—	0.7
020D	16.85	15.85	—	—	2.8	—	0.7
025D/025D†	21.35	20.35	—	—	2.8	—	0.7
030D	20.35	19.35	—	—	2.8	—	0.8
016D, 021D, 026D, 031D, 035D-042D	24.7	23.7	—	—	2.8	—	1.0
045D, 050D, 062D	22.94	21.94	26.94	25.94	4.1	4.5	1.7
051D, 063D	25	24	25	24	4.1	4.5	1.7
068D	22	21	26	25	4.1	4.5	1.7
070D, 075D	23	22	27	26	4.1	4.5	1.7
074D, 079D, 080D, 085D	24	23	28	27	4.7	5.3	2.5
090D	24	23	28	27	4.7	5.3	2.5
100D	24	23	28	27	5.3	6.7	2.5
081D, 091D, 101D, 105D	25	23	28	27	5.3	6.7	2.8
110D	35	34	39	38	5.3	6.7	2.9
120D	35	37	39	41	5.3	6.7	2.9
125D	38	3	42	41	—	6.7	2.9
130D	38	37	42	41	—	6.7	2.9
140D	38	40	42	44	—	6.7	2.9

\* DX coil configuration (S = Standard, L = Large) is identified by the 8th digit of the RPS/RDT or RFS model number, found on the unit nameplate. For example, DX = L for unit model number RFS060DLY. Above values are for sealed core driers. Add 3.3#/ckt for replaceable core driers.  
 † Variable speed inverter compressor

**Table 12: Weight of Refrigerant in Copper Lines (Pounds per 100 feet of Type L Tubing)**

O.D. line size (inches)	Vol. per 100 ft. in cubic feet	Weight of refrigerant, lbs./100 feet		
		Liquid @110°F (subcool to 15°F)	Hot gas@127°F cond. (superheat to 85°F)	Suction gas (superheat to 10°F)
		R-410A	R-410A	47°F set suction temp. R-410A
3/8	0.054	3.22	0.36	0.131
1/2	0.100	5.97	0.67	0.243
5/8	0.162	9.67	1.08	0.394
7/8	0.336	20.06	2.24	0.816
1-1/8	0.573	34.21	3.82	1.39
1-3/8	0.872	52.06	5.81	2.11
1-5/8	1.237	73.85	8.24	3.00
2-1/8	2.147	128.18	14.30	5.22
2-5/8	3.312	197.73	22.06	8.05
3-1/8	4.728	282.26	31.49	11.49
3-5/8	6.398	381.96	42.61	15.55
4-1/8	8.313	496.29	55.36	20.20

**Table 13: Pressure-Vacuum Equivalents**

Absolute pressure above zero Microns	Vacuum below 1 atmosphere		Boiling point of H <sub>2</sub> O at each pressure (°F)
	PSIA	Mercury, in. (mm)	
0	0	29.92 (760.0)	—
50	0.001	29.92 (759.95)	-50
100	0.002	29.92 (759.9)	-40
150	0.003	29.92 (759.85)	-33
200	0.004	29.91 (759.8)	-28
300	0.006	29.91 (759.7)	-21
500	0.009	29.90 (759.5)	-12
1,000	0.019	29.88 (759.0)	1
2000	0.039	29.84 (758.0)	15
4,000	0.078	29.76 (756.0)	29
6000	0.117	29.69 (754.0)	39
8,000	0.156	29.60 (752.0)	46
10,000	0.193	29.53 (750.0)	52
15,000	0.290	29.33 (745.0)	63
20,000	0.387	29.13 (740.0)	72
30,000	0.580	28.74 (730.0)	84
50,000	0.967	27.95 (710.0)	101
100,000	1.930	25.98 (660.0)	125
200,000	3.870	22.05 (560.0)	152
500,000	9.670	10.24 (260.0)	192
760,000	14.697	0	212

## Charging the System

**CAUTION**  
 Adding refrigerant to the suction must always be done by trained service personnel that are experienced with the risks associated with liquid-related damage to the compressor.

**CAUTION**  
 Units purchased for R-410A operation must be charged only with R-410A. Field mixing or changing of refrigerants can compromise performance and damage equipment.

RCS units are leak tested at the factory and shipped with a nitrogen holding charge. If the holding charge has been lost due to shipping damage, then contact the factory for authorization and advice for repairing the leak and evacuating the system.

1. After all refrigerant piping is complete and the system is evacuated, it can be charged as described in the paragraphs following. Connect the refrigerant drum to the gauge port on the liquid charging valve and purge the charging line between the refrigerant cylinder and the valve. Then open the liquid charging valve.
2. If the system is under a vacuum, stand the refrigerant drum with the connection up, open the drum, and break the vacuum with refrigerant gas.

3. With a system gas pressure higher than the equivalent of a freezing temperature, invert the charging cylinder and elevate the drum above the condenser. With the drum in this position and the valves open, liquid refrigerant flows into the condenser. Approximately 75% of the total requirement estimated for the unit can be charged in this manner.
4. After 75% of the required charge enters the condenser, close the liquid charging valve and reconnect the refrigerant drum and charging line to the suction side of the system. Again, purge the connecting line and stand the drum with the connection side up.
5. After charging is complete, torque the charging valve stem to 15 ft-lb.

**NOTE:** Use a backing wrench on the charging valve when torquing to eliminate stress on the piping.

Mark the total operating charge per circuit on the unit nameplate for future reference.

Take special care to add refrigerant slowly enough to the suction to prevent damage when first adding charge to the suction. Adjust the charging tank hand valve extremely slow such that only liquid leaves the tank but vapor enters the compressor.

**Table 14: Acceptable Refrigerant Oils**

R-410A (polyester [POE] oils)
Copeland ULtra 22 CC
Copeland ULtra 32-3MAF
ICI EMKARATE RL™ 32CL
Mobil EAL™ Arctic 22 CC

**Note:** Do not use mineral oils with R-410A.

## Refrigerant Charge

Each unit is designed for use with R-410A. The total charge per circuit is the sum of the following four values:

- Condenser section charge, see [Table 11 on page 33](#).
- Evaporator coil charge, see [Table 11](#).
- Charge for length of unit piping to the evaporator coil, see [Table 11](#).
- Charge for length of interconnecting piping between the RCS and RFS units, installed by field, see [Table 12](#). The exact charge for a one piece RPS/RDT is on the unit nameplate.

### Field Charging Procedure

Under normal (summertime) operating conditions, the superheat at the compressor should be between 8°F and 14°F and subcooling measured at the condenser outlet should be 15°F (nominal).

With all compressors operating at full capacity, a 25°F-35°F temperature difference should exist between the entering condenser air and the temperature corresponding to the compressor saturated discharge pressure.

For VFD compressor units, set the VFD compressor capacity to 100% before measuring subcooling.

The recommended method for field charging would be to recover, evacuate and re-charge the system to the value on the unit nameplate. If this method is not practical or verification of charge is the purpose, then unit charge can best be evaluated by the amount of subcooling.

Follow [Table 15](#) below for acceptable subcooling levels. To calculate subcooling: take the difference between the liquid temperature leaving the condenser and the temperature corresponding to the compressor saturated discharge pressure. **It is important not to use the saturation pressure at the condenser outlet as this will lead to an overcharged state.** When charging at ambients below 75°F it is strongly recommended to recover, evacuate and re-charge the unit to the value on the unit nameplate.

**Table 15: Typical Subcooling Operating Values**

Outdoor Ambient	Subcooling Range (see notes)
75–85°F	5–10°F
85–95°F	10–15°F
95–105°F	15–20°F

1. All compressors in circuit operating at full capacity
2. All condenser fans operating
3. Speedtrol condenser fan motor(s) operating at 100% (if option present)
4. Hot Gas Bypass not operating
5. MHGRH and liquid subcooling should not be operating

These units contain a microchannel condenser and the internal volume of the refrigeration system is less than that compared to a typical fin-tube condenser. Unit refrigerant charge can be as much as 40% less with microchannel and is much more sensitive to charge levels. Caution should be exercised not to overcharge the unit.

### Refrigeration Service Valves

Units are shipped with a liquid line charging valve in each circuit. RDT, RPS and RCS units have the following:

**RDT, RPS and RCS Units**—One liquid charging valve is provided per refrigeration circuit, located at end of condensing section opposite condenser control box.

**Optional**—One discharge valve and one suction valve is provided for each refrigerant circuit, located in the condenser section. If the unit contains a discharge and suction valve, verify that the valves are open before attempting to start the compressors.

**RFS units**—do not contain service valves.

## Unit Piping

### Condensate Drain Connection

**WARNING**

Drain pans must be cleaned periodically. Material in uncleaned drain pans can cause disease.

Cleaning should be performed by qualified personnel.

The unit is provided with a 1.5" male NPT condensate drain connection. Refer to certified drawings for the exact location. For proper drainage, level the unit and drain pan side to side and install a P-trap.

RPS units may have positive or negative pressure sections. Use traps in both cases with extra care given to negative pressure sections. In Figure 35, dimension "A" should be a minimum of 8" (203 mm). As a conservative measure to prevent the cabinet static pressure from blowing or drawing the water out of the trap and causing air leakage, dimension A should be two times the maximum static pressure encountered in the coil section in inches w.c.

Draining condensate directly onto the roof may be acceptable; refer to local codes. Provide a small drip pad of stone, mortar, wood, or metal to protect the roof against possible damage.

If condensate is piped into the building drainage system, pitch the drain line away from the unit a minimum of 1/8" per foot. The drain line must penetrate the roof external to the unit. Refer to local codes for additional requirements. Sealed drain lines require venting to provide proper condensate flow.

Where the cooling coils have intermediate condensate pans on the face of the evaporator coil, copper tubes near both ends of the coil provide drainage to the main drain pan. Check that the copper tubes are in place and open before the unit is put into operation.

On units with staggered cooling coils, the upper drain pan drains into the lower coil drain pan through a copper tube near the center of the drain pan. Check that this tube is open before putting the unit into operation and as a part of routine maintenance.

Drain pans in any air conditioning unit have some moisture in them, allowing micro-organisms to grow. Therefore, periodically clean the drain pan to prevent this buildup from plugging the drain and causing the drain pan to overflow.

Figure 35: Condensate Drain Connection

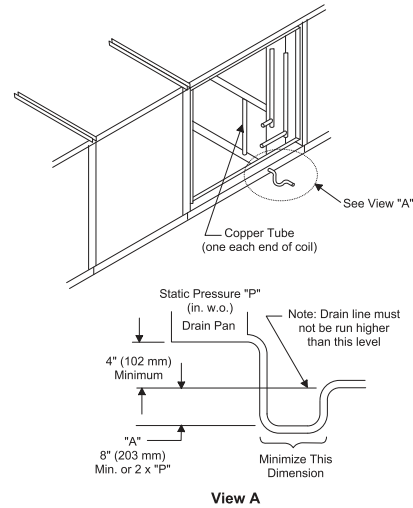

### Gas Piping

See the "Installation" section of the gas-fired furnace installation manual, [IM 684](#) or [IM 685](#).

### Hot Water Coil Piping

**CAUTION**

Coil freeze possible. Can damage equipment. Follow instructions for mixing antifreeze solution used. Some products have higher freezing points in their natural state than when mixed with water. The freezing of coils is not the responsibility of Daikin Applied. Refer to [Winterizing Water Coils on page 130](#).

Hot water coils are provided without valves for field piping or piped with three-way valves and actuator motors.

**NOTE:** All coils have vents and drains factory installed.

Hot water coils are not normally recommended for use with entering air temperatures below 40°F (4°C). No control system can guarantee a 100% safeguard against coil freeze-up. Glycol solutions or brines are the only freeze-safe media for operation of water coils at low entering air temperature conditions.

When no factory piping or valve is included, the coil connections are 1-5/8" ODM copper.

**NOTE:** With the factory piping and valve package, field piping connections are the same NPT size as the valve with female threading (see [Figure 37](#)).

Refer to the certified drawings for the recommended piping entrance locations. Seal all piping penetrations to prevent air and water leakage.

**NOTE:** Factory-installed water valves and piping are bronze, brass, and copper. Dissimilar metals within the plumbing system can cause galvanic corrosion. To avoid corrosion, provide proper dielectric fittings as well as appropriate water treatment.

**Figure 36: Hot Water Heat Section (Shown with Factory Valve and Piping)**

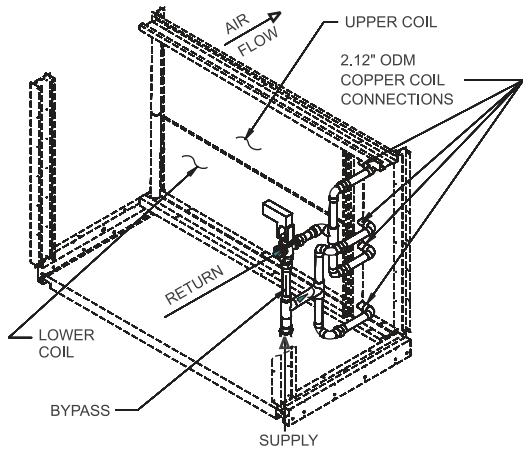

**Figure 38: Steam Heat Section (Shown with Factory Valve and Piping)**

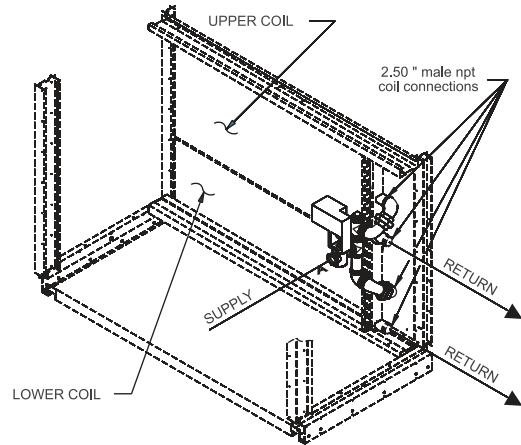

**Figure 37: Hot Water Valve Package**

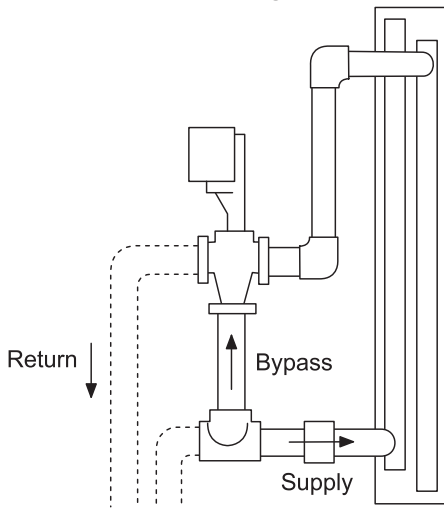

**Steam Coil Piping**

Steam coils are provided without valves for field piping, or piped with two-way valves and actuator motors.

The steam heat coil is pitched at 1/8" (3 mm) per foot (305 mm) to provide positive condensate removal. When no factory piping or valve is included, the coil connections are 2.5" male NPT iron pipe.

With the factory piping and valve package, the field supply connection is the same NPT size as the valve with female threading (see Figure 39).

Refer to the certified drawings for the recommended piping entrance locations. All piping penetrations must be sealed to prevent air and water leakage.

**NOTE:** The valve actuator spring returns to a stem up position upon power failure. This allows full flow through the coil.

**Steam Piping Recommendations**

1. Be certain that adequate piping flexibility is provided. Stresses resulting from expansion of closely coupled piping and coil arrangement can cause serious damage.
2. Do not reduce pipe size at the coil return connection. Carry return connection size through the dirt pocket, making the reduction at the branch leading to the trap.
3. Install vacuum breakers on all applications to prevent retaining condensate in the coil. Generally, the vacuum breaker is to be connected between the coil inlet and the return main. However, if the system has a flooded return main, the vacuum breaker to the atmosphere; the trap design should allow venting of the large quantities of air.
4. Do not drain steam mains or takeoffs through coils. Drain mains ahead of coils through a steam trap to the return line.
5. Do not attempt to lift condensate.
6. Pitch all supply and return steam piping down a minimum of 1" (25 mm) per 10 feet (3 m) of direction of flow.

**Steam Trap Recommendations**

1. Size traps in accordance with manufacturers' recommendations. Be certain that the required pressure differential will always be available. Do not undersize.
2. Float and thermostatic or bucket traps are recommended for low pressure steam. Use bucket traps on systems with on/off control only.
3. Locate traps at least 12" (305 mm) below the coil return connection.
4. Always install strainers as close as possible to the inlet side of the trap.
5. A single tap may generally be used for coils piped in parallel, but an individual trap for each coil is preferred.

### Steam Coil Freeze Conditions

If the air entering the steam coil is below 35°F (2°C), note the following recommendations:

1. Supply 5 psi (34.5 kPa) steam to coils at all times.
2. Modulating valves are not recommended. Control should be by means of face and bypass dampers.
3. As additional protection against freeze-up, install the tap sufficiently far below the coil to provide an adequate hydrostatic head to ensure removal of condensate during an interruption on the steam pressure. Estimate 3 ft. (914 mm) for each 1 psi (7 kPa) of trap differential required.
4. If the unit is to be operated in environments with possible freezing temperatures, an optional freeze-stat is recommended. See [Freeze Protection on page 84](#) for additional information.

**Figure 39: Steam Valve Package**

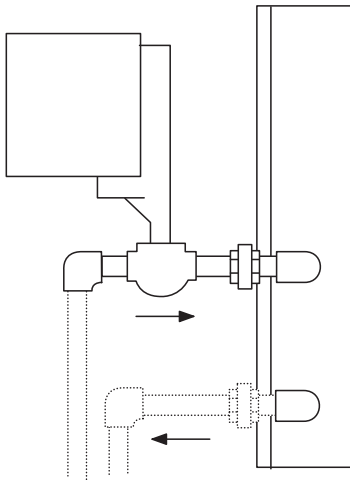

### Damper Assemblies

The optional damper assemblies described in this section normally are ordered with factory-installed actuators and linkages. The following sections describe operation and linkage adjustment of the factory-installed option.

### Economizer Dampers

Outside air intake is provided on both sides of the unit, and the return air path is at the center of the damper set. As the single actuator modulates the outside air dampers open, the return air dampers close. Exhaust air exits the unit through the gravity relief dampers provided at the end of the economizer section.

The damper is set so that the crank arm moves through a 90-degree angle to bring the economizer dampers from full open to full close (see [Figure 40](#)). Access to the actuator and linkage is from the filler section. Mechanical stops are placed in the crank arm mounting bracket. Do not remove stops. Driving the crank arm past the stops results in damage to the linkage or damper. The unit ships with a shipping bolt securing the linkage crank arm. Remove shipping bolt before use.

**NOTE:** For good airflow control, adjust linkages so damper blades do not open beyond 70 degrees. Opening a damper blade beyond 70 degrees has little effect on its airflow.

Do not “overclose” low leak damper blades. The edge seal should just lightly contact the adjoining blade. The blades will lock up if they are closed so far the seal goes over center.

**Figure 40: Damper Adjustment**

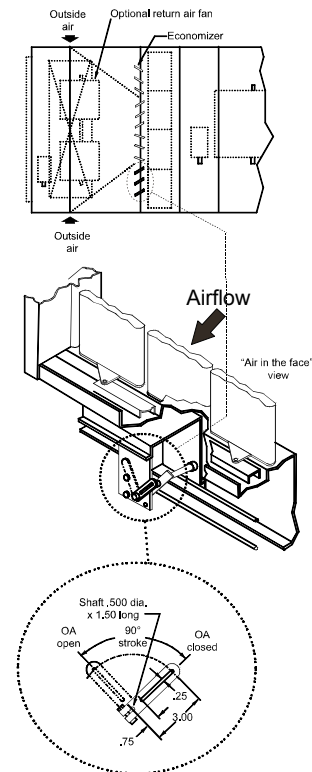

**Intake Hood Damper (0% to 100% outside air)**

Units requiring 100% outside air are provided with a rain hood and dampers that can be controlled by a single actuator. The actuator provides two-position control for opening the dampers fully during unit operation and closing the dampers during the off cycle. No unit mounted exhaust dampers are provided.

**Intake Hood Damper (0% to 30% outside air)**

These dampers are intended to remain at a fixed position during unit operation, providing fresh air quantities from 0 to 30% of the total system airflow, depending on the damper setting. This setting is made at the linkage rod on units with manually adjustable linkages.

On units provided with MicroTech controls, the damper position may be set at the controller keypad. During unit operation, the two-position actuator drives the damper to the position set on the keypad. During the off cycle, the damper is automatically closed.

No unit-mounted exhaust dampers are provided with this option.

**Figure 41: Damper Linkage Bar Typical for All Sizes**

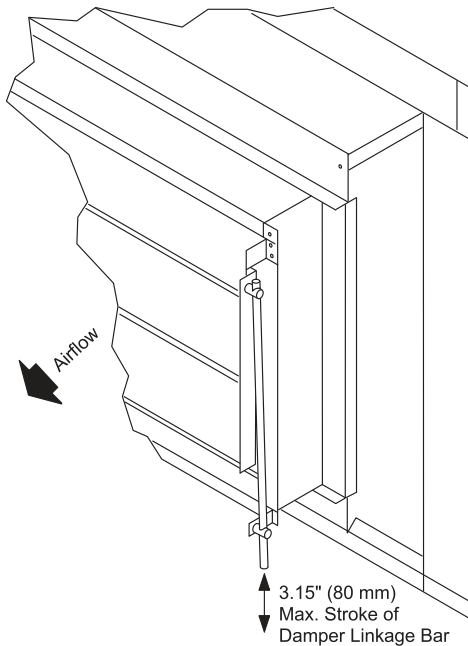

**Figure 42: Intake Hood Damper Adjustment**

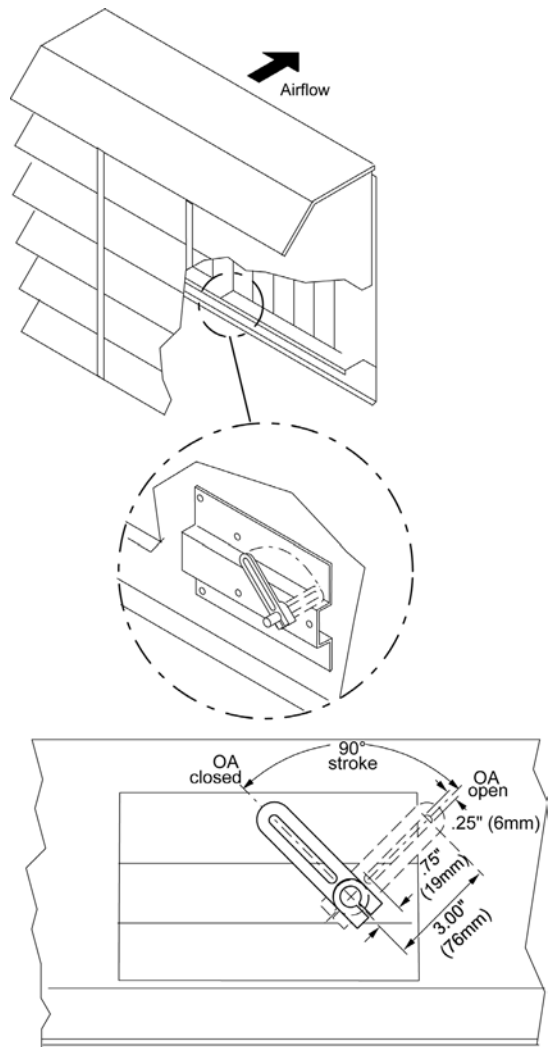

## HEPA Holding Frame, Filter, and Prefilter Installation

These instructions are for installing AAF HEPA filters (11-1/2" depth) into AAF HEPA Holding Frames.

Please read the entire installation instructions before beginning the installation process.

Install filters into the HEPA Holding Frames only after the frames have been securely installed into existing ductwork or housing. Frames should be bolted or pop riveted together into the permanent structure through the pre-drilled holes around the outside perimeter of the frames. Frames should be sufficiently caulked and sealed after completing installation to prevent any air bypass or leakage.

### Required tools for filter installation:

- T-handle Hex key, size 5/32"

### Framing Components Required:

- AAF HEPA Holding Frames
  - P/N 910111491 & 910111674
- Leg Extensions, 4 per frame (A)
  - P/N 910111494
- Latches, 4 per frame
  - P/N 910111493 (B) (without prefilters)
  - P/N 910123164 (C) (with prefilters)
- Prefilter Holding Frames (when prefilters are ordered)
  - P/N 910123166 & 910123168
- Prefilter Latches (when prefilters are ordered)
  - P/N 111048304 & 111048305

**Figure 43: Leg Extensions and Latches without Prefilters**

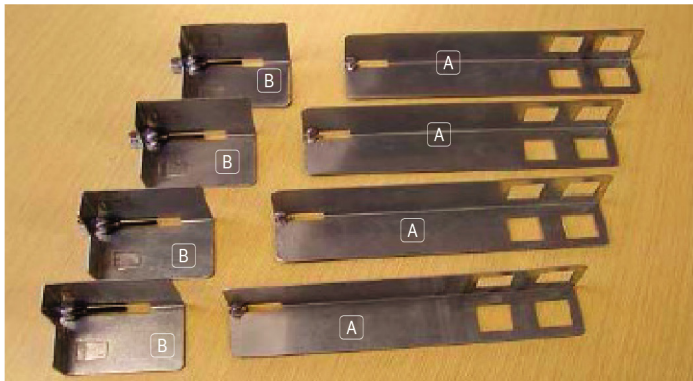

**Figure 44: Leg Extensions and Latches with Prefilters**



## AAF HEPA Filters without Prefilters

1. At the inside corner of each frame are 4 tabs, 2 per side. Place a leg extension over the 4 tabs as shown in [Figure 45](#), then pull back on the leg extension locking it into place ([Figure 46](#)).

Repeat Step 1 with each of the 4 corners. The frame with leg extensions should look like [Figure 47](#).

**Figure 45: Place Leg Extension over the Frame Tabs**

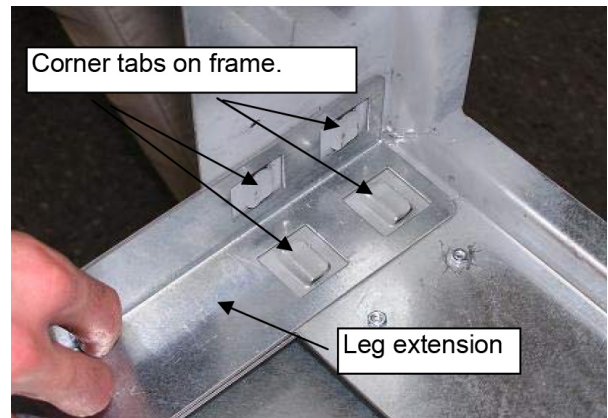

**Figure 46: Pull Back to Lock the Leg Extension into Place**

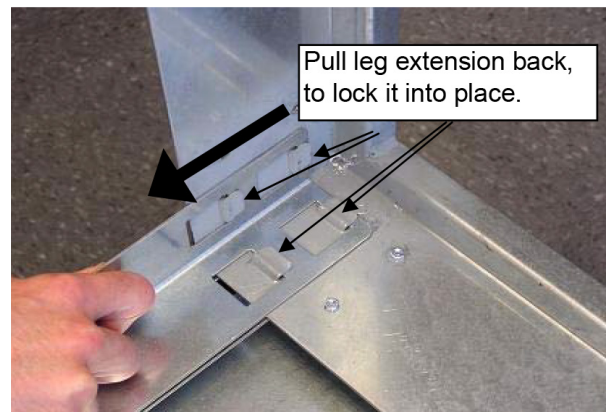



2. Insert the HEPA filter into the HEPA Holding Frame. The HEPA should be installed with the gasket side of the filter facing the frame. Insert the filter as far into the frame as possible, so that the gasket material is contacting the frame. See [Figure 48](#).

The filter should now be resting inside of the holding frame. When installing the filters into a frame bank of multiple frames, install the lower filters first so that the upper filters can rest on the lower filters ([Figure 50](#)).

3. Place a latch so that it overlaps the leg extension, as shown in [Figure 51](#). Align the latches' cap screw with the threaded coupling on the end of the leg extension and tighten using the hex key. Tighten the cap screw until there is an approximately 1/4" gap between the latch and the leg extension coupling as shown in [Figure 52](#). Repeat this step with all 4 corners.

**Figure 47: Frame with Leg Extensions Installed**



**Figure 48: Insert HEPA Filter into Frame, until the Gasket Comes in Contact with the Holding Frame**

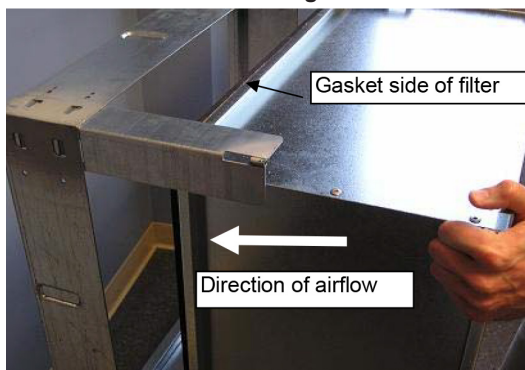

**Figure 49: Insert HEPA Filter until Gasket Material Contacts Frame**

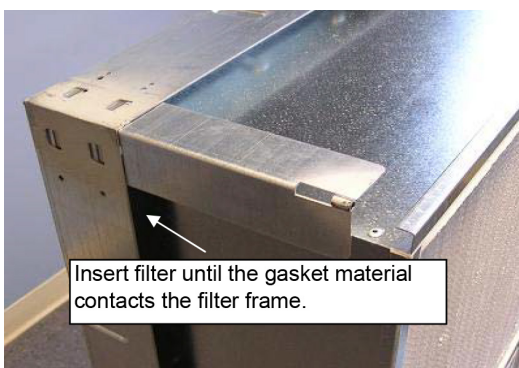

**Figure 50: Filter Placed Inside of Frame**



**Figure 51: Latch Overlapping Leg Extension**

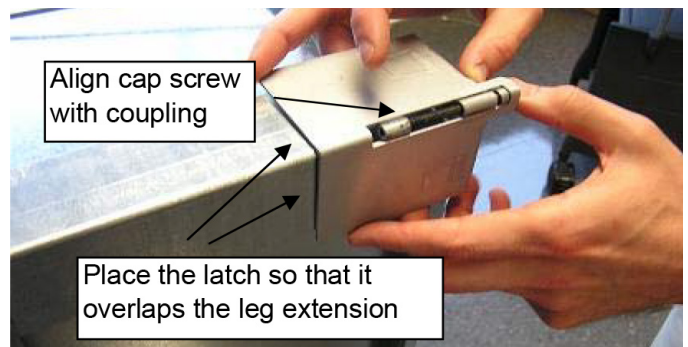

**Figure 52: Tighten Cap Screw to 1/4" of the Coupling**



- Once all four corner latches have been tightened within 1/4" of the leg extension coupling, complete the installation by tightening each corner until the latch and leg extension coupling meet. This is illustrated in [Figure 53](#).

Once all four corners have been tightened the filter should now be properly seated and sealed.

Repeat the process with all remaining filters working from the bottom to the top.

**Figure 53: Tighten until Latch and Coupling Meet**

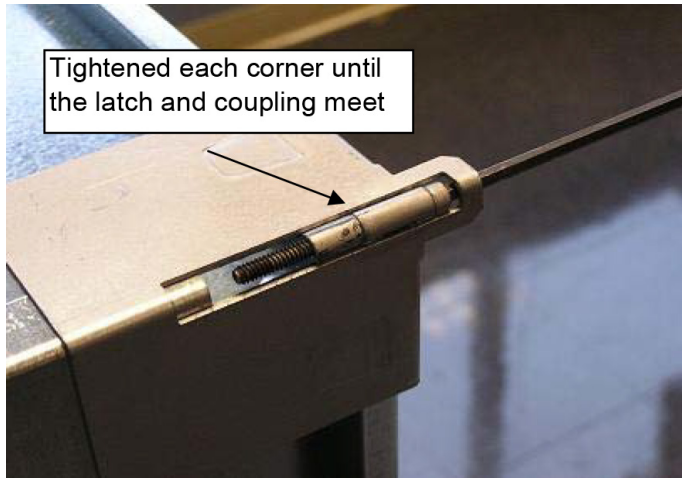

**Figure 54: Properly Installed Filter Inside of the Frame**



## AAF HEPA Filters with Prefilters

Follow steps 1-2 as directed beginning on [page 40](#), then continue to the step below.

- The prefilter holding frame should be placed directly in front of the HEPA filter as shown in [Figure 55](#).

**Figure 55: Positioning of the Prefilter Frame**



- Place a latch so that the 2 tabs of the latch overlap the prefilter frame on each side of the corner. Slide the latch inside of the leg extension and align the latches' cap screw with the threaded coupling on the end of the leg extension and tighten using the hex key. See [Figure 56](#).

Tighten the cap screw until there is an approximately 1/4" gap between the latch and the leg extension coupling as shown in [Figure 57](#). Repeat this step with all 4 corners.

- Once all four corner latches have been tightened within 1/4" of the leg extension coupling, tighten each corner until the latch and leg extension coupling meet. This is shown in [Figure 58](#).

**Figure 56: Latch Positioning for Prefilter Frame**

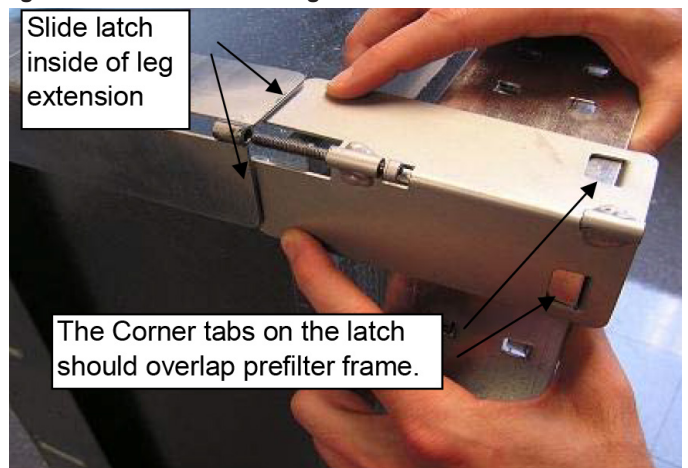

**Figure 57: Tighten Cap Screw to 1/4" of the Coupling**

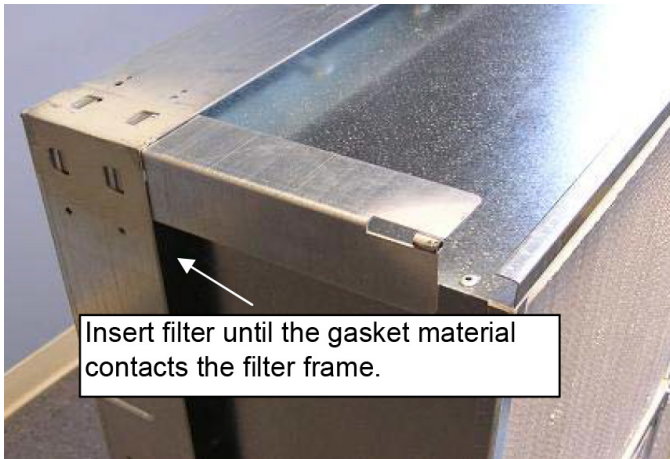

**Figure 58: Tighten until Latch and Coupling Meet**

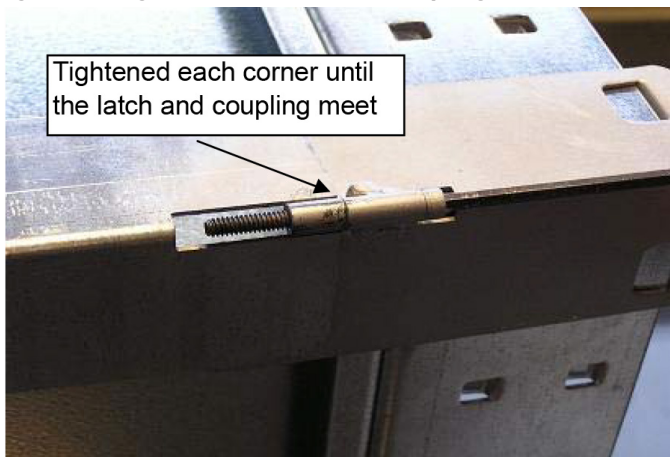

Once all four corners have been tightened the HEPA filter should now be properly seated and sealed.

Repeat the process with all remaining filters working from the bottom to the top.

**Figure 59: Properly Installed HEPA Filter**



4. To complete the installation, add the appropriate prefilter latches to the prefilter holding frame. Once latches are installed, place the prefilter in the frame, secure with the latches and the installation is complete.
5. Repeat with all remaining prefilters and frames.

**Figure 60: Installation of Prefilter into Frame**



**Figure 61: Completed Assembly**



## Cabinet Weather Protection

**CAUTION**

Transportation, rigging, or maintenance can damage the unit's weather seal. Periodically inspect the unit for leakage. Standing moisture can promote microbial growth, disease, or damage to the equipment and building.

This unit ships from the factory with fully gasketed access doors and cabinet caulking to provide weather resistant operation. After the unit is set in place, inspect all door gaskets for shipping damage and replace if necessary.

Protect the unit from overhead runoff from overhangs or other such structures.

Re-caulk field assembled options such as external piping or vestibules per the installation instructions provided with the option.

## Installing Ductwork

**WARNING**

Mold can cause personal injury. Materials such as gypsum wallboard can promote mold growth when damp. Such materials must be protected from moisture that can enter units during maintenance or normal operation.

**NOTICE**

Installer must provide access in the ductwork for plenum-mounted controls. Once duct work is installed in units with side discharge, access to plenum-mounted components is difficult.

On bottom-supply/bottom-return units, if a Daikin Applied roof curb is not used, installing contractor should make an airtight connection by attaching field fabricated duct collars to the bottom surface of either the roof curb's duct flange or the unit's duct opening. Do not support the total weight of the duct work from the unit or these duct flanges. See [Figure 62](#).

Units with optional back return, side discharge, or end discharge (on RFS units) all have duct collars provided. To expose the discharge duct collars on a side discharge unit, remove the plenum section access door and the door gasketing.

Use flexible connections between the unit and ductwork to avoid transmission of vibration from the unit to the structure.

To minimize losses and sound transmission, design duct work per ASHRAE and SMACNA recommendations.

Where return air ducts are not required, connect a sound absorbing T or L section to the unit return to reduce noise transmission to the occupied space.

Ductwork exposed to outdoor conditions must be built in accordance with ASHRAE and SMACNA recommendations and local building codes.

**Figure 62: Installing Duct Work**

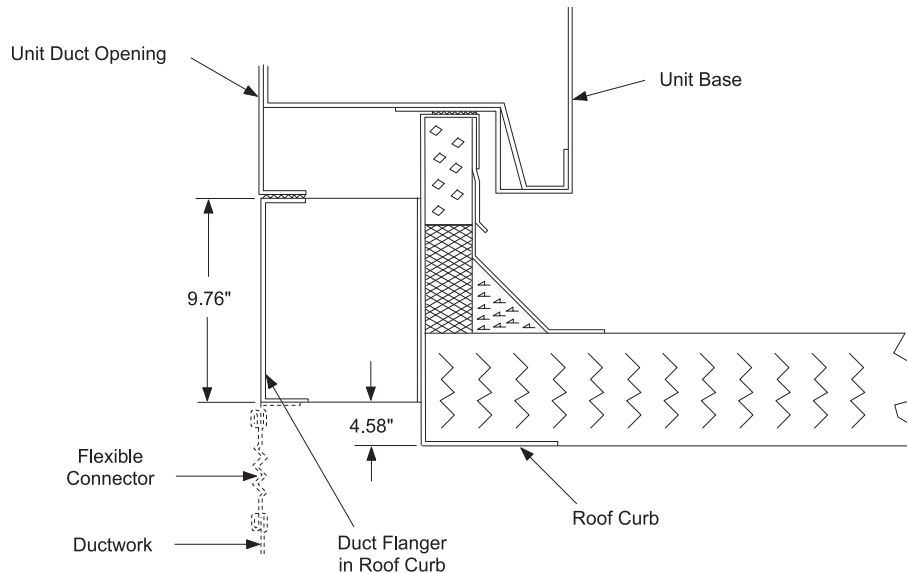

## Installing Duct Static Pressure Sensor Taps

For all VAV units, duct static pressure taps must be field installed and connected to the pressure sensors in the unit. Sensor SPS1 is standard; additional sensor SPS2 is optional. These sensors are located in the main control panel (see [Control Panel on page 8](#)).

Carefully locate and install the duct static pressure sensing tap. Improperly locating or installing the sensing tap causes unsatisfactory operation of the entire variable air volume system. Below are pressure tap location and installation recommendations. The installation must comply with local code requirements

1. Install a tee fitting with a leak-tight removable cap in each tube near the sensor fitting. This facilitates connecting a manometer or pressure gauge if testing is required.
2. Use different colored tubing for the duct pressure (HI) and reference pressure (LO) taps, or tag the tubes. Daikin Applied recommends 3/16" I.D. plastic tubing.
3. Locate the duct pressure (HI) tap near the end of a long duct to ensure that all terminal box take-offs along the run have adequate static pressure.
4. Locate the duct tap in a non-turbulent flow area of the duct. Keep it several duct diameters away from take-off points, bends, neckdowns, attenuators, vanes, or other irregularities.
5. Use a static pressure tip (Dwyer A302 or equivalent) or the bare end of the plastic tubing for the duct tap. (If the duct is lined inside, use a static pressure tip device.)
6. Install the duct tap so that it senses only static pressure (not velocity pressure). If a bare tube end is used, it must be smooth, square (not cut at an angle) and perpendicular to the airstream (see [Figure 64](#)).
7. Locate the reference pressure (LO) tap somewhere near the duct pressure tap within the building (see [Figure 63](#)). If the reference tap is not connected to the sensor, unsatisfactory operation will result.
8. Route the tubes between the curb and the supply duct, and feed them into the unit through the knockout in the bottom of the control panel (see [Figure 63](#)). Connect the tubes to appropriate barbed fittings in the control panel. (Fittings are sized to accept 3/16" I.D. plastic tubing.)

Figure 63: Static Pressure Tubing Entrance Location

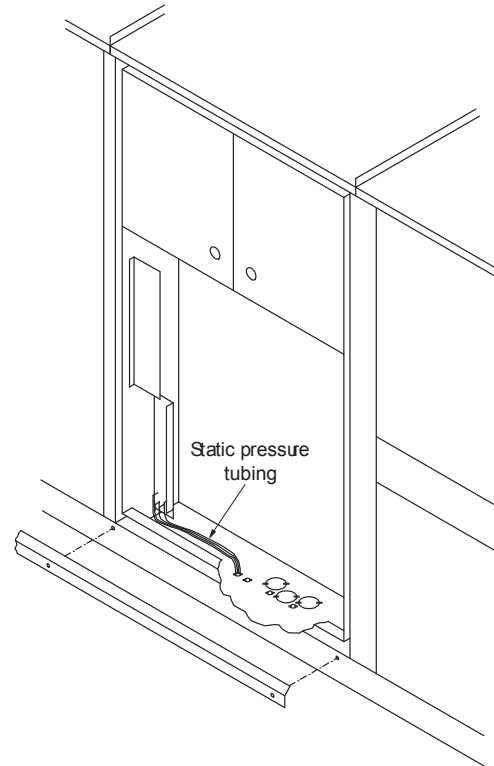
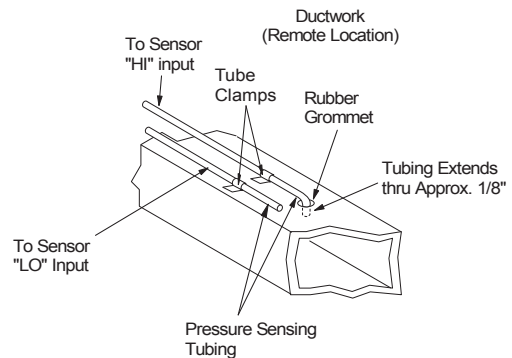
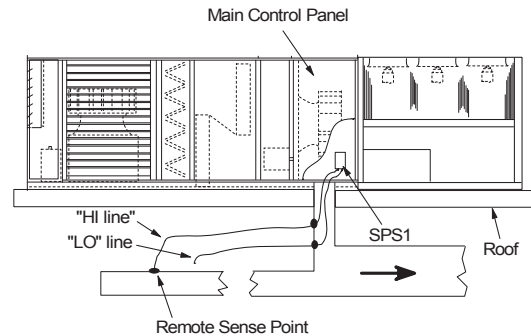

Figure 64: Pressure Sensing Tubing Installation



## Installing Building Static Pressure Sensor Taps

### CAUTION

Fragile sensor fittings. If you must remove tubing from a pressure sensor fitting, use care. Do not use excessive force or wrench the tubing back and forth to remove or the fitting can break off and damage sensor.

If a unit has direct building static pressure control capability, you must field install and connect static pressure taps to pressure sensor SPS2 in the unit. This sensor is located at the bottom of the main control panel next to terminal block TB2 (see [Control Locations on page 7](#) of this manual).

Carefully locate and install the two static pressure sensing taps. Improper location or installation of the sensor taps causes unsatisfactory operation. Below are pressure tap location and installation recommendations for both building envelope and lab, or “space within a space” pressure control applications. The installation must comply with local code requirements.

### **Building Pressurization Applications**

1. Install a tee fitting with a leak-tight removable cap in each tube near the sensor fitting. This facilitates connecting a manometer or pressure gauge if testing is required.
2. Locate the building pressure (HI) tap in the area that requires the closest control. Typically, this is a ground level floor that has doors to the outside.
3. Locate the building tap so it is not influenced by any source of moving air (velocity pressure). These sources may include air diffusers or outside doors.
4. Route the building tap tube between the curb and the supply duct and feed it into the unit through the knockout in the bottom of the control panel (see [Figure 63](#)). Connect the tube to the ¼-inch HI fitting for sensor SPS2.
5. Locate the reference pressure (LO) tap on the roof. Keep it away from the condenser fans, walls, or anything else that may cause air turbulence. Mount it high enough above the roof so it is not affected by snow. Not connecting the reference tap to the sensor results in unsatisfactory operation.
6. Use an outdoor static pressure tip (Dwyer A306 or equivalent) to minimize the adverse effects of wind. Place some type of screen over the sensor to keep out insects. Loosely packed cotton works well.
7. Route the outdoor tap tube out of the main control panel through a small field-cut opening in the edge of the control wiring raceway cover (see [Figure 63](#)). Cut this “mouse hole” in the vertical portion of the edge. Seal the penetration to prevent water from entering. Connect tube to the ¼" LO fitting for sensor SPS2.

### **Lab Pressurization Applications**

1. Install a “T” fitting with a leak-tight removable cap in each tube near the sensor fitting. This facilitates connecting a manometer or pressure gauge if testing is required.
2. Use different colored tubing for the controlled space pressure (HI) and reference pressure (LO) taps, or tag the tubes.
3. Regardless whether the controlled space is positive or negative with respect to its reference, locate the HI pressure tap in the controlled space. (The set point can be set between -0.2 and 0.2" w.c.)
4. Locate the reference pressure (LO) tap in the area surrounding the controlled space. Not locating the reference tap to the sensor results in unsatisfactory operation.
5. Locate both taps so they are not influenced by any source of moving air (velocity pressure). These sources may include air diffusers or doors between the high and low pressure areas.
6. Route the building tap tube between the curb and the supply duct and feed it into the unit through the knockout in the bottom of the control panel (see [Figure 63](#)).
7. Connect the tube to the ¼" HI fitting for sensor SPS2.

## Field Power Wiring

Wiring must comply with all applicable codes and ordinances or in the absence of local codes, with the National Electrical Code ANSI/NFPA 70 and/or Canadian Electrical Code CSA C22.1. The warranty is voided if wiring is not in accordance with these specifications. An open fuse, tripped circuit breaker, or Manual Motor Protector (MMP) indicates a short, ground, or overload. Before replacing a fuse, circuit breaker, MMP, or restarting a compressor or fan motor, identify the trouble and correct.

According to the [National Electrical Code](#), a disconnecting means shall be located within sight of and readily accessible from the air conditioning equipment. The unit can be ordered with an optional factory mounted disconnect switch. This switch is not fused. Power leads must be over-current protected at the point of distribution. The maximum allowable overcurrent protection (MROPD) appears on the unit nameplate.

## All RPS, RFS, and RDT Units

### **⚠ DANGER**

Hazardous voltage. Can cause severe injury or death. Disconnect electric power before servicing equipment. More than one disconnect may be required to de-energize the unit.

### **⚠ CAUTION**

Wires are located in base rail. Move wires before drilling hole through base rail.

All units are provided with internal power wiring for single or dual point power connection. The power block or an optional disconnect switch is located within the main control panel. Field power leads are brought into the unit through 3" knockouts in the bottom of the main control panel. Refer to the unit nameplate to determine the number of power connections. See [Figure 65](#) and [Table 17](#) on page 49.

If the unit has a factory mounted disconnect switch, generally the switch must be turned off to open the main control panel door. However, the door can be opened without disconnecting power by following the procedure covered by the [Through-the-door Disconnect](#) on page 134. If this is done, use caution since power is not removed from the unit or the controller.

**NOTE:** To wire entry points, refer to certified drawings for dimensions.

The preferred entrance for power cables is through the bottom knockouts provided on the unit. If side entrance is the only option, a drilling location is provided.

The drilling dimensions must be followed exactly to prevent damage to the control panel. The dimensions provided are the only possible point of side entrance for the power cables.

**Figure 65: RPS/RDT and RFS Power Wiring Connections**

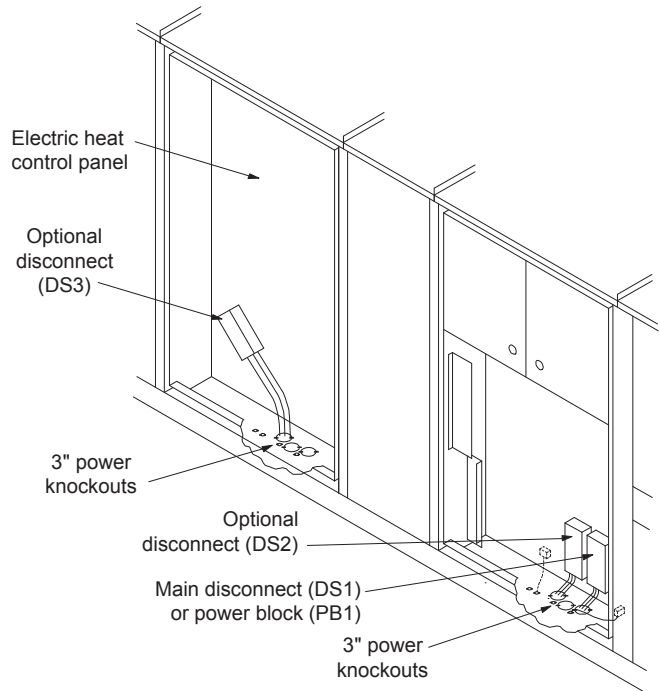

**Figure 66: Optional Side Power Wiring Entrance**

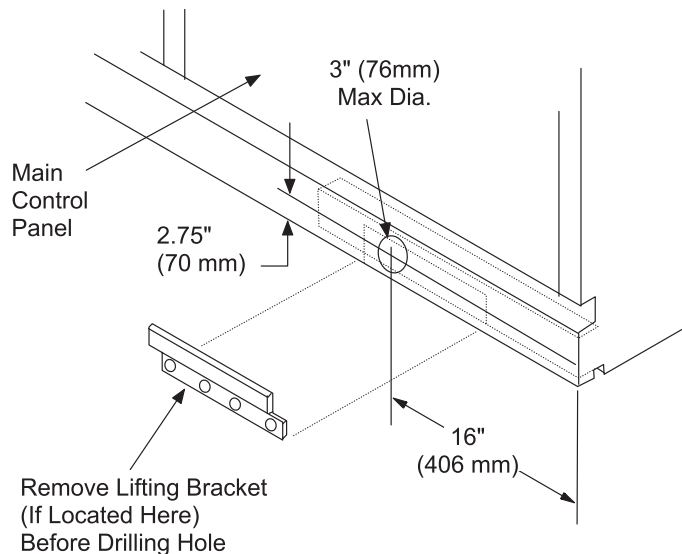





**All Units**

**⚠ DANGER**

Provide proper line voltage and phase balance. Improper line voltage or excessive phase imbalance constitutes product abuse. It can cause severe damage to the unit's electrical components.

The minimum circuit ampacity (wire sizing amps) is shown on the unit nameplate. Refer to [Table 17](#) for the recommended number of power wires.

Copper wire is required for all conductors. Size wires in accordance with the ampacity tables in Article 310 of the [National Electrical Code](#). If long wires are required, it may be necessary to increase the wire size to prevent excessive voltage drop. Wires should be sized for a maximum of 3% voltage drop. Supply voltage must not vary by more than 10% of nameplate. Phase voltage imbalance must not exceed 2%. (Calculate the average voltage of the three legs. The leg with voltage deviating the farthest from the average value must not be more than 2% away.) Contact the local power company for correction of improper voltage or phase imbalance.

A ground lug is provided in the control panel for each disconnect or power block. Size grounding conductor in accordance with Table 250-95 of the [National Electrical Code](#).

In compliance with the National Electrical Code, an electrically isolated 115V circuit is provided in the unit to supply the factory mounted service receptacle outlet and optional unit lights. This circuit is powered by a field connected 15A, 115V power supply. Leads are brought into the RFS and RPS units through a 7/8" knockout in the bottom of the main control panel, near the power wire entry point.

**Figure 68: RCS 050D to 140D Power Wiring Connections**

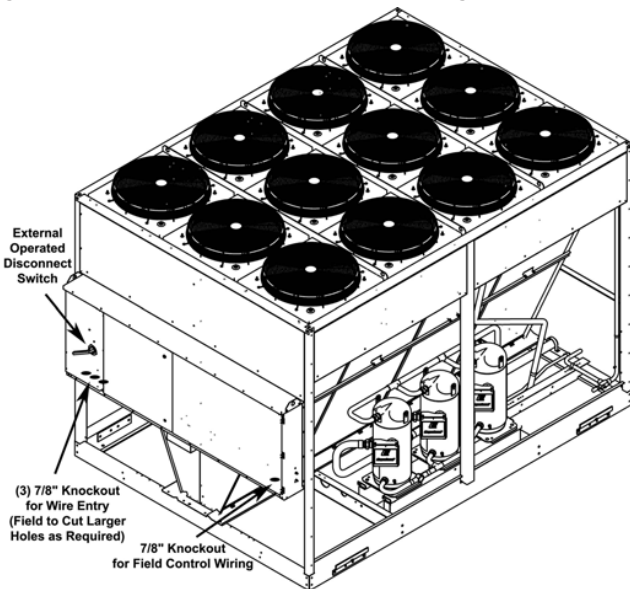

**Table 16: Multiple Point Power Connection Options**

Number of electrical circuits	Disconnect designation	Load	Location (see Figure 9 on page 9)
2	DS2	Supply and return fan motors plus controls	Main control panel
	DS1	Balance of unit	Main control panel
2	DS3	Electric heat	Electric heat control panel
	DS1	Balance of unit	Main control panel
3	DS3	Electric heat	Electric heat control panel
	DS2	Supply and return fan motors plus controls	Main control panel
	DS1	Balance of unit	Main control panel

**Table 17: RPS/RFS/RCS/RDT Recommended Power Wiring**

Ampacity	Number of Power Wires per Phase	Number of Conduits	Wire Gauge	Insulation Rating (0°C)
30	1	1	10	60
40	1	1	8	60
55	1	1	6	60
70	1	1	4	60
85	1	1	3	60
95	1	1	2	60
130	1	1	1	75
150	1	1	1/0	75
175	1	1	2/0	75
200	1	1	3/0	75
230	1	1	4/0	75
255	1	1	250	75
285	1	1	300	75
310	1	1	350	75
335	1	1	400	75
380	1	1	500	75
400	2	2	3/0	75
460	2	2	4/0	75
510	2	2	250	75
570	2	2	300	75
620	2	2	350	75
670	2	2	400	75
760	2	2	500	75
765	3	3	250	75
855	3	3	300	75
930	3	3	350	75

## Field Control Wiring

**DANGER**

Electrical shock hazard. Can cause severe injury or death. Connect only low voltage NEC Class II circuits to terminal blocks TB2 and TB5. Reinstall and secure all protective deadfront panels when the wiring installation is complete.

RoofPak applied rooftop units are available with several control arrangements which may require low voltage field wiring. Detailed descriptions of various field control wiring options and requirements are included in the “Field Wiring” section of [IM 919](#), MicroTech Applied Rooftop Unit Controller. Refer to the unit wiring diagrams for additional installation information.

Wiring must comply with applicable codes and ordinances. The warranty is voided if wiring is not in accordance with these specifications.

### RPS, RDT, and RFS Units

All field control wiring connections are made at the class II terminal block TB2, which is located in the main control panel. Field wiring connections to the 115 volt receptacle and lights are made at terminal block TB7, which is also located in the main control panel. Refer to [Figure 69](#), [Figure 70](#), and [Control Panel on page 8](#). Two 7/8" knockouts are provided for wire entry.

### RFS/RCS Units

The RCS unit receives 115V and 24V control circuit power and a number of control signals from the RFS unit. Two 7/8" knockouts are provided in the right side of the RCS control box.

Interconnecting wiring enters the RFS unit through 7/8" knockouts in the bottom of the main control panel. The interconnecting wiring is connected to TB4 in the RFS unit and TB5 in the RCS unit. Refer to [Figure 52](#). A 7/8" knockout is also available in the end of the unit base as shown in [Figure 50](#).

**NOTE:** If a single conduit containing 24V and 115V wiring is run above the roof line between the RFS and RCS unit, install the 24V wiring as an NEC Class I wiring system.

**Figure 69: RDT, RFS, RPS Field Wiring Connections**

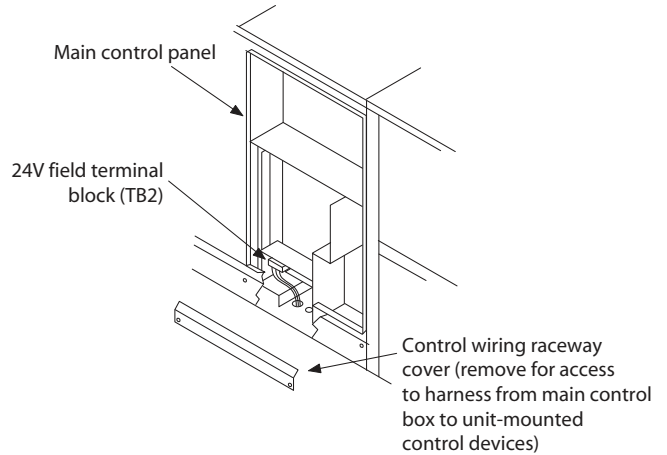

**Figure 70: Control Wiring Raceway**



**Figure 71: RFS and RCS Interconnecting Control Wiring**

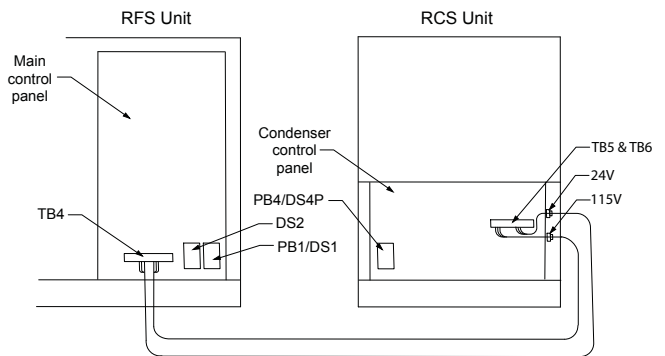

## Preparing Unit for Operation

### Spring Isolated Fans

**WARNING**

Moving machinery hazard. Can cause severe injury or death. Before servicing equipment, disconnect power and lock off. More than one disconnect may be required to de-energize unit.

#### Releasing Spring Mounts

The optional spring-mounted supply and return fans are locked down for shipment. Hold-down fasteners are located at each spring mount. Remove these fasteners before operating the fans. Figure 74 shows a typical spring mount. Note that the 3/8" hold-down bolt securing the fan base to the unit cross channel must be removed.

After removing the hold-down fasteners, rock the fan assembly by hand to check for freedom of movement.

Figure 72: RDT Spring Mount Hold Down Fasteners

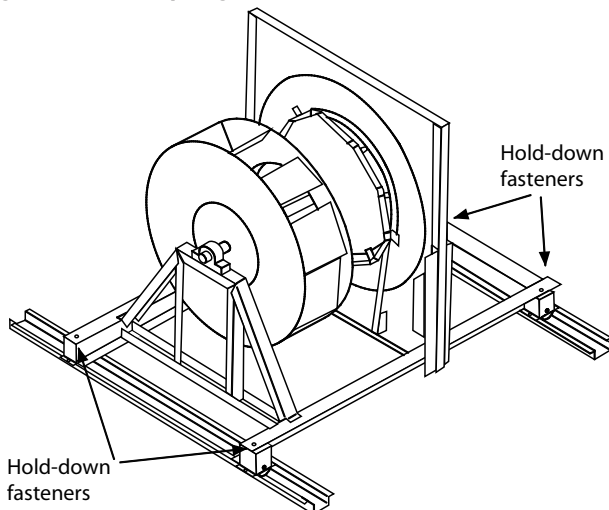
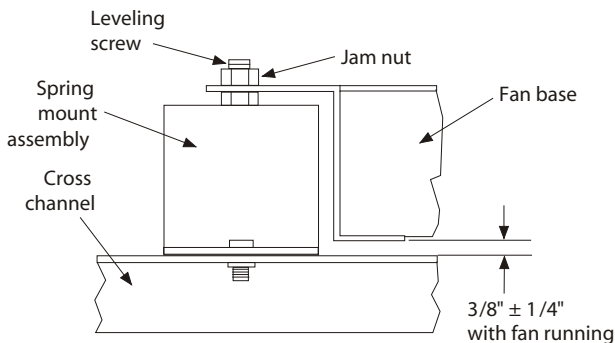

Figure 73: Fan Spring Mount Adjustment



\* Grossly out-of-adjustment thrust restraints can affect this dimension. Recheck after thrust restraints are adjusted.

### Adjusting Spring Mounts

**CAUTION**

Do not use impact tools for field spring mount adjustments as damage to bits or to the bolt slot may occur.

**WARNING**

Moving machinery hazard. Can cause severe injury or death. Start the fans for the first time according to the "Check, Test, and Start Procedures" on page 92. If this is not done, equipment damage, severe personal injury, or death can occur.

To adjust spring mount compression, perform the following:

1. Loosen the 0.625-18 UNF hex nut (Figure 73).
2. Place additional weight on the fan sled frame and use a lever to slightly compress the spring or raise the sled. This will allow the bolt to turn freely.
3. Place one or two drops of oil on the threads if needed.

**NOTE:** The greatest friction that makes adjustment difficult, comes from the surfaces of the top of the upper rebound plate (Figure 73), both sides of the 0.615" washer, and the underside of the sled. If friction is occurring at these points, relieve the weight and oil the friction surfaces.

4. Use a flat blade socket drive bit (1/2" drive handle recommended) and make sure that when adjusting the slotted bolt, that the upper-rebound plate also turns. The slot is located just above the hex nut. This action allows the bolt to push the compression plate (Figure 73) up or down with the least friction occurring between the 0.625" washer and the underside of the channel.

**NOTE:** If the spring compresses to far, lift the sled before turning. If the spring does not compress enough, place weight on the sled corner, forcing it down before turning.

5. Re-adjust the position of the lower-rebound plate so that the sled has at least 3/4" travel and not more than 1.25" of travel.

Figure 74: Spring Mount

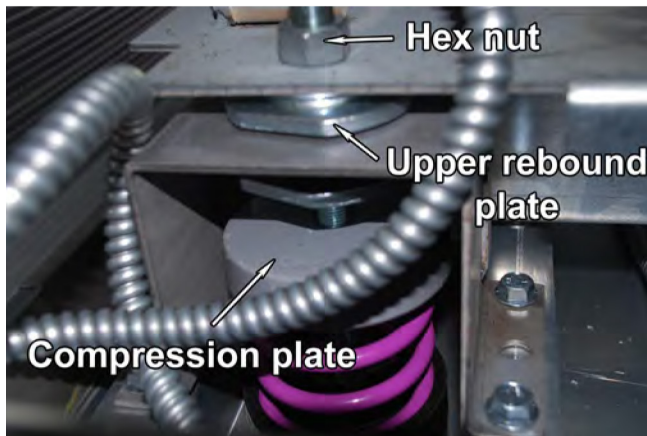

### Relief Damper Tie-Down

Economizer sections with a 30" or 40" return fan have a relief damper that is tied down for shipping. Remove the two brackets and two screws before operation to allow free movement of dampers. Access is from inside the economizer section.

### Adjustment of Seismic Restraints

Spring mounted supply air and return air fans may be ordered with factory installed seismic restraints. Refer to Figure 56. The system consists of four snubbers, one located next to each spring isolator. These snubbers will allow free movement of the fan assemblies during normal operation because normal operation will not cause fan movements that exceed 0.25" (6 mm). However, they will restrain the fan assembly and limit movement to 0.25" (6 mm) in any direction if an abnormal condition were to occur.

The position the fan will assume during normal operation will be determined by actual job site airflow and static pressure. Therefore, for proper operation, the seismic restraints must be field adjusted as part of the normal [Check, Test, and Start on page 107](#) procedure. When the fan is operating in a normal manner there should be no contact between the snubber restrainer angle and the snubber neoprene bumper. However, in a "seismic event," the snubber will limit movement of the spring mounted fan assembly to 0.25" (6 mm) in any direction, thereby helping to prevent the fan from being tossed about and damaged, or causing damage.

When a seismic restraint is properly adjusted and the fan is operating normally, the neoprene center bumper will be centered within the 2" (51 mm) diameter hole in the restrainer angle, and the restrainer angle will be centered vertically between the flanges of the neoprene center bumper. This results in 0.25" (6 mm) clearance in all directions. When the fan is turned off the restrainer angle may come to rest on the neoprene center bumper.

The seismic restraint is adjustable in all directions. Vertical slots in the restrainer angle and horizontal slots in the blower base allow the restrainer angle to be adjusted up and down and back and forth. The neoprene center bumper is mounted on a slotted hole allowing its adjustment in and out.

Removing the neoprene center bumper bolt allows removal, disassembly, and replacement of the neoprene components.

Figure 75: Cross Section of Seismic Restraint

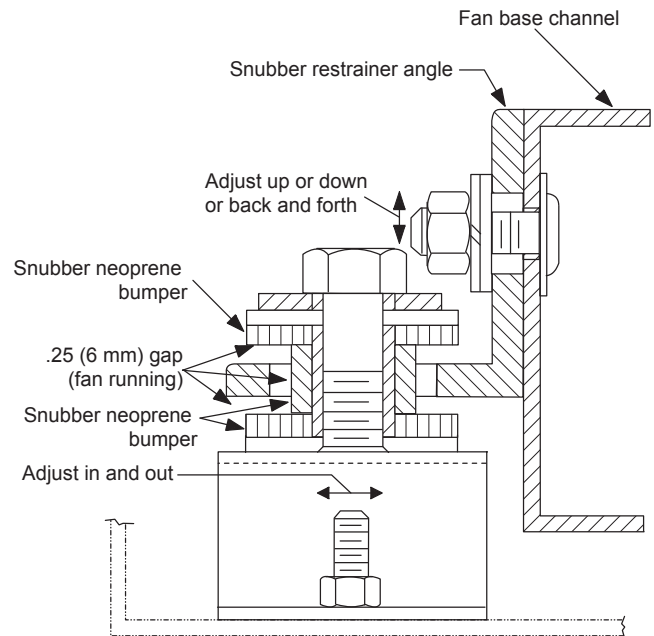

## Adjusting Scroll Dampers

Two sets of scroll dampers are provided in the housing of the twin 15" x 6" supply fan to allow control of air volume to each fan wheel. At the factory, these dampers are fully closed, restricting airflow. If fan paralleling occurs, correct it by loosening the adjustment screw on top of the fan housing (see Figure 76) and slightly lowering the rod until air distribution between the fans is even.

Figure 76: Scroll Damper Adjustment

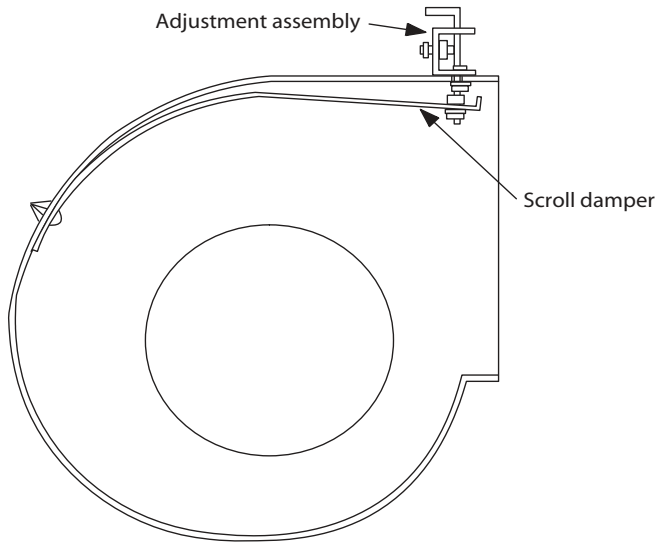

## Adjusting Supply Fan Thrust Restraints

Thrust restraints are provided when housed double-width fans are mounted on springs. After the spring mounts are adjusted for level operation when the fan is running, check the thrust restraints. With the fan off, set the adjustment nuts so the spring is slightly compressed against the angle bolted to the fan housing frame. Refer to Figure 77. When the fan is turned on, the fan moves back to a level position and the thrust restraint springs compress.

Figure 77: Thrust Restraint Adjustment

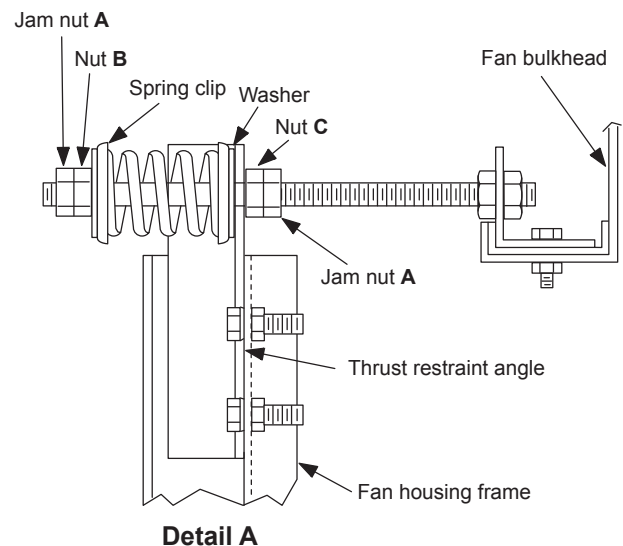
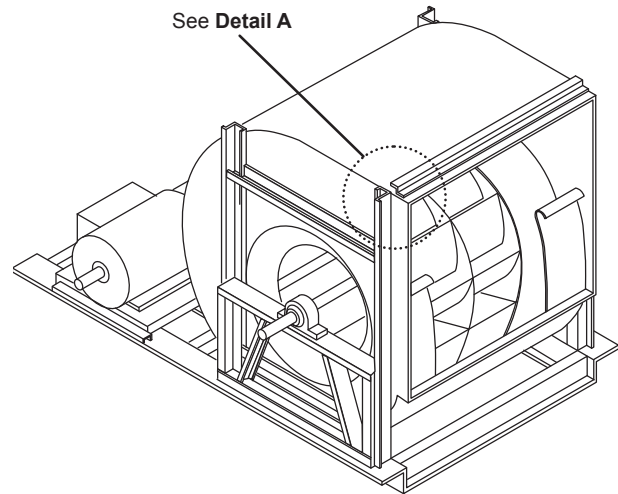

### Thrust restraint adjustment (with fan off)

1. Loosen jam nuts "A".
2. Turn nut "C" until spring cup and washer contact thrust restraint angle.
3. Turn nut "B" until spring is compressed by two turns of nut "B".
4. Tighten jam nuts "A".

The following sequences of operation are for a typical “D” vintage applied rooftop unit equipped with MicroTech, an economizer, mechanical cooling, 3 to 1 turn down burner, variable frequency drives (VFD), a return air fan and an external time clock. These sequences describe the ladder wiring diagram logic in detail; refer to [Wiring Diagrams on page 56](#) as you read them. Note that your unit’s sequences of operation may vary from those described here. Refer to the wiring diagrams supplied with the unit for exact information.

For detailed description of operation information relating to the MicroTech controller’s software, refer to the appropriate operation manual (see [Table 1 on page 3](#)). These manuals describe the various set points, parameters, operating states, and control algorithms that affect rooftop unit operation.

## Power-up

When primary power is connected to the unit, 115 V (ac) power is fed through control circuit transformer T1 and control circuit fuse F1C (line 166, [Figure 79](#)) to compressor crankcase heaters HTR-1, HTR-2, HTR-3 and HTR-4 (lines 836 - 848, [Figure 85](#)).

When system switch S1 (line 203, [Figure 83](#)) is closed, low voltage transformers T2 (line 203, [Figure 83](#)), T3 (line 251, [Figure 83](#)) and T9 (line 802, not shown) energize, and 115 V (ac) power is supplied to the following:

- The supply fan VFD (line 135-137, [Figure 79](#))
- M40A to energize the return fan VFD (line 147-149, [Figure 79](#))
- Heating control panel (line 603, [Figure 84](#))
- Economizer actuator (lines 256-257)
- Transformer T2 supplies 24 V (ac) power to terminals 24V and COM on the main control board MCB (lines 207 and 208). Transformer T2 supplies 24 V (ac) power to the following (see [Figure 78](#) and [Figure 79](#)):
- Switch S7 On-Auto-Off (line 217)
- Enthalpy sensor OAE (line 247)
- External time clock contacts (line 215)
- Airflow interlock switch PC7 (line 228)
- Dirty filter switches PC5 and PC6 (lines 242 and 247, not shown)
- Gas furnace alarm relay R24 (line 225, not shown)
- Freezestat switch FS1 (line 244, hot water or steam heat only, not shown)
- Smoke detectors SD1 and SD2 (line 237)

The time clock, S7 switch, and emergency shutdown terminals (lines 217-222) control fan operation.

**NOTE:** Unit ships with factory installed jumpers between TB2 101 and 105 and between 101 and 106.

## Fan Operation

When the main control board (MCB) commands the supply and return fans to start, the unit enters the Startup operating state. As a result, a 3-minute timer is set, output MCB-BO3 (line 307) energizes, and relay R26 energizes (line 306, not shown).

After the 3-minute timer expires, the unit enters the Recirc operating state. As a result, output MCB-BO1 energizes relay R67 (line 401). This gives a start signal to supply fan drive AFD10 (line 445). Four seconds after MCB-BO1 is energized, output MCB-BO2 energizes relay R68 (line 404). This gives a start signal to return fan drive AFD20 (line 445).

Within 120 seconds after the fans start, the controller expects airflow switch PC7 (line 228) to close and thus energize binary input MCB-BI6. (If MCB-BI6 does not energize, the controller assumes the fans did not start. It then shuts down the unit and generates an alarm.)

During the Recirc operating state, the outside air damper is held closed. The controller does this by energizing output MCB-BO5 (line 318). On VAV units, output MCB-BO12, the VAV box output, is also de-energized (line 309) during the Recirc state.

The supply fan adjustable frequency drive (AFD10) is modulated to maintain the duct static pressure set point. When energized, output MCB-BO14 (line 407) drives AFD10 toward increased capacity; MCB-BO13 (line 405) drives it toward decreased capacity. On VAV units or CAV units equipped with return fan capacity control, the adjustable frequency drive (AFD20) is modulated to maintain an acceptable building static pressure (using either VaneTrol logic or direct measurement of building pressure; see the appropriate OM for more information). When energized, output MCB-BO16 (line 409) drives AFD20 toward increased capacity; MCB-BO15 (line 411) drives them toward decreased capacity.

**NOTE:** If the inverter bypass switch S4 (lines 426 and 430) is in the bypass position, MMP30 and MMP40 (line 132 and 144) protect the fans from excessive current draw. If either the supply or return fan is drawing excessive current, one of the MMPs triggers an auxiliary contacts (line 426) and open the circuit, causing both fans to stop.

## Economizer Operation

Refer to [Figure 84](#). When the outdoor air is suitable for free cooling, the switch in enthalpy sensor OAE is in position “3” (line 248, [Figure 84](#)) energizing analog input AIX5. When AIX5 energizes, the economizer is enabled. (Note: If selected from the keypad, the enthalpy decision can be made based on outdoor temperature. In that condition, if the outdoor air temperature is less than or equal to the changeover set point, the economizer is enabled.) If cooling is required, the economizer dampers (ACT3) are modulated to maintain the discharge air temperature set point. Analog input AIX5 drives the outdoor air dampers toward the open and closed (line 256) position. If the outdoor air dampers are wide open and more cooling is required, the dampers hold their positions and mechanical cooling is activated.

When the outdoor air is not suitable for free cooling, the switch in enthalpy sensor OAE is in position “1,” de-energizing analog input AIX5. (Alternatively, the outdoor air temperature is above the changeover set point plus the economizer changeover differential). When the economizer is disabled, the dampers are held at their minimum position.

## Fixed Speed Compressor Operation

### 4-Compressor/4-Stage Unit

Refer to [Figure 85 on page 70](#) and [Figure 86: RPS 061 Condensing Unit Control \(With Fixed Speed Scroll Compressors\) on page 72](#) as you read this sequence of operation. In this configuration there are four equally sized compressors and two cooling circuits. In the following description, compressor #1 is lead. However, if Auto Lead/Lag Staging is selected on the keypad, the lead compressor is the one in the lead circuit with the least number of run hours.

**NOTE:** Lead lag is not available with the variable speed inverter compressor.

When the unit disconnect is closed, 115 V (ac) power is supplied directly from control transformer T1 to the compressor crankcase heaters, HTR-1, 2, 3, and 4 (lines 836 - 848, 853) and motor protectors MP1, 2, 3, and 4 (lines 836 - 848, 854). This same 115 V (ac) source also goes through:

- System switch, S1 (line 203, [Figure 68 on page 64](#))
- The optional phase voltage monitors, PVM1 and 2 (lines 203, 802, not shown)
- The optional ground fault relays, GFR1 and 2 (lines 203, 802, not shown)

Compressors are staged by 115 V (ac) power supplied to the following:

- Frost protect FP1 to CCB1-BI8 (line 812, not shown)—Optional when no hot gas bypass is ordered on the unit
- Frost protect FP2 to CCB2-BI8 (line 823, not shown)—Optional when no hot gas bypass is ordered on the unit
- HP relay R1 to CCB1-BI7 (lines 812)
- HP relay R2 to CCB2-BI7 (lines 823)
- Compressor contactor status M1 to CCB1-BI9 (line 812)
- Compressor contactor status M2 to CCB2-BI9 (line 823)
- Compressor contactor status M3 to CCB1-BI10 (line 814)

## Cross Circuit Loading

See line 812, [Figure 86](#). During a call for cooling, if HP1 is satisfied, then DO1 closes. If MMP1 and MP1 are satisfied, then M1 compressor contactor is energized to bring on compressor 1 on refrigerant circuit 1 (line 708 - 710, [Figure 81](#)). The M1 auxiliary brings on:

- Required condenser fans (line 854)
- Liquid line drop solenoids (lines 855 and 856)

The drop solenoids are electrically energized by compressor contactor auxiliary contacts. They open when the first compressor turns ON and they close when the last compressor turns OFF.

Compressor 2 (refrigerant circuit 2) is the 2nd stage of cooling and is brought on in the same manner (line 823, [Figure 86](#) and lines 708 - 710, [Figure 81](#)).

Circuit 2 condenser fans and solenoids are controlled in the same manner on lines 861 - 865).

The 3rd stage of cooling is controlled by DO2 (line 814) and brings on compressor 3 if MMP3 and MP3 are satisfied.

The 4th stage of cooling is controlled by DO4 (lines 826) and brings on compressor 3 if MMP3 and MP3 are satisfied.

### Lead Circuit Loading

The loading and unloading process is similar except that both compressors in the lead cooling circuit 1 energize before energizing any compressors in lag circuit 2.

## Heating

### Gas Furnace, Super Modulating Burner (20:1 Turndown)

Refer to [Figure 84 on page 68](#) for a sequence of operation.

**Legend**

ID	Description	Standard location
ACT3, 4	Actuator motor, economizer	Economizer section
ACT5	Actuator motor, discharge isolation damper	Discharge section
ACT6	Actuator motor, return air isolation damper	Return section
ACT7	Actuator motor, heat face/bypass	Coil section, heat
ACT8	Actuator motor, cool face/bypass	Coil section, cool
ACT10, 11	Actuator motor, exhaust dampers	Return section
ACT12	Actuator motor, enthalpy wheel bypass damper	Energy recovery section
AFD10	Adjustable frequency drive, supply fan	AFD/supply fan section
AFD11	Adjustable frequency drive, evap cond fans	Main/RCE control box
AFD20	Adjustable frequency drive, return/exhaust fan	AFD/ret. ex. fan section
AFD60	Adjust freq drive, energy recovery wheel(s)	Energy recovery section
AS	Airflow switch, burner blower	Gas heat box
BM	Burner blower motor	Heat section, gas
C1-8	Power factor capacitors, compressors	Condenser section
C10	Power factor capacitors, supply fan	Supply Fan section
C11	Capacitors, Speedtrol, circuit #1	Condenser bulkhead
C20	Power factor capacitors, return fan	Return section
C21	Capacitors, Speedtrol, circuit #2	Condenser bulkhead
CB10	Circuit breaker, supply fan	Main control box
CB11	Circuit breaker, evaporative condenser fan(s)	Main/Cond control box
CB20	Circuit breaker, return/exhaust fan	Main control box
CB60	Circuit breaker, energy recovery wheel	Main control box
CCB1, 2	Compressor control boards, refrigerant circuits	Main control box
CDS2	Discharge thermostat	VFD compressor
CPC	Circuit board, main, micro controller	Main control box
CPR	Circuit board, expansion, micro controller	Main control box
CS1, 2	Control switches, refrigerant circuits	Main/Cond control box
DAT	Discharge air temperature sensor	Discharge section
DFLH	Design flow left hand sensor	Return section
DFRH	Design flow right hand sensor	Return section
DHL	Duct hi-limit	Main control box
DS1	Disconnect, total unit or cond/heat	Main control box
DS2	Disconnect, SAF/RAF/controls	Main control box
DS3	Disconnect, electric heat	Electric heat box
DS4	Disconnect, condenser (RCS Only)	RCS control box
EAT	Exhaust air temperature sensor	Energy recovery section
EFT	Entering fan air temperature sensor	Supply fan section
EHB1	Staged electric heat board	Main control box
ERB1	Energy recovery board	Main control box
ERM1	Energy recovery wheel motor #1	Energy recovery section
ERM2	Energy recovery wheel motor #2	Energy recovery section
F1A, B	Fuse, control circuit transformer (T1), primary	Main control box
F1C	Fuse, control circuit transformer (T1), secondary	Main control box
F2	Fuse, control circuit transformer (T2), primary	Main control box
F3	Fuse, burner blower motor	Main control box
F2M	Fuses, VFD compressor	Main control box
FB11, 21	Fuseblock, Speedtrol	Main/Cond control box
FB2M	Fuseblock, VFD compressor	Main control panel
FB31-40	Fuseblock, electric heat (top bank)	Electric heat box
FB41-50	Fuseblock, electric heat (bottom bank)	Electric heat box
FB65	Fuseblock, evap cond sump heater	Main/Cond control box

ID	Description	Standard location
FD	Flame detector	Heat section, gas
FLC	Fan limit control	Heat section, gas
FP1, 2	Frost protection, refrigerant circuits	Coil section, cool
FS1, 2	Freezestat control	Coil section, heat/cool
FSG	Flame safeguard	Gas heat box
GFR1, 2	Ground fault relay	Main control box
GFS1, 2	Ground fault sensor	Main control box
GFR4	Ground fault relay, condenser	Condenser control box
GFS4	Ground fault sensor, condenser	Condenser control box
GRD	Ground	All control boxes
GV1	Gas valve, pilot	Heat section, gas
GV2	Gas valve, main/safety	Heat section, gas
GV3	Gas valve, redundant/safety	Heat section, gas
GV4-8	Gas valve, main, hi turn down	Heat section, gas
HL1-10	Hi-limits, pwr, elec heaters (top bank)	Heat section, electric
HL11-20	Hi-limits, pwr, elec heaters (bottom bank)	Heat section, electric
HL22	Hi-limits, gas heat (pre-filters)	Supply fan section
HL23	Hi-limits, gas heat (final filters)	Final filter section
HL31-40	Hi-limits, ctl elec heaters (top bank)	Heat section, electric
HL41-50	Hi-limits, ctl elec heaters (bottom bank)	Heat section, electric
HP1-4	Hi-pressure controls, refrigerant	Main control box
HP5	Hi-pressure controls, gas	Heat section, gas
HS1	Heat switch, electric heat shutdown	Main control box
HS3	Heat switch, electric heat deadfront interlock	Electric heat box
HTR1-6	Crankcase heaters	On compressors
HUM1	Humidstat sensor	Energy recovery section
IT	Ignition transformer	Gas heat box
LAT	Leaving air temperature sensor	Energy recovery section
LP1, 2	Low-pressure controls, refrigerant	Main control box
LP5	Low-pressure control, gas	Heat section, gas
LR10	Line Reactor, supply fan	Inverter bypass box
LR20	Line reactor, return/exhaust fan	Inv. bypass/main cntl box
LR2M	Line reactor, VFD compressor	Condensing section
LS1, 2	Limit switch, low fire, high fire	Gas heat box
LT10-23	Light, cabinet sections	Supply fan section
M1-8	Contactors, compressor	Main/Cond control box
M10	Contactors, supply fan	Main control box
M11-18	Contactors, condenser fans, circuit #1	Main/Cond control box
M20	Contactors, return fan	Main control box
M21-28	Contactors, Condenser fans, circuit #2	Main/Cond control box
M29	Contactors, burner motor	Gas heat box
M30	Contactors, reversing, inverter bypass, supply fan	Inverter bypass box
M31-39	Contactors, electric heat (top bank)	Electric heat box
M40	Contactors, reversing, Inverter Bypass, Return Fan	Inverter bypass box
M41-50	Contactors, electric heat (bottom bank)	Electric heat box
M60	Contactors, energy recovery wheel	Main control box
M64	Contactors, sump pump	Main/Cond control box
M65	Contactors, sump heater	Main/Cond control box
MCB	Microprocessor circuit board	Main control box
MF3, MF4	Cooling fan, VFD compressor panel	VFD compressor panel
MJ	Mechanical Jumper	All control boxes
MMP1-8	Manual motor protector, compressors	Main/Cond control box
MMP10	Manual motor protector, supply fan	Main control box
MMP11-18	Manual motor protector, cond fans, ckt#1	Main/Cond control box
MMP20	Manual motor protector, return fan	Main control box
MMP21-28	Manual motor protector, cond fans, ckt#2	Main/Cond control box



ID	Description	Standard location
MMP30	Manual motor protector, invtr bypass, sup fan	Inverter bypass box
MMP40	Manual motor protector, invtr bypass, ret fan	Inverter bypass box
MMP51, 52, 53	Manual motor protector, exhaust fan(s)	Prop exhaust box
MMP60	Manual motor protector, energy recovery wheel	Main control box
MP1-6	Motor protector, compr #1-6	On compressors
OAE	Outside air enthalpy sensor	Economizer section
OAT	Outside air temperature sensor	Economizer section
OOS	Optical oil sensor	VFD compressor
PB1, 2	Power block, power distribution	Main control box
PB3	Power block, power distribution, electric heat	Electric heat box
PB4	Power block, power distribution, condenser	Condenser control box
PB9, 10	Power block, supply fan	Junction box, split unit
PB11, 12	Power block, power distribution	Main control box
PB19, 20	Power block, return/exhaust fan	Junction box, split unit
PC5	Pressure control, clogged filter	Pre filter section
PC6	Pressure control, clogged final filter	Final filter section
PC7	Pressure control, proof airflow	Supply fan section
PC8	Pressure control, minimum airflow	Coil section, cool
PC13, 23	Pressure control, Fantrol	Condenser section
PM1	Phone modem	Main control box
PS1, 2	Pumpdown switches, refrig circuits	Main/Cond control box
PS3	Pumpdown switch, RFS only	Main control box
PT1, PT2	Discharge pressure transducer	Condenser panel
PVM1, 2	Phase voltage monitor	Main control box
PVM4	Phase voltage monitor, condenser	Condenser control box
R1, 2	Relay, hi pressure reset	Main/Cond control box
R3, 4	Relay, hi pressure delay	Main/Cond control box
R5-8	Relay, safety, cool fail	Main/Cond control box
R9, 10	Relay, compressor lockout	Main/Cond control box
R11, 12	Relay, Speedtrol fan cycling	Main/Cond control box
R20	Relay, Heat, gas/steam/hot water	Gas heat/main cntl box
R21, 22	Relay, heat, gas (hi-turn down)	Gas heat box
R23	Relay, heat, gas & electric	Gas/electric heat box
R24	Relay, heat alarm, gas	Main control box
R25	Relay, heat, gas, start supply fan inverter	Main control box
R26	Relay, isol/exh dampers, open/close	Main control box
R28	Relay, isolation damper, safety	Main control box
R29	Relay, remote fire alarm	Main control box
R30	Relay, cool valve with face bypass	Main control box
R37	Relay, SV2 and CCH (compressor2)	Main control panel
R38	Relay, VFD compressor	VFD compressor panel
R40	Relay, oil level	VFD compressor panel
R45	Relay, UV lights	Main control box
R46, 47	Relay, supply fan inverter, incr/decr	Main control box
R48, 49	Relay, return fan inverter, incr/decr	Main control box
R58,59	Relay, heat wheel inverter, incr/decr	Main control box
R60	Relay, energy recovery wheel, enable	Main control box
R61	Relay, smoke detector, discharge air	Main control box
R62, 63, 65	Relay, use on specials	Main control box
R66	Relay, smoke detector, return air	Main control box
R67	Relay, supply fan, enable	Main control box
R68	Relay, return fan, enable	Main control box
R69	Relay, Inv. bypass VAV box interlock	Main control box
R70-79	Relay, use on specials	Main control box
RAE	Return air enthalpy sensor	Return section
RAT	Return air temperature sensor	Return section
REC1	Receptacle, main box	Main control box
REC2	Receptacle, condenser box	Condenser control box

ID	Description	Standard location
REC3	Receptacle, field power, 115V	Discharge bulkhead
REC10-23	Receptacle, cabinet sections	Cabinet sections
S1	Switch, system ON/OFF	Main control box
S2	Switch, system ON/OFF, condenser unit	Condenser control box
S3	Switch, furnace ON/OFF	Gas heat box
S4	Switch, inverter bypass, ON/OFF	Main control box
S7	Switch, local ON/AUTO/OFF to controller	Main control box
S10-23	Switches, cabinet section lights	Cabinet sections
S40-45	Switches, door interlock, UV lights	Cabinet sections
SC11	Speed control, circuit #1	Condenser bulkhead
SC21	Speed control, circuit #2	Condenser bulkhead
SD1	Smoke detector, supply	Discharge section
SD2	Smoke detector, return	Return section
SPS1, 2	Static pressure sensors, duct/building	Main control box
SR1-3	Sequencing relays, electric heat	Electric heat box
SV1, 2	Solenoid valves, liquid	DX coils
SV9, SV10	Condenser coil splitter solenoid	Condenser section
SV11	Oil injection solenoid	VFD compressor
T1	Transformer, main control (line/115 V (ac)	Main control box
T2	Transformer, control input (115/24 V (ac)	Main control box
T3	Transformer, control output (115/24 V (ac)	Main control box
T4	Transformer, exh damper actuator (115/12 V (dc)	Main control box
T5	Transformer, electric heat	Electric heat box
T6	Transformer, dew point controller (115/24 V (ac)	Main control box
T9	Transformer, refrig circuit 24V	Main control box
T11	Transformer, speedtrol (line/240 V (ac)	Condenser section
TB1	Terminal block, internal	Main control box
TB2	Terminal block, field	Main control box
TB3	Terminal blocks, factory	Main control box
TB4	Terminal block, RFS, field	Main control box
TB5	Terminal block, RCS, field	Condenser control box
TB6	Terminal block, RCS, factory	Condenser control box
TB7	Terminal block, 115V convenience outlet, field	Main control box
TB8	Terminal block, 115V conv outlet, RCS, field	Condenser control box
TB11	Terminal block, heat	Heat control box
TB14	Terminal block, VFD compressor	VFD control panel
TB25, 26, 27, 28	Terminal block, split unit junction box	Junction box, split unit
TB35, TB36	Terminal block, condenser fans	Condenser panel
TC12, 13, 14	Temperature controls, Fantrol	Condenser section
TD1, 2	Time delay, compressor lockout	Main/Cond control box
TD3, 4	Time delay, hi-pressure	Main/Cond control box
TD5-8	Time delay, part winding, compr #1-4	Main control box
TD10	Time delay, hi turn down burner	Gas heat box
TD11, 12	Time delay, low ambient	Main/Cond control box
TR1, 2	Transducer, pressure	Main control box
U1, 2	Unloaders, compressors	On compressors
UV	Ultra-violet light(s)	Coil/discharge section
VFD2	Compressor VFD	VFD control panel
VM1	Valve motor #1, heating	Gas heat box/ heat section
VM5	Valve motor #5, cooling	Coil section, cool
VV1	Vent valve, gas heat	Heat Section, Gas
ZNT1	Zone temp. sensor, setback	Field installed

## General Notes

1. — — - Field wiring
2. ——— Factory wiring
3.  Shielded wire/cable
4. —○— Main control box terminals
5. —□— Auxilliary box terminals
6. —⊙— Field terminals
7. —≪— Plug connector
8. —<sup>200H208</sup>— Wire/harness number
9. —<sup>WN7</sup>□— Wire nut/ID

Figure 78: VAV Fan Power (With SAF and RAF VFDs and Unit Powered Outlet/Light Circuit)

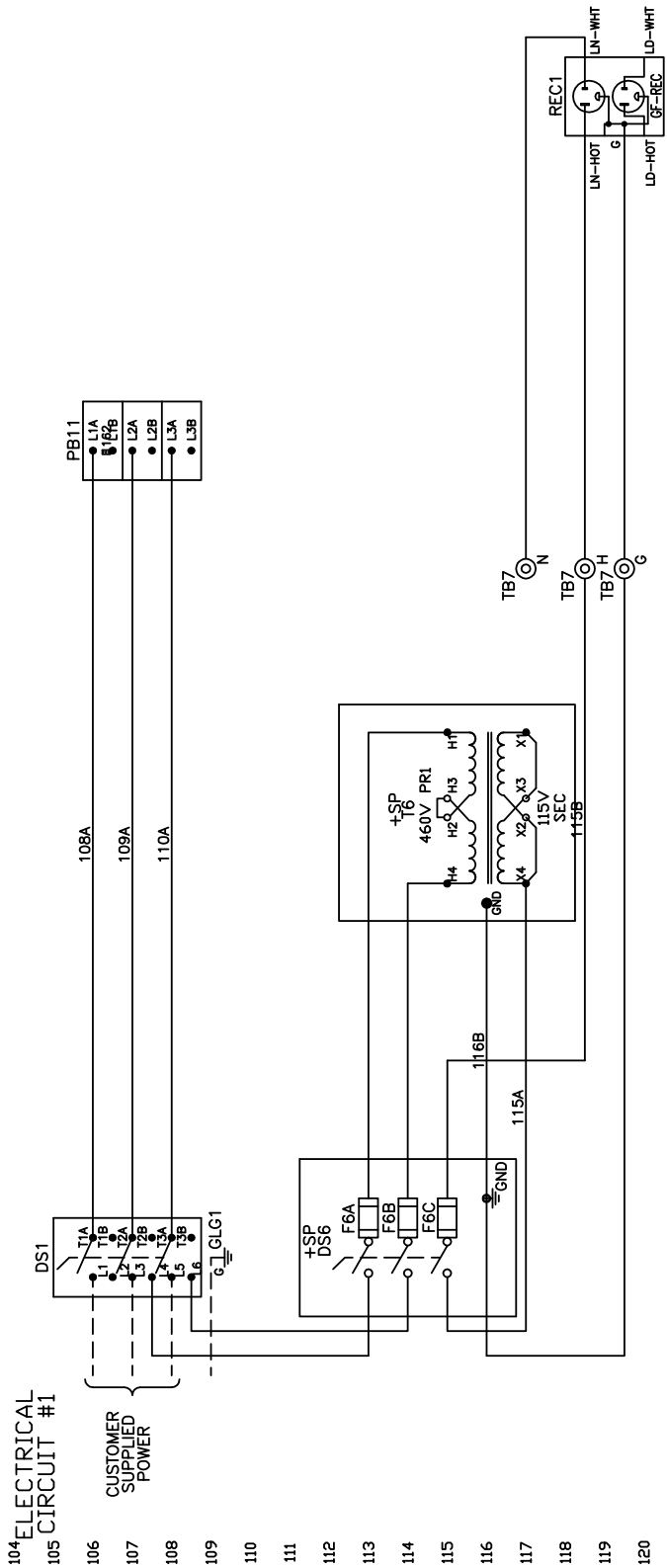
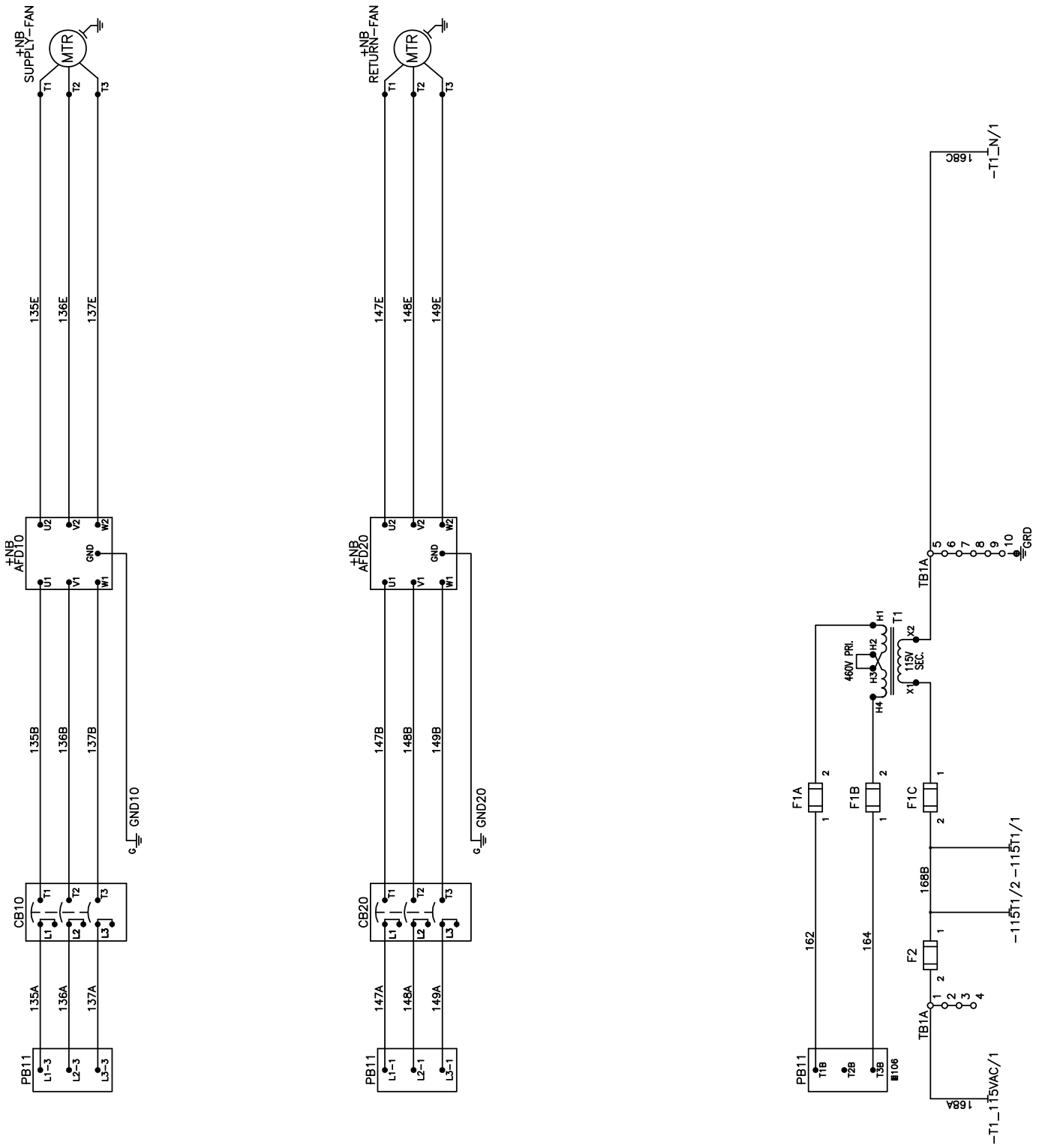
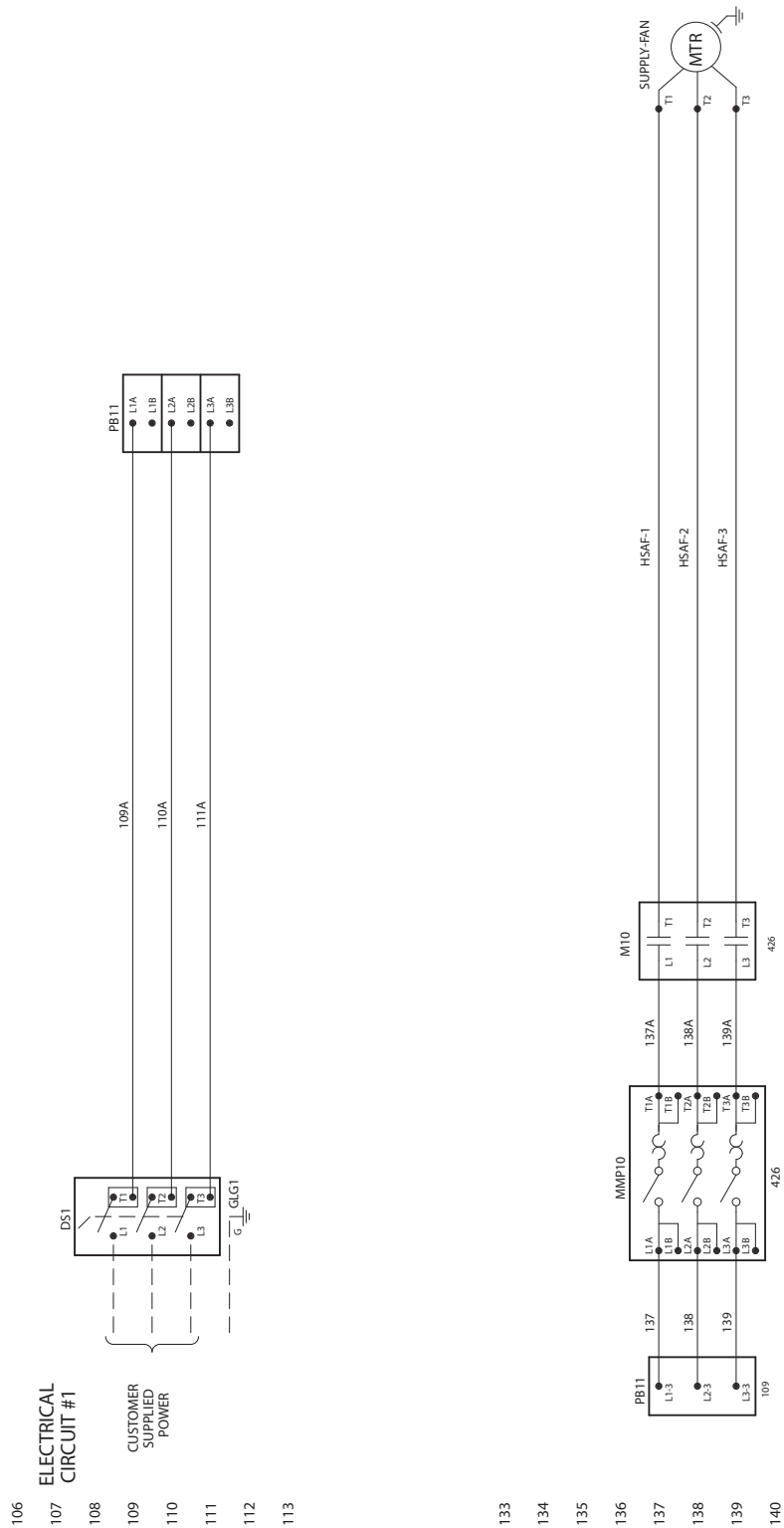

Figure 78 continued: VAV Fan Power (With SAF and RAF VFDs and Unit Powered Outlet/Light Circuit)



134  
135  
136  
137  
138  
139  
140  
141  
142  
143  
144  
145  
146  
147  
148  
149  
150  
151  
152  
153  
154  
155  
156  
157  
158  
159  
160  
161  
162  
163  
164  
165  
166  
167  
168  
169  
170

Figure 79: Constant Volume Fan Power (SAF and RAF)



(Schematic continues on next page.)

106  
107  
108  
109  
110  
111  
112  
113

133  
134  
135  
136  
137  
138  
139  
140  
141

Figure 79 continued: Constant Volume Fan Power (SAF and RAF)

(Schematic continues on the previous page.)

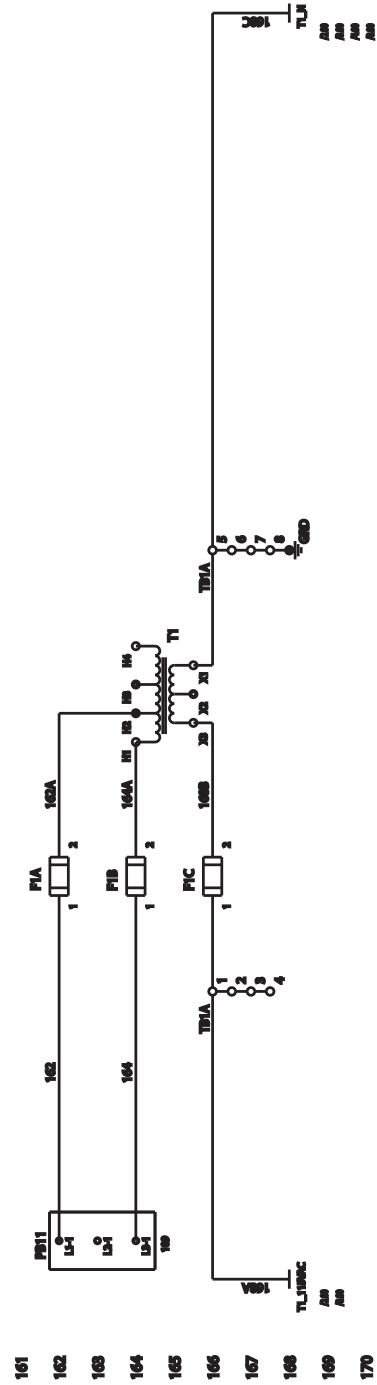
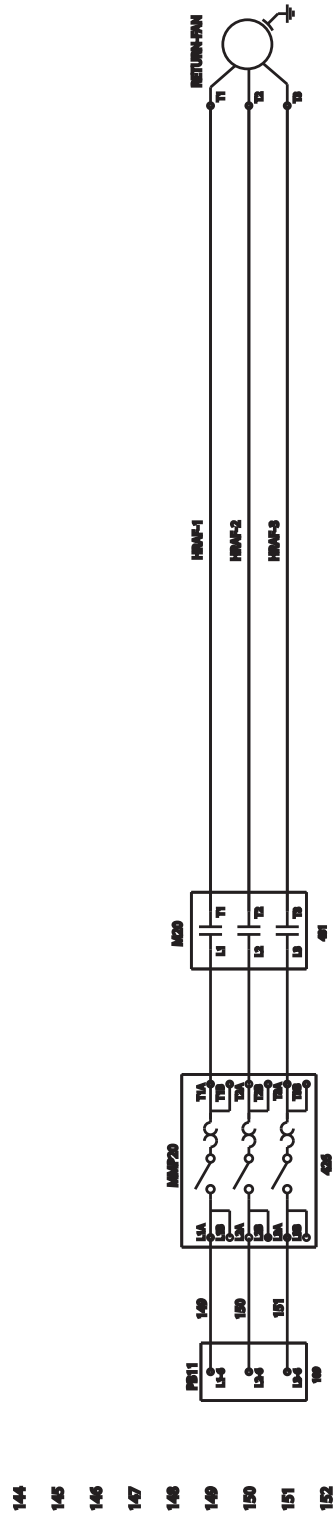
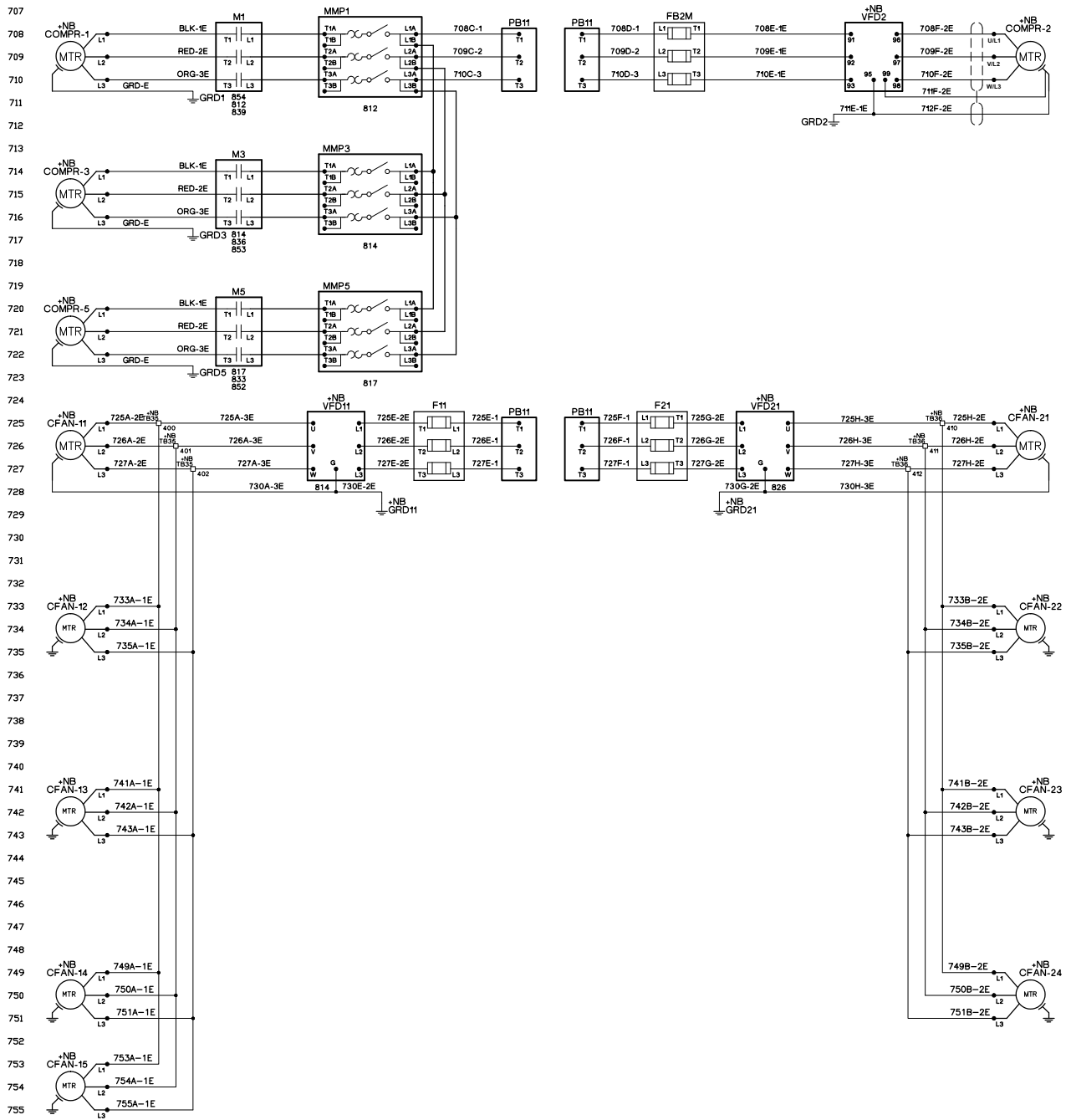

Figure 80: RPS 074 Condensing Unit Power (with Variable Speed Inverter Compressor)\*



\* Related control schematic on page 74 - page 76

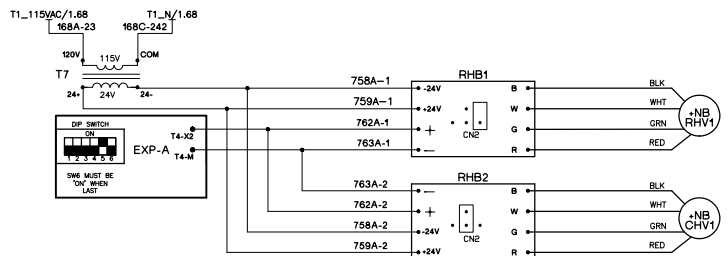

Figure 81: RPS 075 Condensing Unit Power (With SpeedTrol and Fixed Scroll Compressors)

702  
703  
704  
705  
706  
707  
708  
709  
710  
711  
712  
713  
714  
715  
716  
717  
718  
719  
720  
721  
722  
723  
724  
725  
726  
727  
728  
729  
730  
731  
732  
733  
734  
735  
736  
737  
738  
739  
740  
741  
742  
743  
744  
745  
746  
747  
748  
749  
750  
751  
752  
753  
754  
755  
756  
757  
758  
759

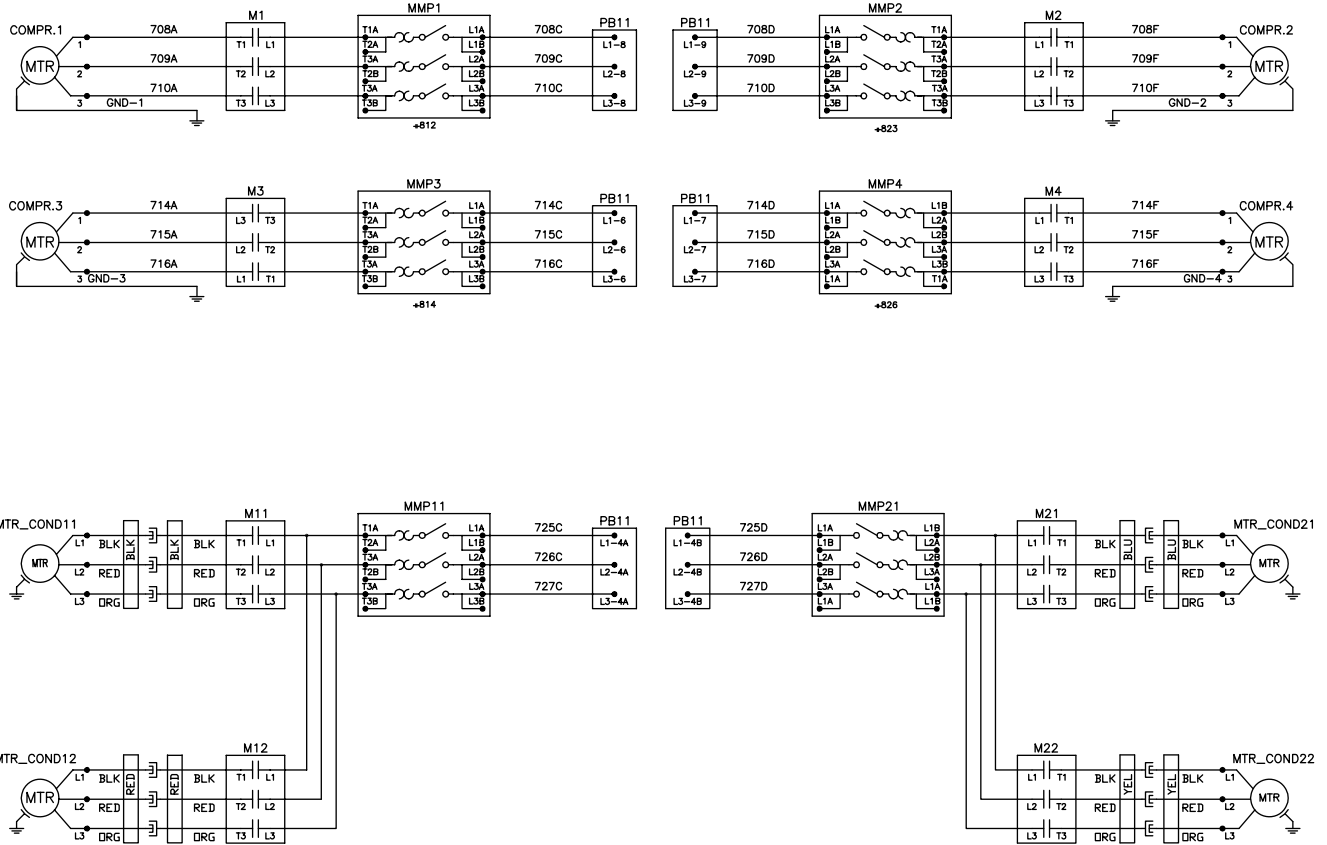



Figure 82: VFD Control (SAF and RAF)

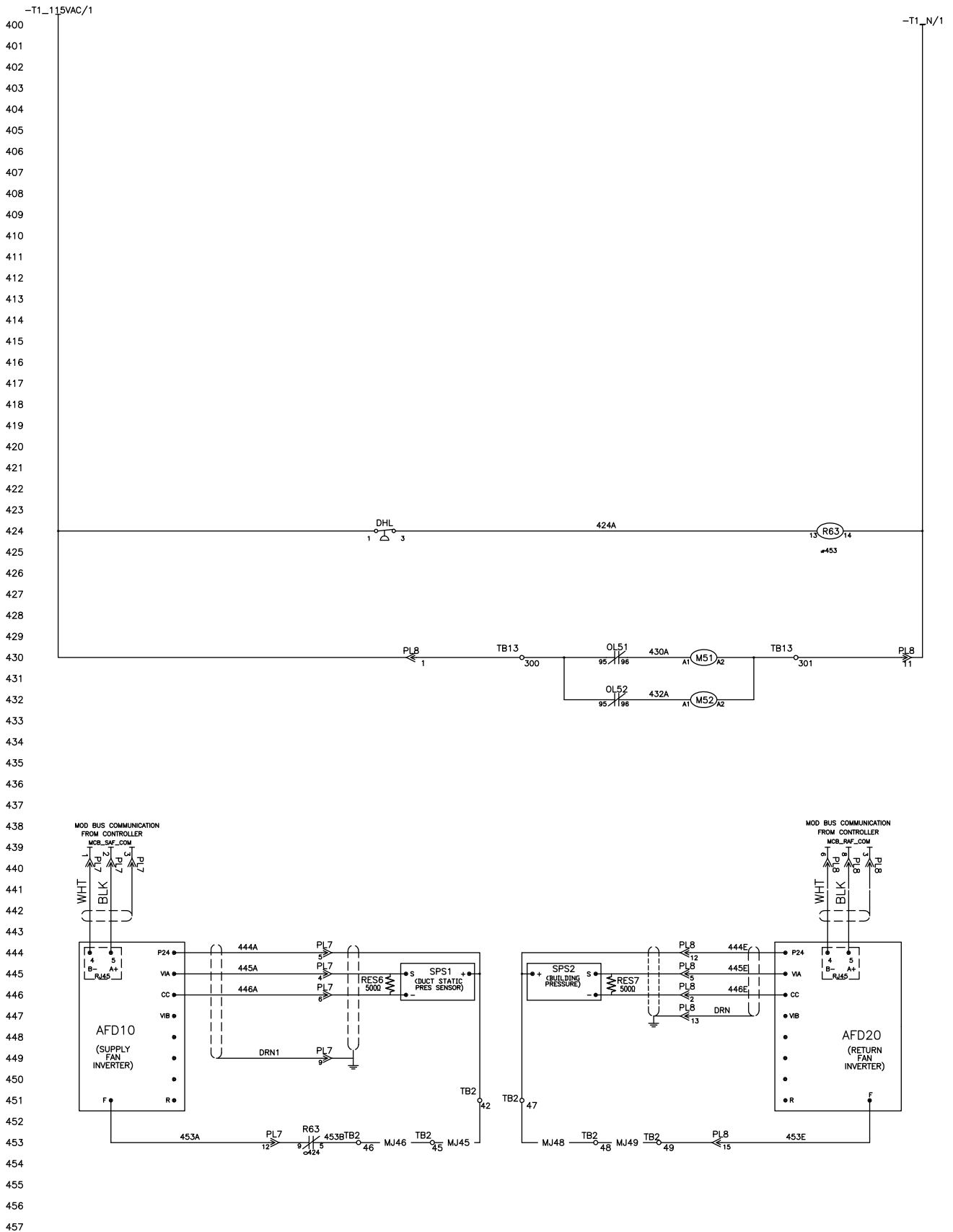
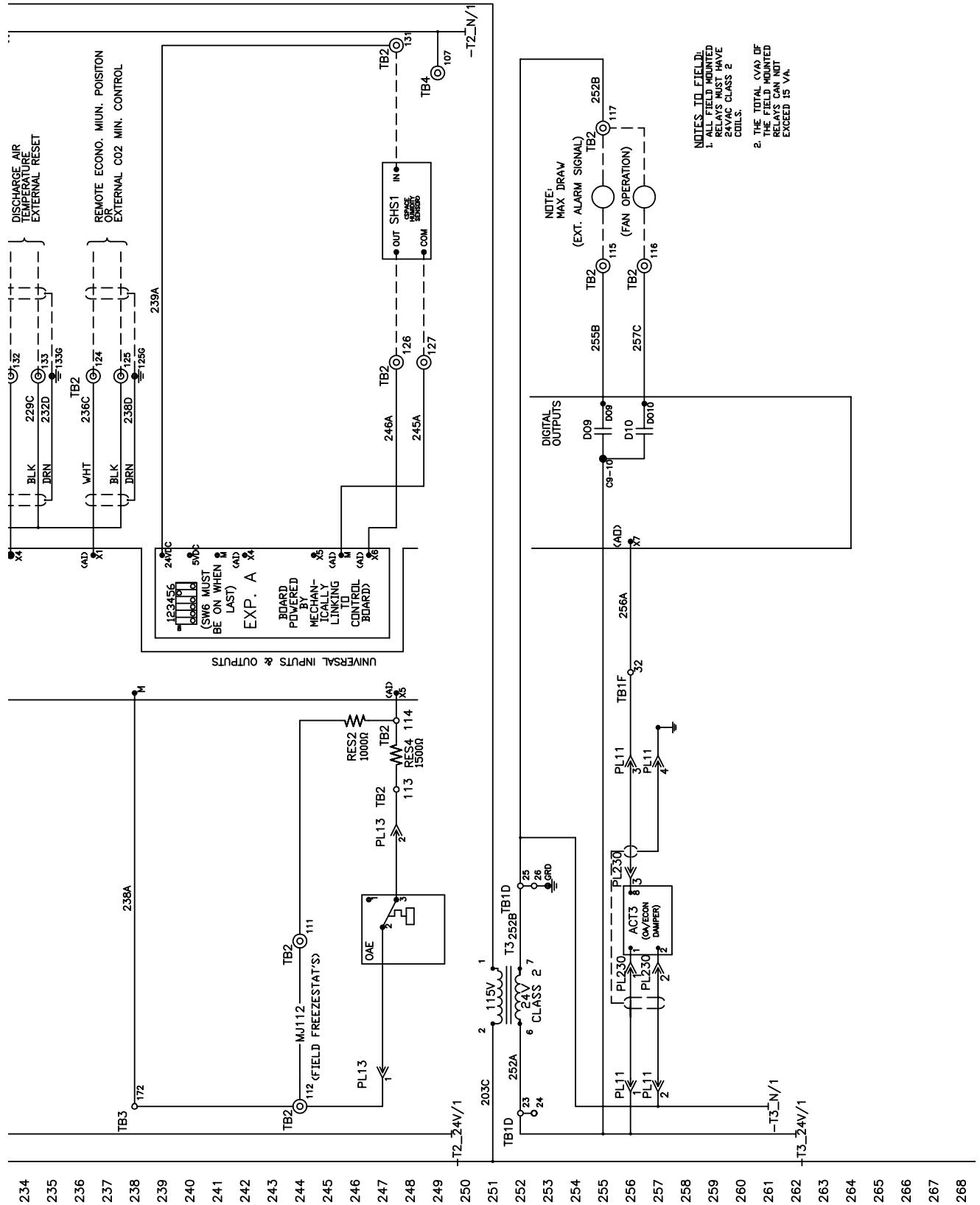

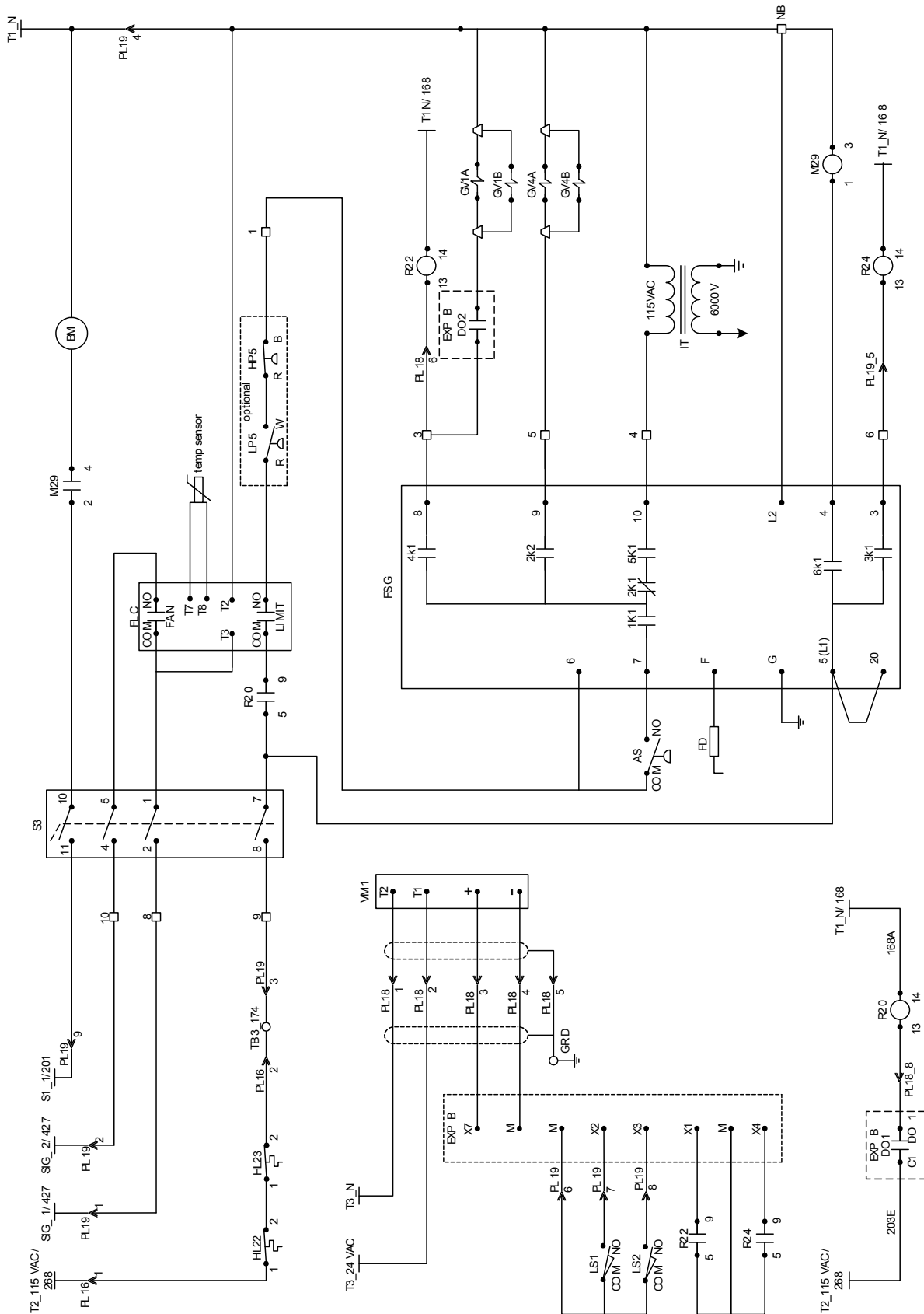

Figure 83 continued: VAV Control Inputs



NOTES TO FIELD:  
 1. ALL FIELD MOUNTED RELAYS MUST HAVE 24VAC CLASS 2 COILS.  
 2. THE TOTAL CVAS OF THE FIELD MOUNTED RELAYS CAN NOT EXCEED 15 VA.

Figure 84: HTD Gas Burner Schematic



Typical Sequence of Operation

When 120V power is furnished through the system on/off switch (S1), through the burner on/off switch (FLC), terminal #6 on the flame safeguard (FSG) is powered on a call for heat. Whenever power is restored to the flame safeguard, the flame safeguard will go through a 10 second initiation period before the prepurge period will begin. The burner air control valve will be at minimum position during off cycles. Upon a call for heat or any other time that a prepurge cycle will occur, the

Figure 84 continued: HTD Gas Burner Schematic

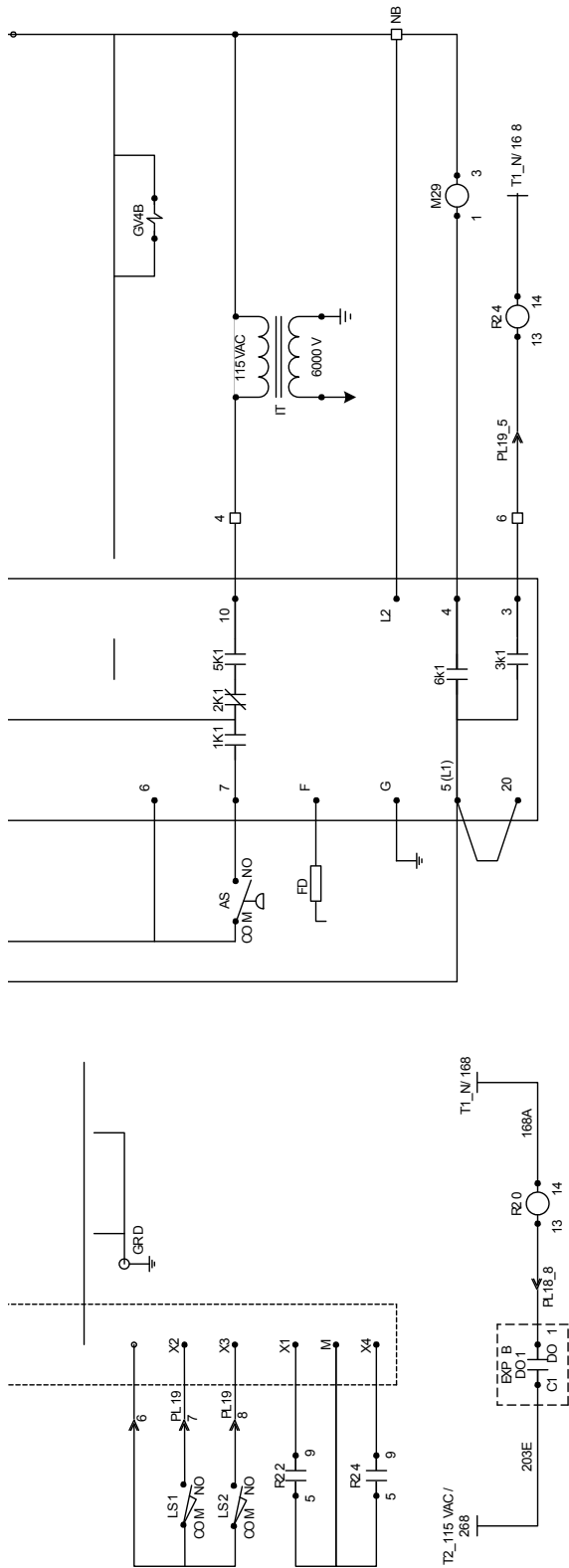

Typical Sequence of Operation

When 120V power is furnished through the system ON/OFF switch (S1), through the burner ON/OFF switch (S3), and through the high limit control (FLC), terminal #6 on the flame safeguard (FSG) is powered on a call for heat. Whenever power is restored to the flame safeguard, the flame safeguard will go through a 10 second initiation period before the prepurge period will begin. The burner air control valve will be at minimum position during off cycles. Upon a call for heat or any other time that a prepurge cycle will occur, the air control valve will be repositioned to the maximum position for the prepurge and then returned to the minimum position for low fire start.

Upon a call for heat, the controller will close (EMB-DO1) energizing terminal # 6 on the FSG. The FSG then energizes its terminal #4, which powers the burner combustion air blower motor (BM) and starts the prepurge cycle. The call for heat will also initiate the controller to reposition the burner air valve to its maximum open position for prepurge. When the actuator reaches the full open position, switch (LS2) is 'made' which will provide a digital input to the controller (EMB-DIX3). This digital input will initiate a 20 second (adjustable) timing period in the controller. At the completion of the timing period, the controller will signal the actuator to drive to its minimum (low fire) position. At the completion of the FSG prepurge cycle the valve will be at the minimum open position and the minimum position switch (LS1) will be 'made', providing a digital input to the controller (EMB-DIX2). When the burner air valve is at its minimum position and the low position switch (LS1) is made, the controller will close the digital output (EMB-DO2) allowing the combination gas valve(s) (GV1) to be energized upon completion of the FSG prepurge cycle.

After completion of the FSG prepurge period there will be a 10 second trial for ignition during which terminal #8 (combination gas valve - GV1) and terminal #10 (ignition transformer - IT) will be energized. If flame is being detected through the flame rod (FD) at the completion of the 10 second trial for ignition period, terminal #10 (ignition transformer - IT) will be de-energized and terminal #9 (main gas valves - GV4) will be energized and the control system will be allowed to control the firing rate once the heating stage timer (default 5 minutes) has passed. After the flame has lit and been proven and the heating stage time has passed, the controller will modulate (VM1), to the required firing rate. In the event the flame fails to ignite or the flame safeguard fails to detect its flame within 10 seconds, terminals #4, 8, 9, and 10 will be de-energized, thus de-energizing the burner. The FSG would then lockout and would require manual resetting. If the FSG goes into lockout, terminal 3 on the FSG will be energized and will energize R24, providing a digital input to the controller (EMB-DIX2) if an attempt is made to restart the burner by resetting the FSG or if an automatic restart is initiated after flame failure the earlier described prepurge cycle with the wide open air valve will be repeated. If the unit overheats, the high limit control (FLC) will cycle the burner, limiting furnace temperature to the limit control set point. The flame safeguard contains 'LEDS' (lower left corner) that will glow to indicate operation.

Figure 85: Electric Heat Control

NOM. KW --- NOM. VOLTS  
 120 --- 380/480/600

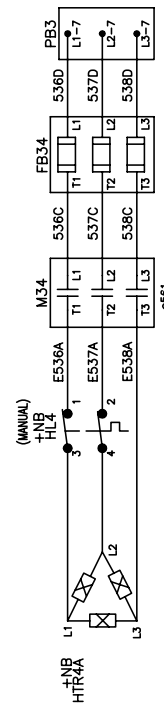
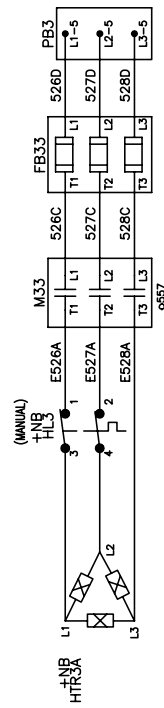
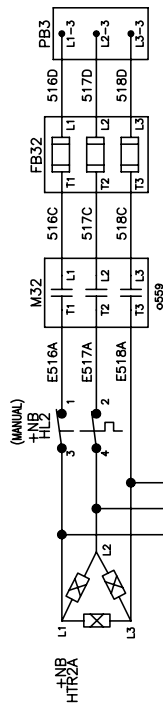
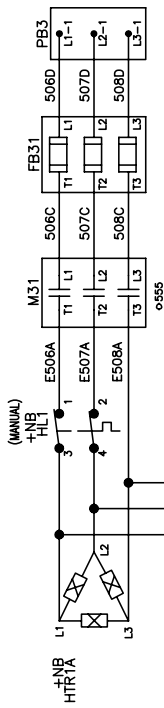
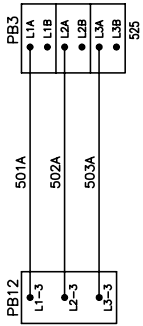

500  
 501  
 502  
 503  
 504  
 505  
 506  
 507  
 508  
 509  
 510  
 511  
 512  
 513  
 514  
 515  
 516  
 517  
 518  
 519  
 520  
 521  
 522  
 523  
 524  
 525  
 526  
 527  
 528  
 529  
 530  
 531  
 532  
 533  
 534  
 535  
 536  
 537  
 538  
 539

Figure 85 continued: Electric Heat Control

530  
531  
532  
533  
534  
535  
536  
537  
538  
539  
540  
541  
542  
543  
544  
545  
546  
547  
548  
549  
550  
551  
552  
553  
554  
555  
556  
557  
558  
559  
560  
561  
562  
563  
564  
565  
566  
567

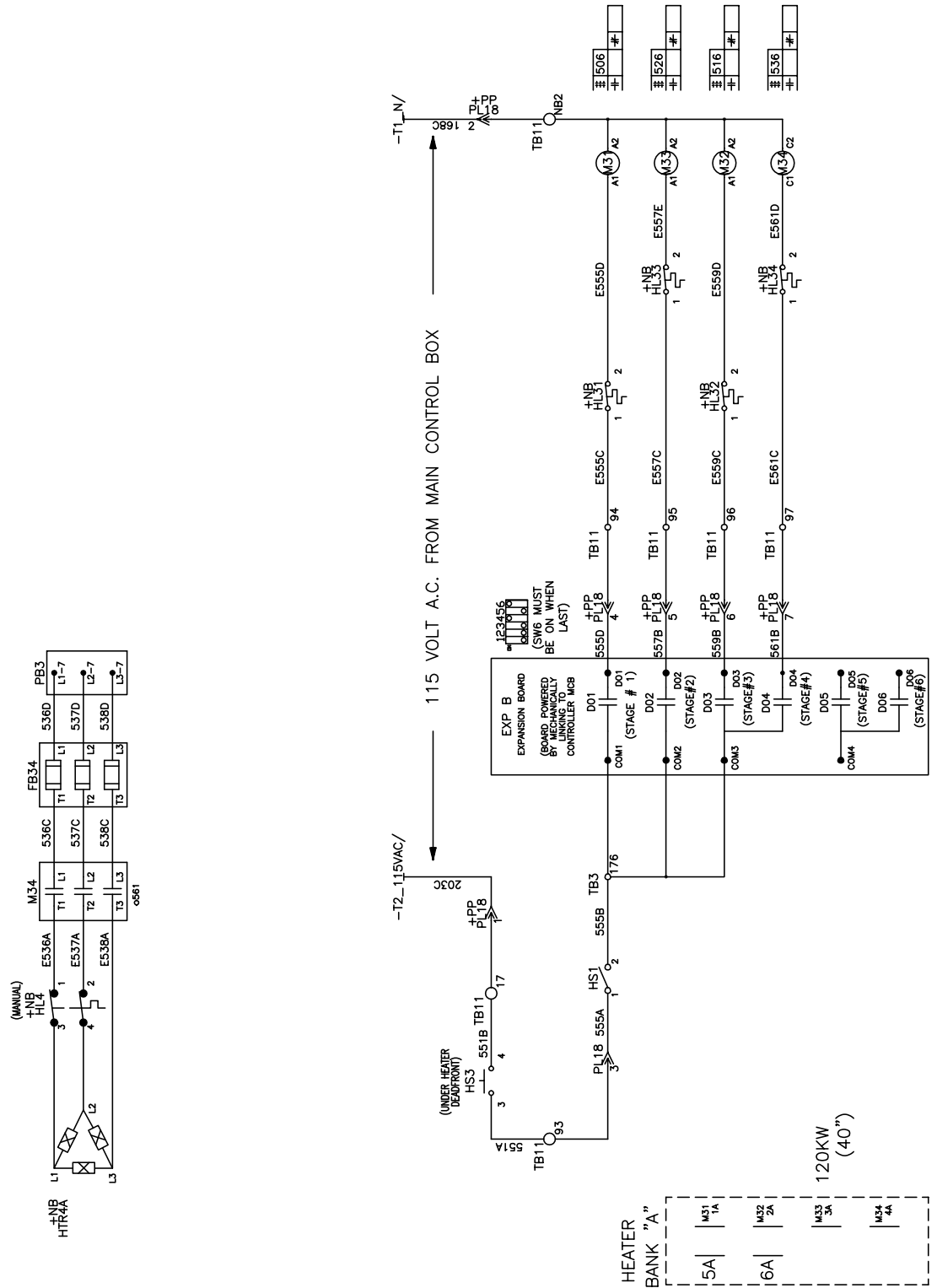

Figure 86: RPS 061 Condensing Unit Control (With Fixed Speed Scroll Compressors)

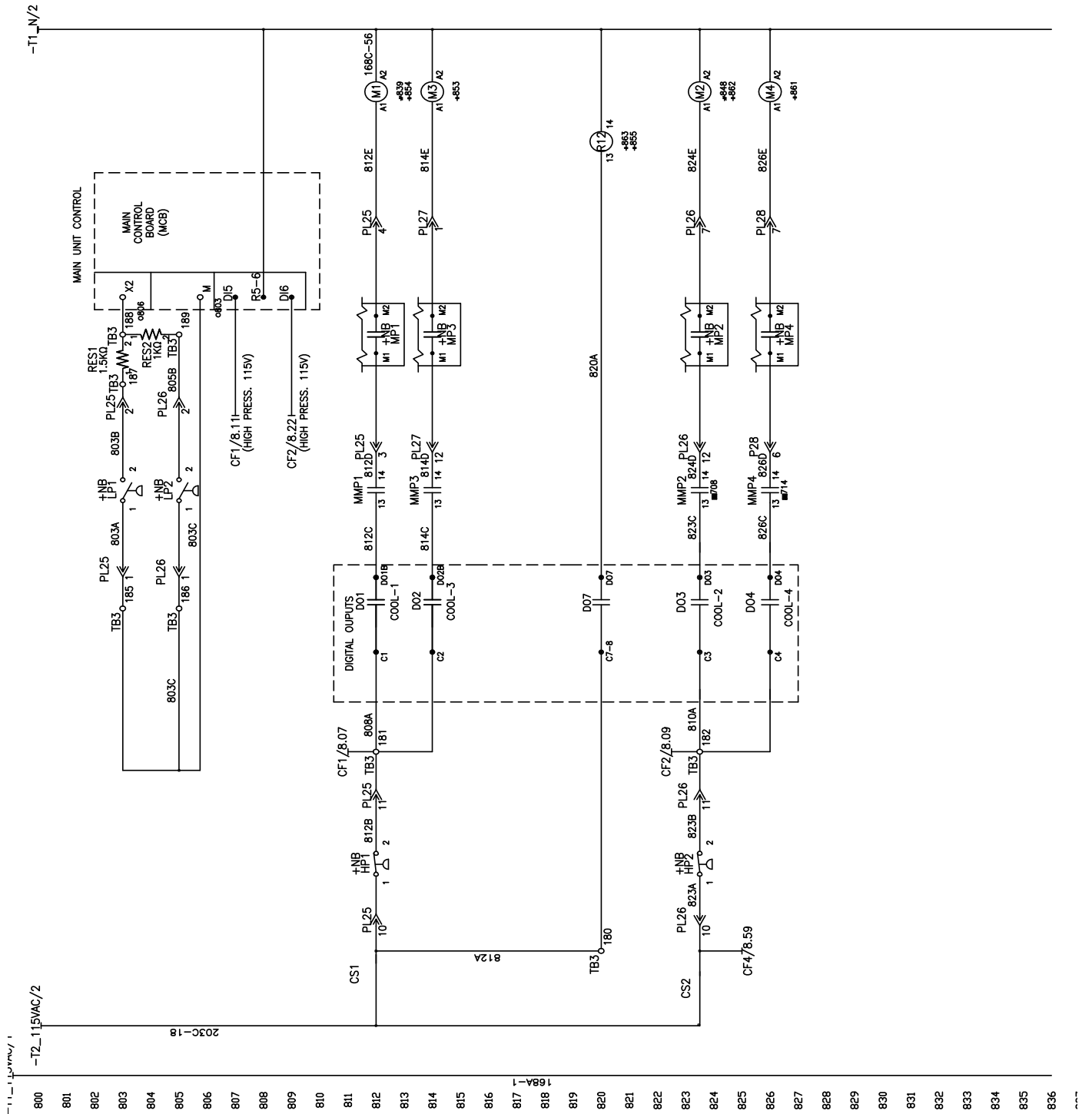
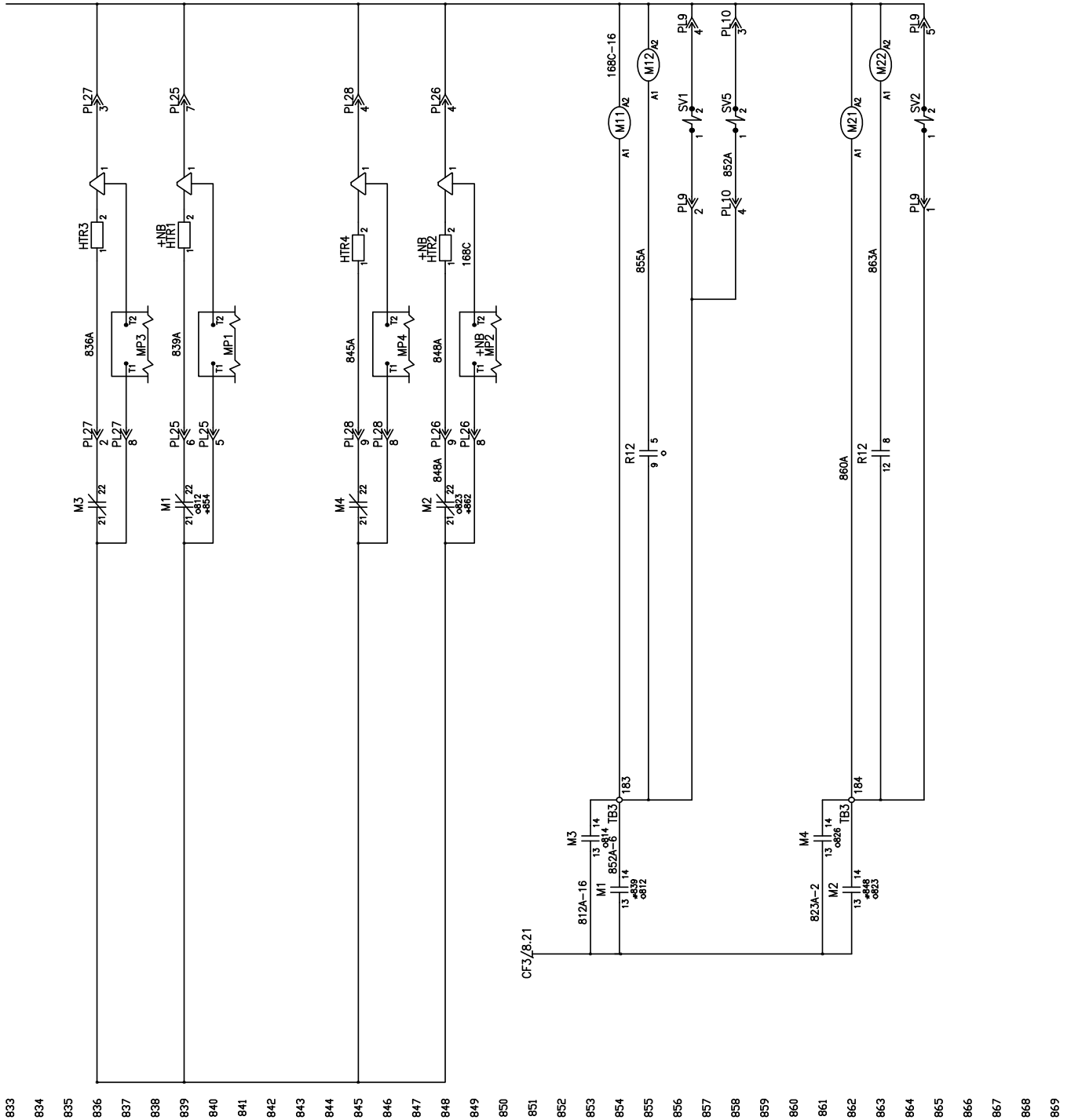



Figure 86 continued: RPS 061 Condensing Unit Control (With Fixed Speed Scroll Compressors)



833  
834  
835  
836  
837  
838  
839  
840  
841  
842  
843  
844  
845  
846  
847  
848  
849  
850  
851  
852  
853  
854  
855  
856  
857  
858  
859  
860  
861  
862  
863  
864  
865  
866  
867  
868  
869

Figure 87: RPS 074 Condensing Unit Control (with Variable Speed Inverter Compressors)

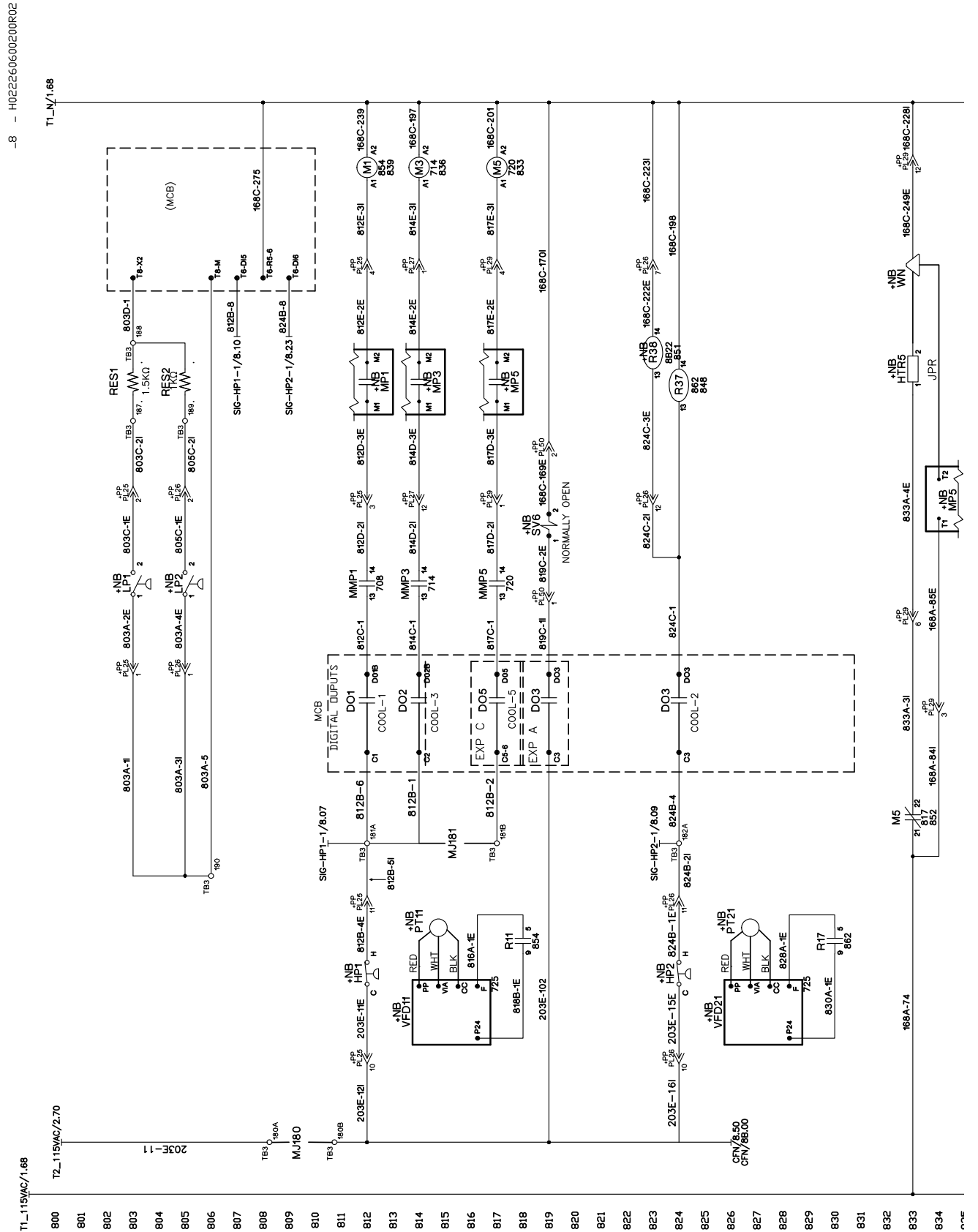
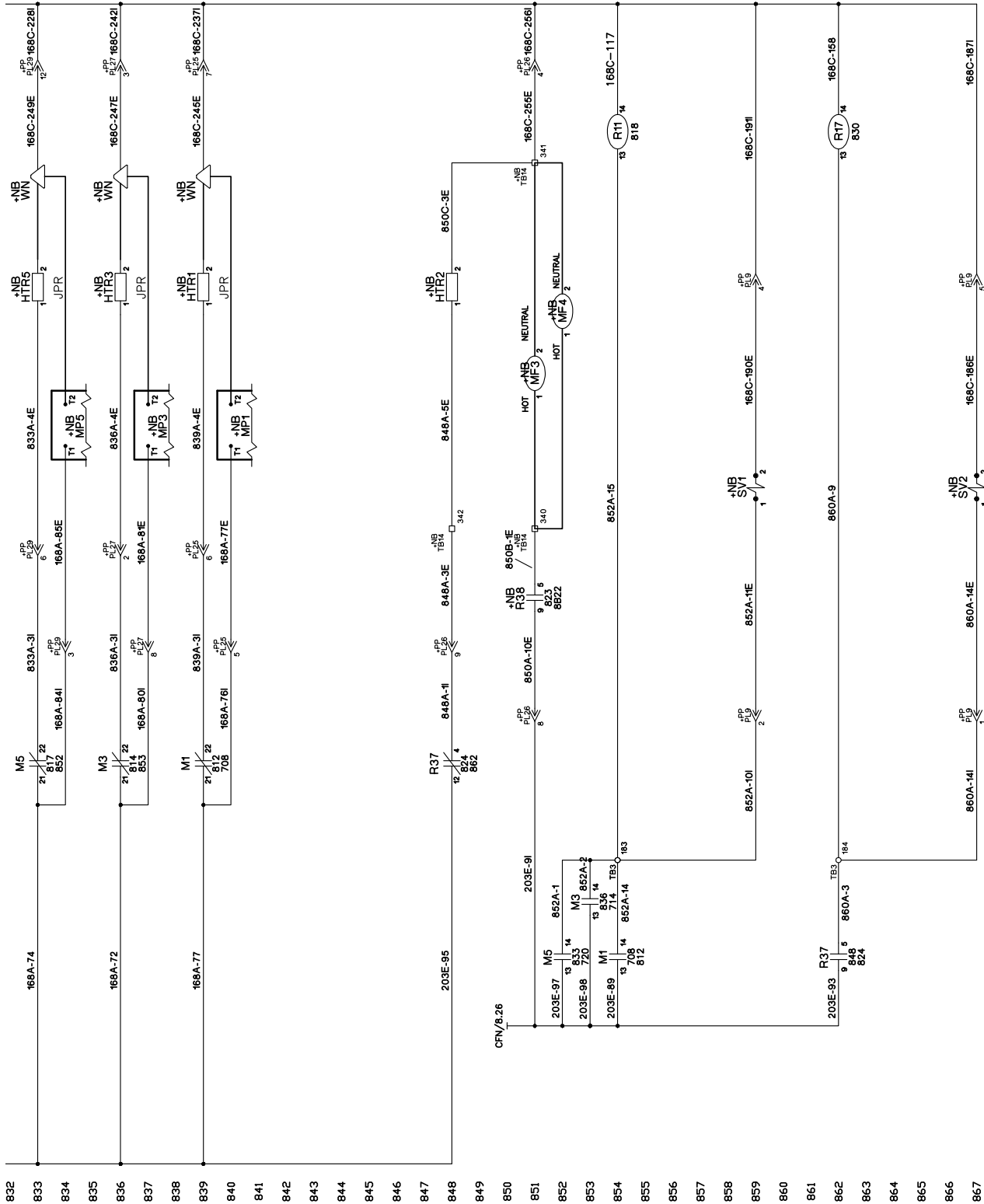

Figure 87 continued: RPS 074 Condensing Unit Control (with Variable Speed Inverter Compressors)\*



\* Related control schematic on page 63

Figure 88: RPS 074 Compressor Control (with Variable Speed Inverter Compressor)

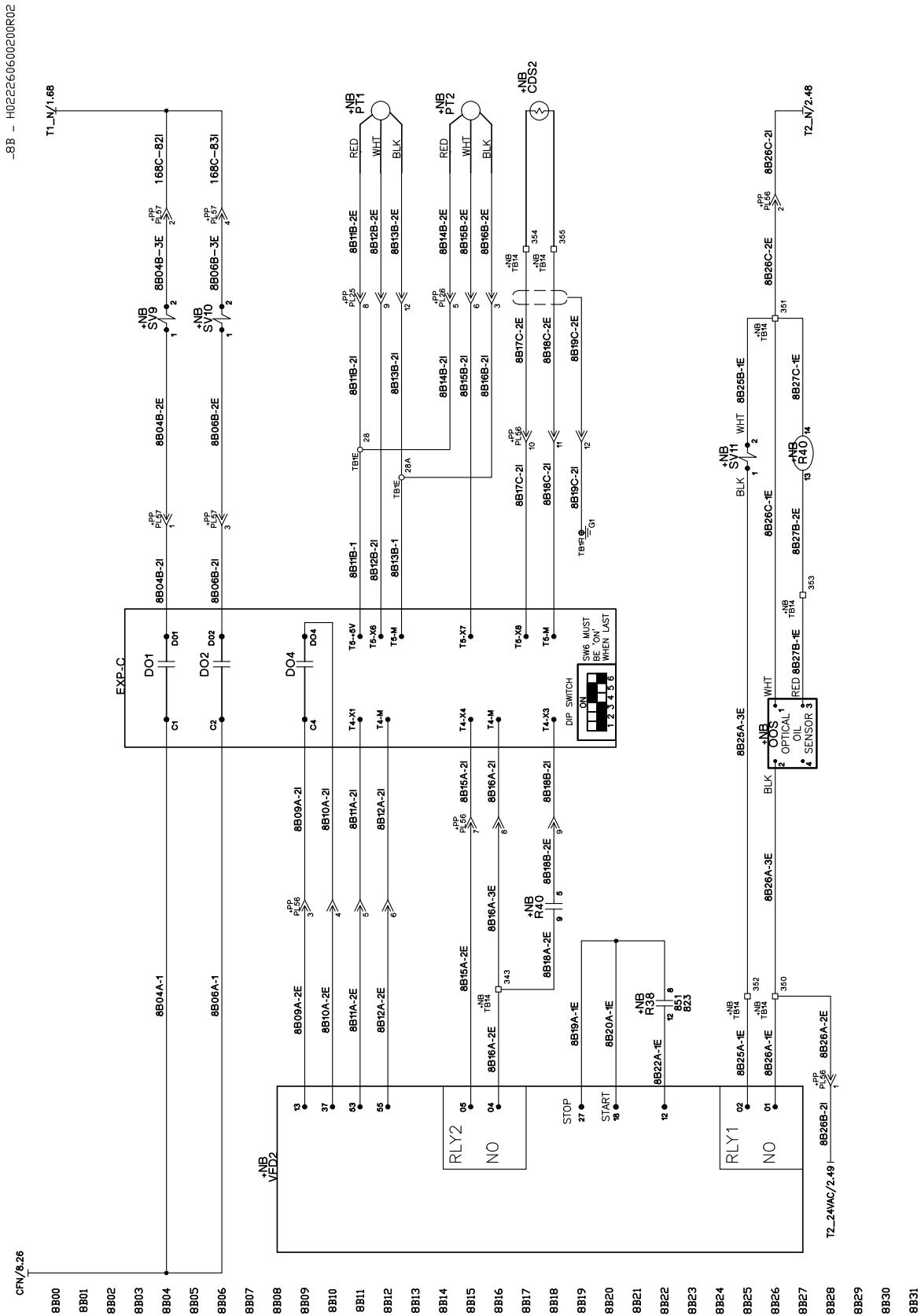

Figure 86 continued: CV Fan Control (SAF and RAF)

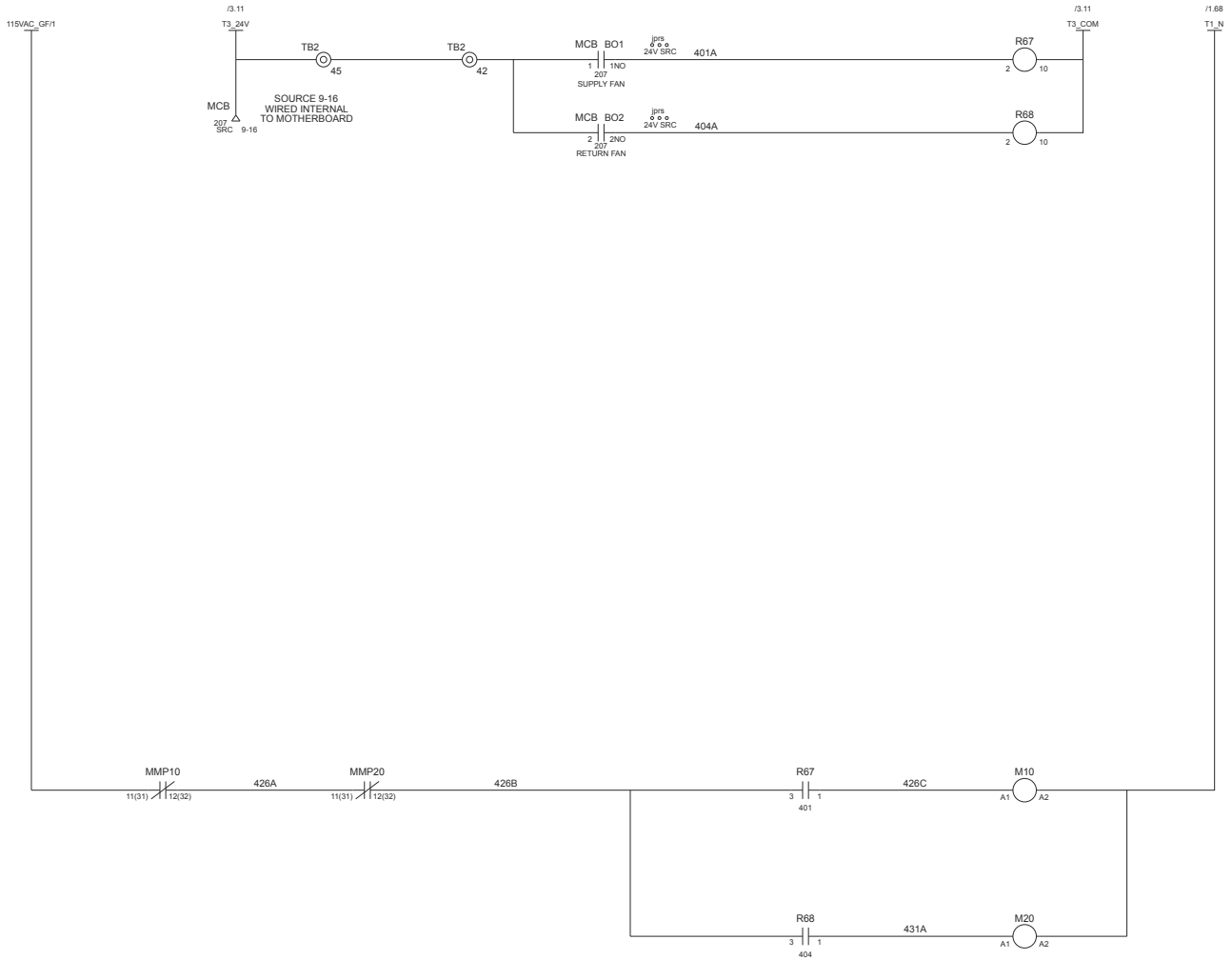
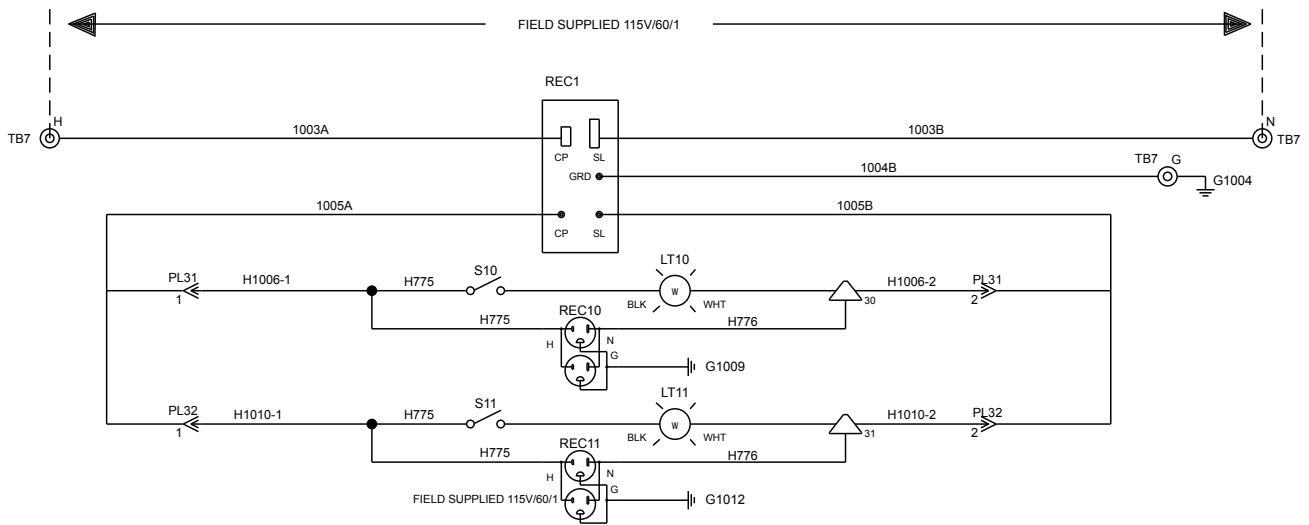

Figure 89: Light and Receptacle Power (Field Power)



## Control Actuators

The actuators are controlled by an analog signal from the unit controller. Damper actuators utilize a 0-10 V (dc) analog signal while modulating heating/cooling valve actuators utilize a 2-10 V (dc) signal. Spring-return actuators are used for the 0-30% outdoor air and economizer dampers. The mixing dampers are normally closed to the outside air.

Figure 90: Control Actuators Wiring Diagram

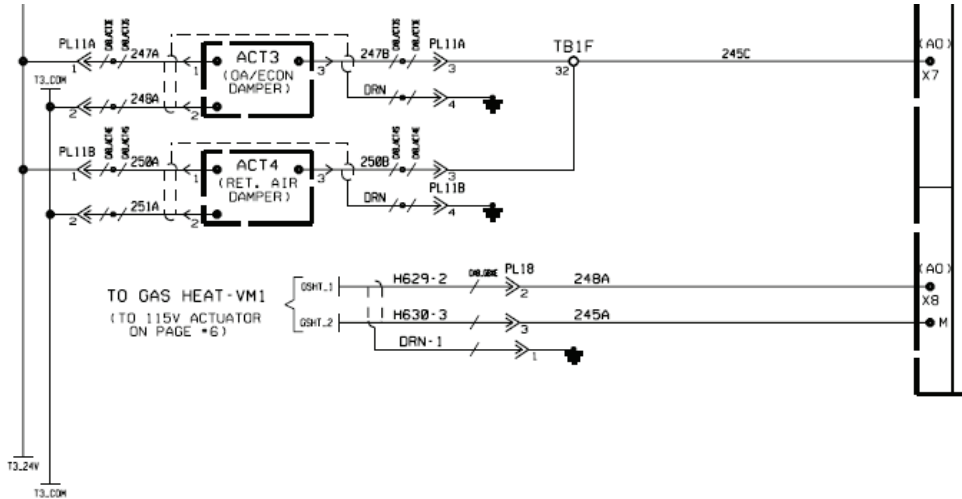

## Enthalpy Control

### Outside Air Enthalpy Control (OAE)

Units with MicroTech control and an economizer come standard with an electromechanical enthalpy control device (OAE) that senses both the humidity and temperature of the outside air entering the unit. This device has an enthalpy scale marked A through D. Table 18 shows the control points at 50% RH for settings A through D. Figure 91 shows this scale on a psychrometric chart. When the outside air conditions exceed the setting of the device, the outside air dampers are positioned to the minimum outside air intake position by the MicroTech controller.

Table 18: Enthalpy Control Settings

Control curve	Control point temperature at 50% RH
A	73°F (23°C)
B	70°F (21°C)
C	67°F (19°C)
D	63°F (17°C)

Figure 91: Enthalpy Control Settings

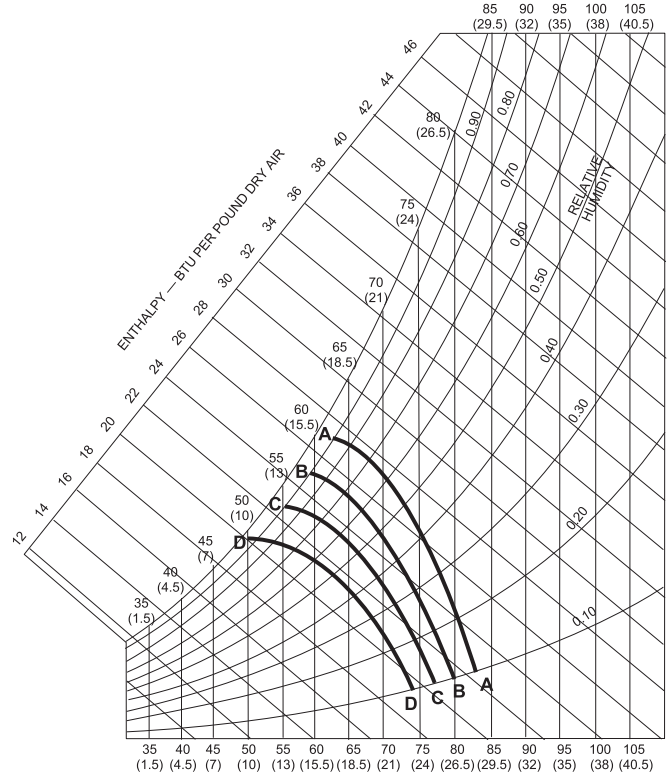

### **Differential Enthalpy Control (OAE/RAE)**

An optional electric differential enthalpy control arrangement (OAE/RAE) is available on units with MicroTech control. In this configuration a solid-state humidity and temperature sensing device is located in both the return (RAE) and outside intake (OAE) airstreams. This OAE device has the same A through D scale as the device described above. However, with the OAE/RAE arrangement the switch on, OAE must be set all the way past the D setting. With this done, the MicroTech controller adjusts the return and outside air dampers to use the airstream with the lowest enthalpy.

### **Ground Fault Protection**

The ground fault protection is designed to protect motors from destructive arcing ground faults. The system consists of a ground fault relay and a ground fault current sensor. The ground fault relay employs solid state circuits that will instantly trip and open a set of relay contacts in the 115-volt control circuit to shut the unit down whenever a ground fault condition exists. The ground fault relay is self powered. The ground fault sensor is a current transformer type of device located on the load side of the power block through which the power wires of all phases are run.

### **Phase Voltage Monitor**

The phase voltage monitor (see [page 133](#)) protects against high voltage, phase imbalance, and phase loss (single phasing) when any one of three line voltages drops to 74% or less of setting. This device also protects against phase reversal when improper phase sequence is applied to equipment, and low voltage (brownout) when all three line voltages drop to 90% or less of setting. An indicator run light is ON when all phase voltages are within specified limits. The phase voltage monitor is located on the load side of the power block with a set of contacts wired to the 115-volt control circuit to shut the unit down whenever the phase voltages are outside the specified limits.

## Modulating Hot Gas Reheat

In the dehumidification mode, mechanical cooling is used to cool air low enough to lower the moisture content of the air and then reheated to comfort conditions.

Figure 92: Dual 2-Way Valve Refrigeration Schematic

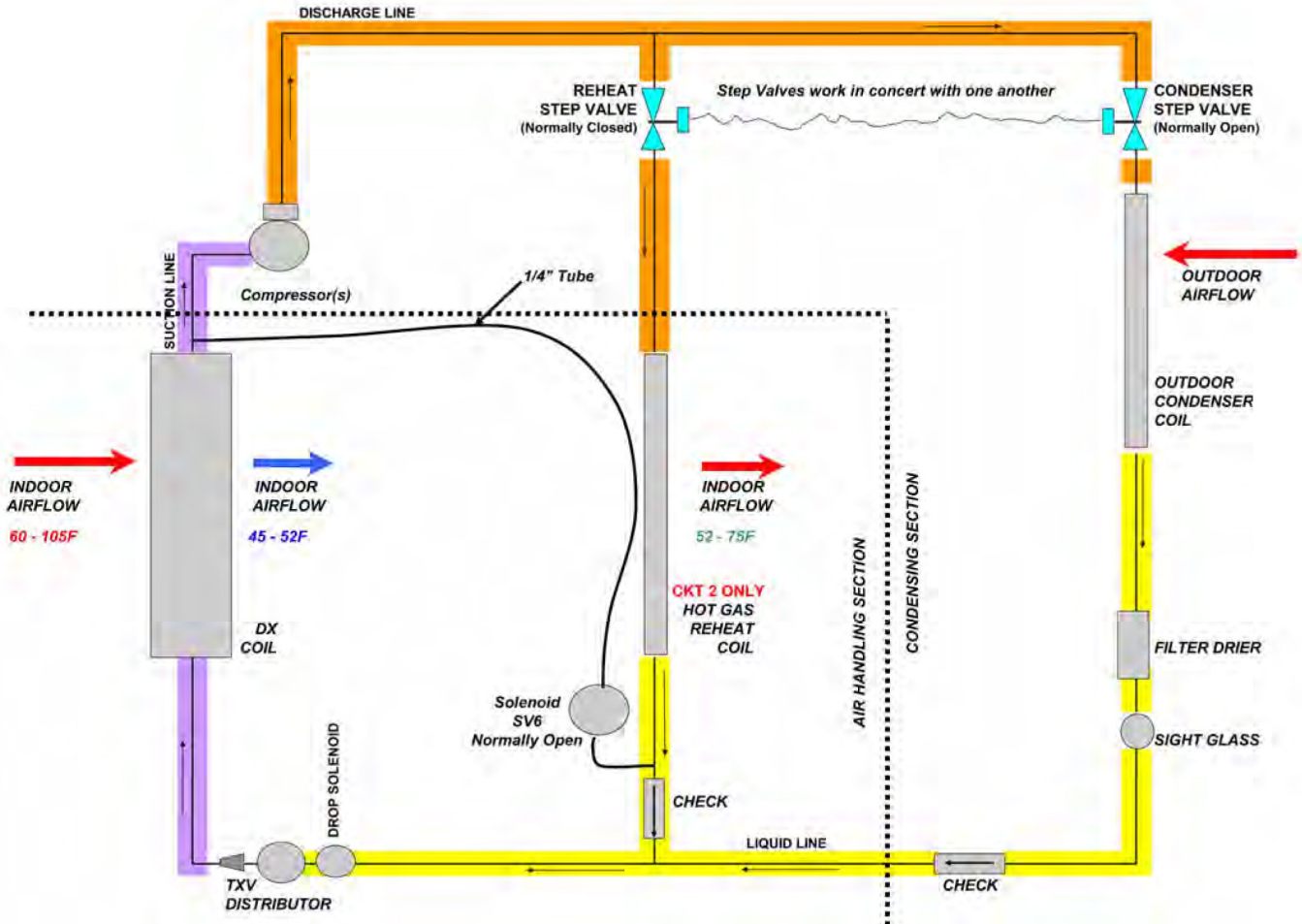

**NOTE:** Condenser Step Valves are for variable speed compressor units only. Each refrigerant circuit contains a solenoid valve to block refrigerant flow to the upper half of the condenser coil, for low load /low ambient conditions.

Figure 93: Ideal for Neutral Air Ventilation Control

- The rooftop mainly dehumidifies the required ventilation air
- Terminal units provide additional sensible cooling as required

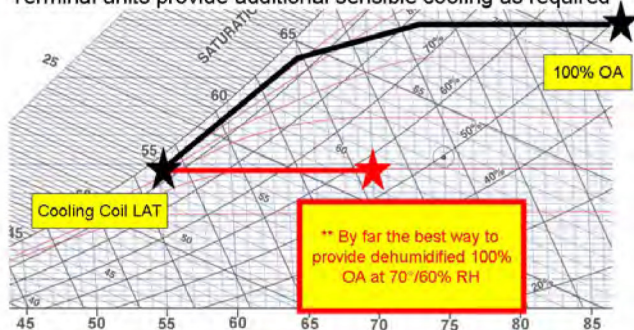



## Dehumidification Initiation

An analog sensor is mounted in the return duct, the space, or outdoors to sense Relative Humidity. The location is selected by setting the Sensor Location value on the keypad to Return, Space, or OAT. OAT can only be selected for units with DAT control. Dehumidification is disabled when the unit is in either the Heating or Minimum DAT state. When Dehumidification is enabled, Dehumidification operation is initiated when Humidity Control is set to either Relative Humidity or Dew Point and that value rises above the appropriate set point by more than half its deadband. Economizer operation is disabled in the Dehumidification mode so the unit immediately transitions to Cooling if Dehumidification is initiated in Economizer state.

## Dehumidification Termination

Dehumidification is terminated if the selected variable, Relative Humidity or Dew Point, drops below the appropriate humidity set point by more than half its deadband. Dehumidification is also terminated if cooling is disabled for any reason or the unit enters either the Heating or Minimum DAT state. For units with compressors, the number of cooling stages is reduced by one and control reverts to normal control when dehumidification is terminated in the Cooling state. Another compressor stage change could then occur after one Cooling Stage Time has elapsed.

## Control & Arrangement

In conjunction with dehumidification, MHGRH is used to raise the temperature of the cooled air to a desirable value. MHGRH is comprised of a parallel coil arrangement, with both the condenser and reheat coils of the micro channel type, dual reheat valves (which operate in concert with one another) and a check valve. MHGRH components will always be installed in circuit #2.

During Dehumidification control w/ modulating Hot Gas Reheat (MHGRH) an analog signal (0-10Vdc) is controlled as described here.

- A PI Loop is used to control the HGRH valves to maintain the Discharge Air Temperature from the reheat coil.
  - Compressor staging during reheat (or dehumidification) will be controlled by the Leaving DX Coil Temperature. For increased dehumidification during reheat, the standard default compressor staging range is 45 - 52°F.
  - When dehumidification is active in the Cooling state, the reheat set point equals the DAT Cooling Set point. For DAT units, this is the normal DAT set point resulting from any reset. For Zone Control units, this set point is the result of a PI Loop based on the Control Temperature.
  - Communication with the reheat control valves is accomplished by providing a 0-10Vdc signal to a pair of interface boards which in turn supply the control signal to the reheat valves (step type).
- In the Fan Only state, no sensible cooling is required, but the dehumidification mode will still be enabled if the dew point or humidity sensor is not satisfied. In this case the reheat set point varies from a maximum value (default 65°F) when the Control Temperature is at or below the heating changeover set point to a minimum value (default 55°F) when the Control Temperature is at or above the cooling changeover set point.
  - Lead/Lag Arrangement w/ MHGRH (when applicable)
    - Alternate staging with circuit #1 as lead will be the standard default arrangement.
    - During cooling mode, circuit #1 will lead and load up before starting circuit #2.
    - During reheat mode, circuit #2 will lead and load up before starting circuit #1.
    - For reheat operation, compressor(s) in circuit #2 must be active. If the unit is operating in the cooling mode when a call for dehumidification/reheat arises, circuit #2 will become the lead and the controller will bring on an additional stage of cooling for dehumidification. If any compressors in circuit #1 are operating at this moment they will be switched over to compressors in circuit #2. Dehumidification operation is disabled if circuit #2 is disabled for any reason.
  - In the reheat mode, the minimum position for the reheat valves is 10% (1.0 Vdc). The controller will modulate the reheat valves from this starting position.
  - Reheat valve(s) must be at 0% (0 Vdc) position before starting the first compressor in the reheat circuit to prevent pressure spikes.
  - Upon termination of dehumidification (reheat), the maximum ramp down or decay rate of the reheat control valves shall be 1% per sec (or 0.1V per sec).
  - Upon termination of dehumidification (reheat), staging of compressor(s) is delayed for 1 minute after reheat capacity = 0% (0Vdc).
  - Every 24 hours, the reheat control valves will be driven to their maximum position (10Vdc) and then returned to their normal operating position (0Vdc). If unit is operating in cooling or dehumidification (reheat) at the prescribed time it will be deferred to the next time.
  - Dehumidification status can now be found under the MicroTech main system menu. Reheat capacity (valve position) can also be found under the main system menu, display based on percentage (0-100%).
  - A solenoid (SV6) and a check valve is provided to the reheat refrigeration circuit. The solenoid is normally open and removes refrigerant from the reheat portion of the refrigerant circuit when Reheat is inactive. When Reheat is active, the solenoid closes and isolates the reheat portion of the refrigeration circuit. When the solenoid is in the open position, it meters refrigerant flow and flushes the refrigerant as it enters the suction line. This feature reduces the amount of refrigerant needed for reheat up to 75%, compared to a flooded system arrangement.

## Hot-Gas Bypass (HGBP)

**CAUTION**

Lifting points may not be symmetrical to the center of gravity of the unit. Ballast or unequal cable lengths maybe required.

Hot-gas bypass (Figure 94) provides protection against low suction and frosting. It also helps keep the unit operating at light load without excessive cycling.

The system consists of a pressure regulating valve that starts to modulate open at 100 psig (32°F). The valve is fully open at 90 psig (26°F). The factory settings can be modified in the field as the valve is adjustable.

Adjustments are made by turning the adjustment screw clockwise (to increase valve set point) or counter clockwise. The average psi change per turn is 16 psi.

On split systems, it is recommended to mount the HGBP valve near the condensing unit to minimize refrigerant and oil lagging in the line upstream. The HGBP line downstream from the valve will need to be insulated against sweating because it is exposed to low temperatures.

**NOTE:** The regulating valve opening point can be determined by slowly reducing the system load or reducing the required discharge air temperature setting while observing the suction pressure. When the bypass valve starts to open, the refrigerant line on the evaporator side of the valve will begin to feel warm as your hand approaches the copper tube.

**HGBP is not recommended for variable speed inverter compressors.**

## External Time Clock

You can use an external time clock as an alternative to (or in addition to) the MicroTech controller’s internal scheduling function. The external timing mechanism is set up to open and close the circuit between field terminals 101 and 102. When the circuit is open, power is not supplied to binary input MCB-B11. This is the normal condition where the controller follows the programmable internal schedule. When the circuits closed, power is fed to B11. The MicroTech controller responds by placing the unit in the occupied mode, over riding any set internal schedule. For more information, see the “Digital Inputs” section of [IM 919](#), “MicroTech Applied Rooftop Unit Controller.”

Figure 94: Hot-Gas Bypass (HGBP) Diagram

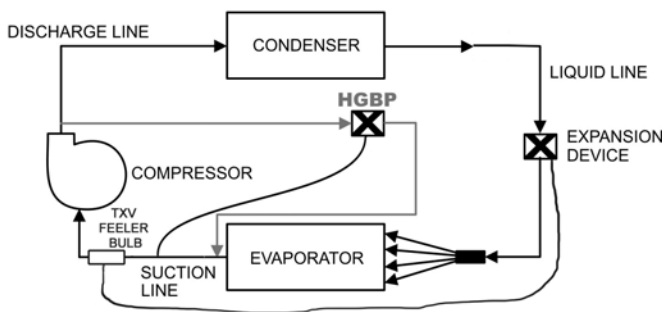

## Smoke and Fire Protection

**DANGER**

Improper smoke, fire, or fume air handling can result in severe personal injury or death.

Daikin Applied optionally offers factory installed outdoor air, return air, and exhaust air dampers as well as smoke detectors in the supply and return air openings, complete with wiring and control. These components often are used in the building's smoke, fume, and fire protection systems. However, due to the wide variation in building design and ambient operating conditions into which our units are applied, we do not represent or warrant that our products will be fit and sufficient for smoke, fume, and fire control purposes. The owner and a fully qualified building designer are responsible for meeting all local and NFPA building code requirements with respect to smoke, fume, and fire control.

### Smoke Detectors

Field installed smoke detectors in the return air ductwork or the supply air ductwork can be coordinated with the units operation through the unit controller's binary input, D14. This input is wired to TB2 and the supply air smoke detector can be wired between terminals 103 and 104 and the return air smoke detector can be wired between terminals 104 and 105. The T2 transformer supplies 24 V (ac) across each of these terminals and a dry set of contacts can be wired to these terminals respectively. This and additional wiring information can be seen on the input wiring schematics at line number 220.

Factory installed smoke detectors have similar wiring and the control sequence is as follows:

When smoke is detected by either sensor, the normally closed sensor contacts open. This removes power from binary input B18 on the main control board.

The MicroTech controller responds by shutting down the unit. The controller is placed in the Alarm Off state and cannot be restarted until the alarm is manually cleared. Refer to the operation manual supplied with the unit for information on clearing alarms.

The smoke detectors must be reset manually once they have been tripped. Power must be cycled to the smoke detector to reset.

### Emergency Shutdown

The terminals 105 & 106 on TB2 can be used for any field supplied component that requires a unit emergency shutdown. When these terminals are used, the factory installed jumper must be removed.

Figure 95: Smoke Detector Schematic

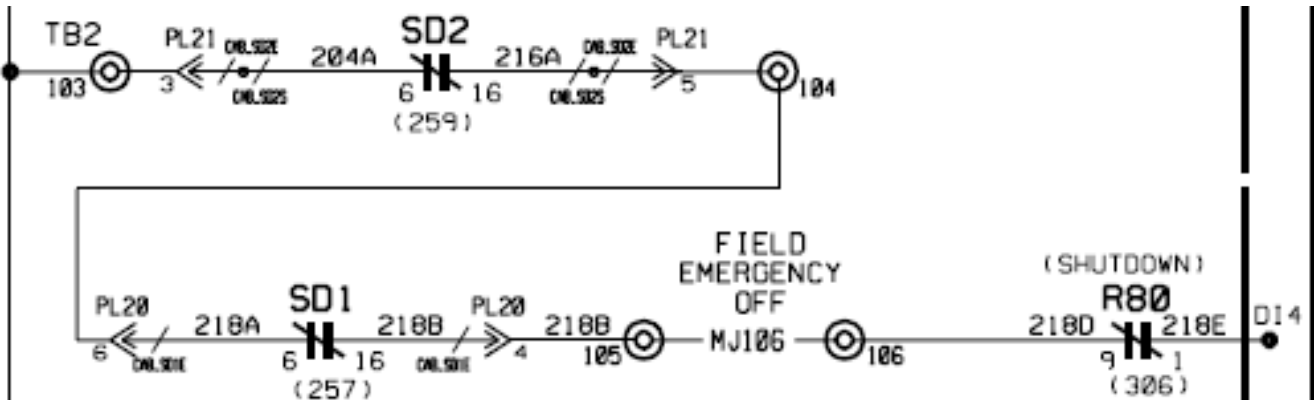

### Freeze Protection

An optional freezestat is available on units with MicroTech control that have hot water, chilled water, or steam heating coils. The sensing element is located on the downstream side of the heating coil in the heating section of the unit. If the freezestat detects a freezing condition and closes, the MicroTech controller takes different actions, depending on whether the fans are ON or OFF. The freezestat is an auto reset type of control; however, the controller alarm that it causes is manually reset if the fan is on and auto reset if the fan is OFF.

#### Fan ON Operation

If the freezestat detects a freezing condition while the fan is on, the MicroTech controller shuts down the fans, closes the outdoor air dampers, opens the heating valve, and sets a 10 minute timer. The MicroTech controller’s active alarm is “Freeze Fault.”

When the 10-minute timer expires, the controller begins checking the freezestat again. If the freezestat is open, the heating valve closes. If the freezestat closes again, the heating valve opens, and the 10-minute timer resets.

The unit remains shut down until the “Freeze Fail” alarm is manually cleared. Refer to the operation manual supplied with the unit for information on clearing alarms ([OM 138](#) or [OM 137](#)).

#### Fan OFF Operation

If the freezestat detects a freezing condition while the fan is off, the MicroTech controller opens the heating valve and sets a 10-minute timer. The MicroTech controller’s active alarm is “Freeze Problem.”

When the 10-minute timer expires, the controller begins checking the freezestat again. If the freezestat is open, the heating valve closes. If the freezestat closes again, the heating valve opens, and the 10-minute timer resets.

When the freezestat opens again, the “Freeze Prob” alarm automatically clears. This feature protects the coil and allows the system to start normally after a cold night.

### External Time Clock or Tenant Override

There are several methods of switching the rooftop unit between occupied and unoccupied operation. It can be done by the controller internal schedule, a network schedule, an external time clock, or a tenant override switch.

If the internal schedule or a network schedule is used, field wiring is not required.

An external time clock or a tenant override switch can be used by installing a set of dry contacts across terminals 101 and 102 on the field terminal block (TB2). When these contacts close, 24 V (ac) is applied to binary input MCB-DI3, overriding any internal or network schedule and placing the unit into occupied operation (provided the unit is not manually disabled). When the contacts open (24 V (ac) is removed from MCB-DI3) the unit acts according to the controller internal time schedule or a network schedule. Refer to the unit wiring diagrams for specific wiring termination details.

Figure 96: External Time Clock or Tenant Schematic

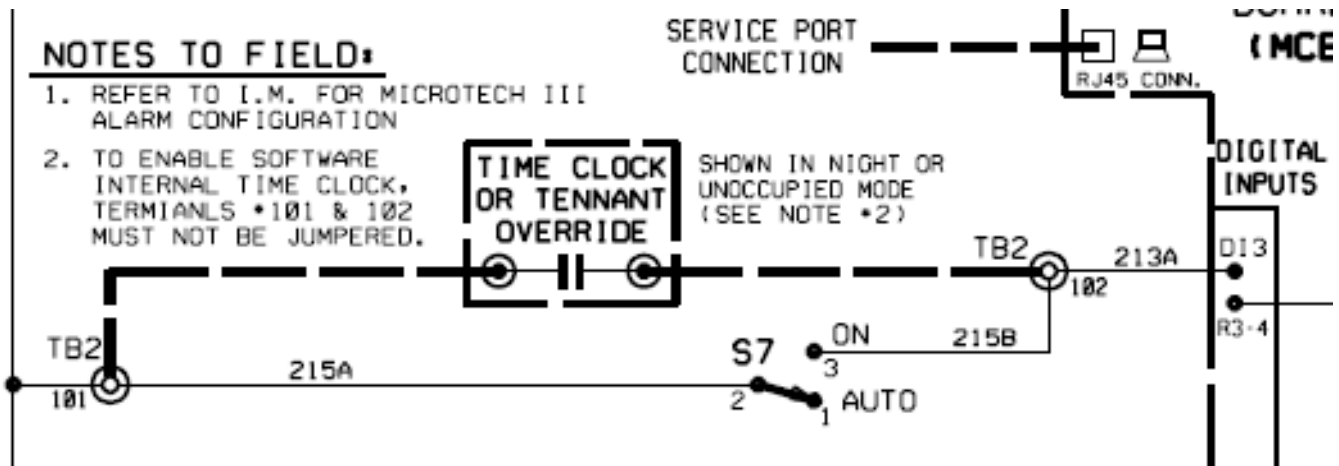

## Field Output Signals

The following outputs may be available for field connections to a suitable device.

### VAV Box Signal/Fan Operation Signal

Digital Output #10 (MCB-DO10) may be selected as either the Fan Operation output or the VAV output via the keypad. The VAV/Fan Pop selection can be selected by accessing the Unit Setup menu in the Extended Menu section.

### Fan Operation

The Fan Operation Output (MCB-DO10) supplies 24 V (ac) to terminal 116 on the field terminal block (TB2) when the output is on. To use this signal, wire the coil of a field supplied and installed 24 V (ac) pilot relay across terminals 116 and 117 on TB2. When this output is on, 24 V (ac) is supplied from the T3 control transformer through the output relay to energize the field relay. Refer to the as-built wiring diagrams.

The Fan Operation output is ON when the unit is not Off and when both the unit is OFF and airflow is detected. It is off when the unit is off and airflow is not detected.

### VAV Box Output

The VAV Box Output (MCB-DO10) supplies 24 V (ac) to terminal 116 on the field terminal block (TB2) when the output is on. To use this signal, wire the coil of a field supplied and installed 24 V (ac) pilot relay across terminals 116 and 117 on TB2. When this output is ON, 24 V (ac) is supplied from the T3 control transformer through the output relay to energize the field relay. Refer to the as-built wiring diagrams.

In the Heating state, the VAV Output is turned off to indicate that hot air instead of the normal cool air is being supplied to the VAV boxes. The VAV boxes are driven to their Heating Position when hot air is provided based on either the normally open or normally closed contacts of the VAV output. The VFD will continue to be controlled to maintain the desired duct static pressure. This output is also OFF when the unit is in the Startup or Recirculation states. If this output is in the Heat (OFF) position when the unit enters the Fan Only state or Minimum DAT Control state, the output remains off for an adjustable Post Heat Time (while the unit VFDs are driven to minimum speed) or until the VFD gets to its minimum speed if the Post Heat Time is set greater than 0. The Post Heat Timer can be adjusted via the keypad/display Timer Setting menu in the Extended Menus.

During unoccupied operation, the VAV Box Output is in the Cool (ON) position unless airflow is detected. When airflow is detected, it switches to the Heat (OFF) position.

Figure 97: Field Output Schematic

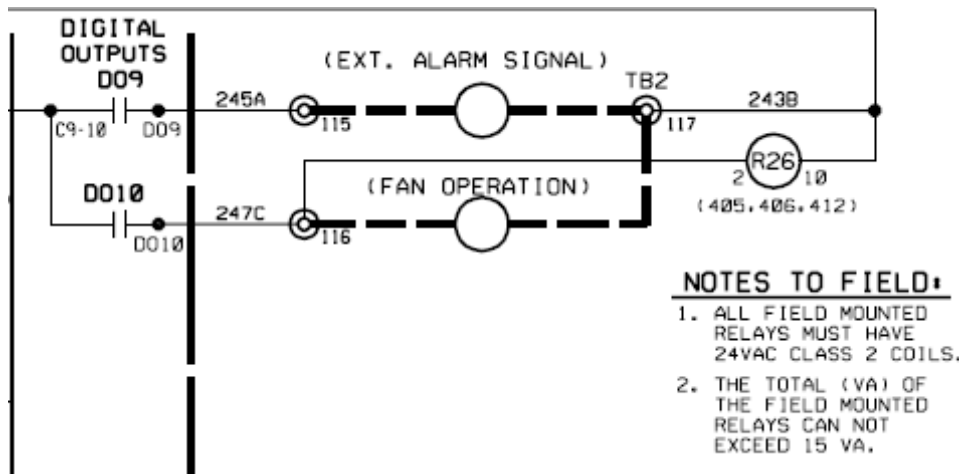

## Entering Fan Temperature Sensor

The entering fan temperature (EFT) sensor and an associated "Lo Airflow Problem" alarm are provided on VAV units with MicroTech control and gas or electric heat. The EFT sensor is located in the supply fan section of the unit at the supply air funnel.

Heat is disabled whenever the airflow is detected to be too low for safe heating operation. This condition is indicated when the supply air temperature exceeds the mixed air temperature by more than 60°F (16°C).

**NOTE:** This value is not always 60°F. It depends on whether the unit is gas or electric heat and on the burner/baffling arrangement on gas heat units.

In this case, a "Lo Airflow Problem" alarm is generated and heat is not enabled until the alarm is manually cleared. Refer to the operation manual supplied with the unit for information clearing alarms ([OM 920](#)).

## Duct High Pressure Limit

The duct high pressure limit control (DHL) is provided on all VAV units. The DHL protects the duct work, the terminal boxes, and the unit from over pressurization, which could be caused by, for example, tripped fire dampers or control failure.

The DHL control is factory set to open when the discharge plenum pressure rises to 3.5" wc (872 Pa). This setting should be correct for most applications; however, it is adjustable. Removing the front cover of the device reveals a scale showing the current setting. Turning the adjustment screw (located on the bottom of the device) adjusts the setting up or down.

If the DHL switch opens, digital input MCB BI 14 on the Main Control Board de-energizes. The MicroTech controller then shuts down the unit and enters the Off-Alarm state. The alarm must be manually cleared before the unit can start again. Refer to the operation manual supplied with your unit for more information on clearing alarms ([OM 920](#)).

## Variable Frequency Drive Operation

Refer to the vendor instructions supplied with the unit.

## Convenience Receptacle/Section Lights

A Ground Fault Circuit Interrupter (GFCI) convenience receptacle is provided in the main control box on all units. Both unit-powered and field-powered versions are offered.

To use the field-powered receptacle one of the following is required:

1. Connect a separate field-supplied 115 V power wiring circuit to the 115V field terminal block TB7, located in the main control box.
2. Select the factory powered outlet option at time of purchase.

Optional lights are available for certain sections in the unit. Each light includes a switch and convenience receptacle and is powered by the external 115V power supply connected to TB7.

## Optional Low Ambient Compressor Operation

### Fixed Speed Scroll Compressors

Daikin Applied's head pressure control operates in conjunction with FanTrol by modulating the motor speed of the last condenser fan of each refrigeration circuit in response to condenser pressure. By varying the speed of the last condenser fan of each refrigeration circuit, the VFD option allows mechanical cooling operation in ambient temperatures down to 0°F (-18° C). The VFD option senses refrigerant head pressure and varies the fan speed accordingly. When the pressure rises, the SpeedTrol increases the fan speed; when the pressure falls, SpeedTrol decreases the fan speed.

The VFD throttling range is 250 to 400 psig, fixed. The VFD fan motor is a three-phase motor, identical to the unit voltage (208 V to 575 V) and is controlled by a variable frequency drive (Figure 98). The variable frequency drive receives a signal from a pressure transducer and varies the condenser fan speed accordingly.

The pressure transducer is calibrated to provide a 1.0 to 5.0 V (dc) signal with a 8 to 30 V (dc) input, starting at 1.0 V (dc) @ 250 psig and up to 5.0 V (dc) @ 400 psig. In order to maintain an acceptable condensing pressure, the VFD will modulate the motor down to a minimum of 23 Hz, and will not allow operation below this frequency level. At, or above 400 psig, the VFD will operate the motor at 60 Hz. The control band between the two frequencies (23 Hz and 60 Hz) is a linear relationship with the condensing pressure as shown in (Figure 98).

The VFDs and pressure transducers are located in the control box mounted in the condensing section. Each refrigerant circuit is independent and has its own respective VFD and pressure transducer. The speedtrol option operates independently of the main unit controller. It is required for variable speed inverter compressors at 0°F ambient temperatures.

Figure 98: R-410A Speedtrol

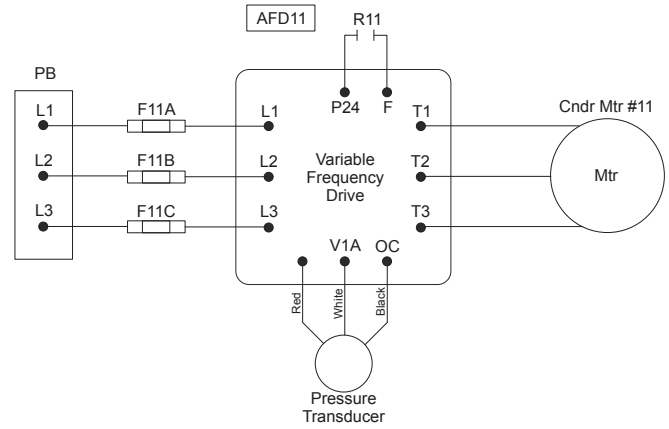
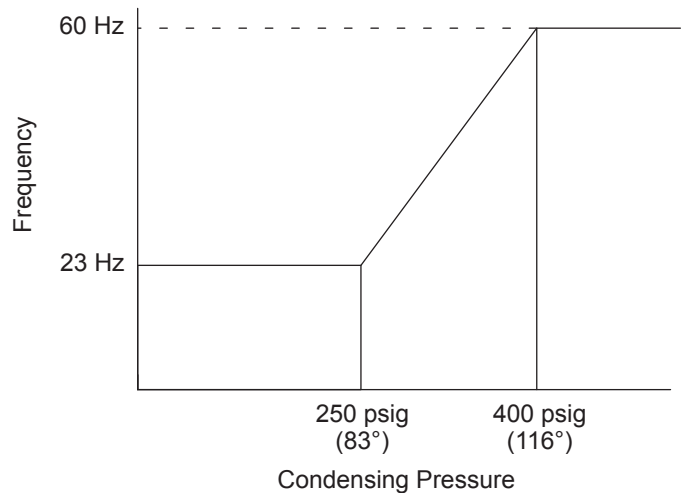

Figure 99: Speedtrol Operating Characteristics (for Fixed Speed Compressor Unit)



### Condenser Fan Operation for Variable Speed Compressor Option

Daikin Applied's head pressure control operates by modulating the motor speed of all the condenser fans in each refrigeration circuit in response to the condenser pressure. Each refrigerant circuit also contains a solenoid valve that blocks refrigerant flow to the upper half of the condenser coil, which effectively removes 50% of the condenser surface from the circuit for low load/low ambient conditions.

This option allows for mechanical cooling operation down to 0°F (-18°C). The VFD option senses refrigerant head pressure and varies the fan speed accordingly. When the pressure rises, the SpeedTrol increases the speed of the fans, when the pressure falls. SpeedTrol decreases the speed of the fans.

The VFD throttling range is 250 to 400 psig, fixed, with a corresponding fan speed range of 10Hz to 60Hz. The fan motor is a three-phase motor, identical to the unit voltage (208V to 460V) and is controlled by a variable frequency drive. The variable frequency drive receives a signal from a pressure transducer and varies the speed of the condenser fans accordingly.

The SpeedTrol arrangement for VFD compressors is also employing "Start-Stop control by Speed reference Level" in which the VFD will stop the condenser fan motors under certain conditions. If the head pressure were to fall below 250 PSIG with the condenser fans operating at minimum speed of 10Hz (possibly due to a low ambient or high wind condition) the VFD will shut down the condenser fans. The VFD will restart the condenser fans at 20 Hz if head pressure rises to a level above 250 PSIG. In addition to modulating fan speed, refrigerant solenoid valves are included in each refrigerant circuit. Operation of the solenoid valves is based on head pressure. If the average condensing pressure falls below 250 PSIG (83°F sat) for 60 seconds, the condenser solenoid valve closes, effectively removing 50% of the condensing surface. If the averaging condensing pressure rises above 350 PSIG (105°F sat) for 60 seconds, the condenser solenoid valve is opened, activating the entire condenser surface. The solenoid valves are disabled above an outdoor ambient of 80°F. The solenoid valves are in a normally open configuration.

Refer to [Figure 98](#) for wiring schematics of SpeedTrol. Refer to [Figure 100](#) and [Figure 100](#) for SpeedTrol operating characteristics.

Figure 100: Speedtrol Operating Characteristics (for Variable Speed Inverter Compressor Unit in °F)

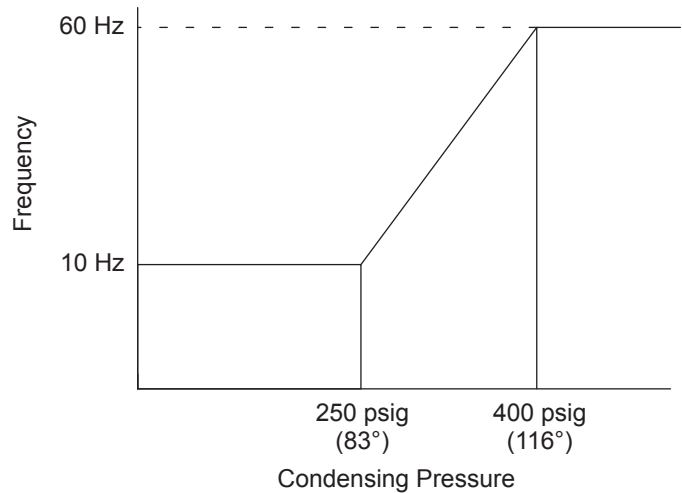
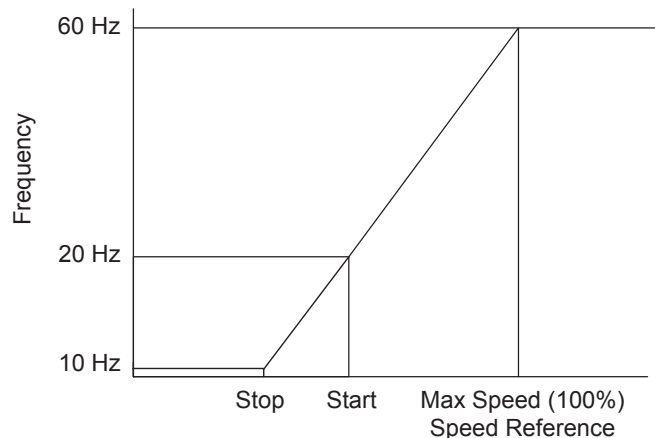

Figure 101: Speedtrol Operating Characteristics (for Variable Speed Inverter Compressor Unit with Start-Stop Control)





## DesignFlow™ Outdoor Air Damper Option

DesignFlow™ airflow measurement stations are located inside the louvered outdoor air intake doors between the intake louver and outside air dampers (Figure 102). Essentially, they consist of a vane that is repositioned by airflow, the amount of rotation indicating the amount of airflow. They are calibrated precisely at the factory and no further calibration is required. However, a leveling adjustment is required in the field so that the DesignFlow unit is in the same orientation as when it was factory calibrated. See “DesignFlow Station Startup” below.

The rotational position of the DesignFlow unit vane is translated into CFM by the microprocessor in the MicroTech control system. The position of the vane is determined by two things—the force of the airflow impacting the vane and the gravitational effect on the vane. Gravity is the only factor at the lower CFM end of the range. On a correctly leveled unit, this gravitational effect will be the same as when the unit was calibrated in the factory.

Accurately leveling a station involves applying a precise mechanical force against the vane. This force should cause the vane to move to a specific position if the DesignFlow unit is correctly leveled.

Figure 102: DesignFlow Station

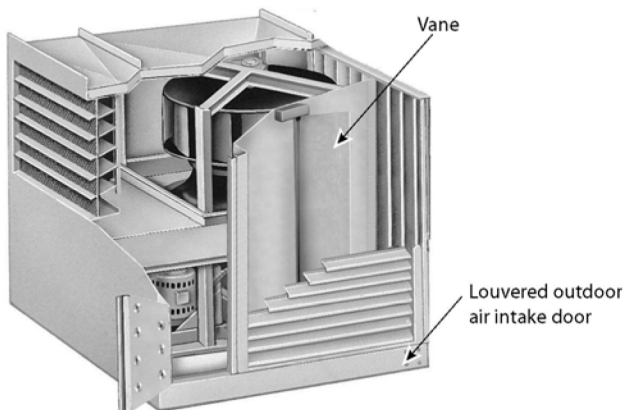

### DesignFlow Station Startup

Before initial startup of the rooftop unit, carry out the following procedure on both the right-hand (control panel side) and left-hand (side opposite the control panel) DesignFlow station vanes (see Figure 102).

1. Verify that power is supplied to the unit's MicroTech control system. The DesignFlow startup procedure cannot be completed without use of the MicroTech controls.
2. Unlock and open the louvered outdoor air intake door on the side of the unit (see Figure 102).
3. The swinging vane on the measurement station is locked in place for shipment. Unlock it by removing the two shipping screws. One is located one inch from the top of the vane and the other one inch from the bottom of the vane. Both are about eight inches in from the outer edge of the vane.
4. Examine the station for shipping damage. Manually rotate the vane and verify that it does not rub against anything.
5. Manually hold the vane closed against the mechanical stop at the top of the assembly. Then, read the current vane leveling position on the MicroTech keypad/display.

Do this by viewing the *LH Lvl Pos=* or *RH Lvl Pos=* parameter in the Min OA setup menu. The *LH Lvl Pos=* parameter indicates the current position of the vane for the left-hand DesignFlow station (side opposite the control panel). The *RH Lvl Pos=* parameter indicates the current position of the vane for the right-hand DesignFlow station (control panel side).

**Important:** Wait several seconds until the value on the keypad stabilizes before taking the reading. For detailed information regarding operation and navigation through the unit keypad, refer to [OM 920](#).

6. Confirm the value of the reading. Ideally, it should read close to 20.00 (19.50 to 20.50 is acceptable). If the reading is out of range, loosen the screws fixing the mechanical stop at the top of the assembly, make a small adjustment, and recheck until the reading is in the specified range.

**NOTE:** Generally, adjustments should not be necessary.

7. Locate the leveling component kit, which is shipped with the unit, in the unit main control panel.
8. Duct tape the fulcrum alignment plate to the bottom corner of the vane (see Figure 103) aligning it as follows:
  - a. The bottom edge of its notches should be flush with the bottom edge of the vane.
  - b. The side of one notch should be even with the bend near the outer edge of the vane.
  - c. The plate should be flat against the outer surface of the vane.

9. Locate and install the fulcrum used in the leveling procedure as follows (see Figure 103):
  - a. Wipe the bottom of the louver door where the fulcrum will be located so that the duct tape will stick to it.
  - b. Pre-apply duct tape to the top surface of the bottom portion of the fulcrum, extending it about one inch beyond the edges on three sides.
  - c. With the alignment plate taped to the vane and the vane in the zero airflow position, locate the fulcrum parallel to and against the alignment plate.
  - d. Once the fulcrum is in position, press the duct tape extensions down to hold the fulcrum in place.
  - e. Remove the alignment plate after installing the fulcrum.

**NOTE:** The zero airflow position is when the vane is swung away from the back wall and gently resting against its stop.

10. Close and latch the louvered intake door.
11. Remove the cover from the access opening in the bottom blade of the outdoor air intake louver (see Figure 106).
12. Verify that the unit fans are off and that the outdoor air dampers are closed. If there is a wind, cover the outdoor air louvers with poly film, cardboard, or other suitable material to prevent adverse readings due to wind.
13. Rest the leveling weight assembly on the fulcrum, as shown in Figure 104, so that:
  - a. Its bottom two thumbscrews rest on the top edge of the fulcrum.
  - b. Its top thumbscrew rests against the vertical alignment mark on the vane.

**NOTE:** The alignment mark is located 0.50 inch in from the bend on the outer edge of the vane. It intersects with a hole located one inch up from the bottom outer edge of the vane.

14. Set up the leveling test as follows:
  - a. While holding the weight so it stays on the fulcrum, manually rotate the vane to the wide-open position, manually return it to the zero CFM position, and gently release the vane.
  - b. Locate the leveling weight assembly so its contact point is against the vertical mark on the vane.
  - c. While the weight assembly teeters on the fulcrum, gently rap the base frame to slightly vibrate the assembly and encourage the vane to seek its equilibrium point.
15. Read the current *LH Lvl Pos=* (or *RH Lvl Pos=*) parameter in the Min OA Setup menu on the keypad/display. These parameters vary from 20% to 80% depending on the position of the DesignFlow vane.

16. If the value indicated by the *LH Lvl Pos=* (or *RH Lvl Pos=*) parameter is not within the range of 22.56% to 23.02% (22.79% is ideal), adjust the level of the DesignFlow unit using the procedure described in "Making Level Adjustments" below.
17. When the *LH Lvl Pos=* (or *RH Lvl Pos=*) value is in range, remove the fulcrum and leveling weight assembly and replace the access opening cover in the louvered door.

**Figure 103: Tape Fulcrum Alignment Plate to Vane**

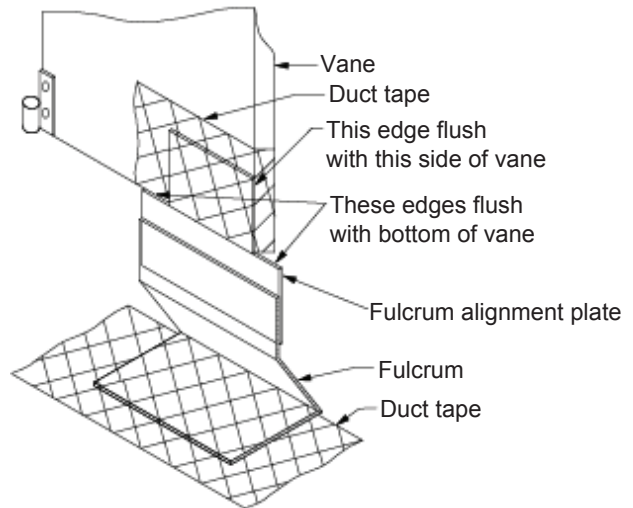

**Figure 104: Place Leveling Weight on Fulcrum**

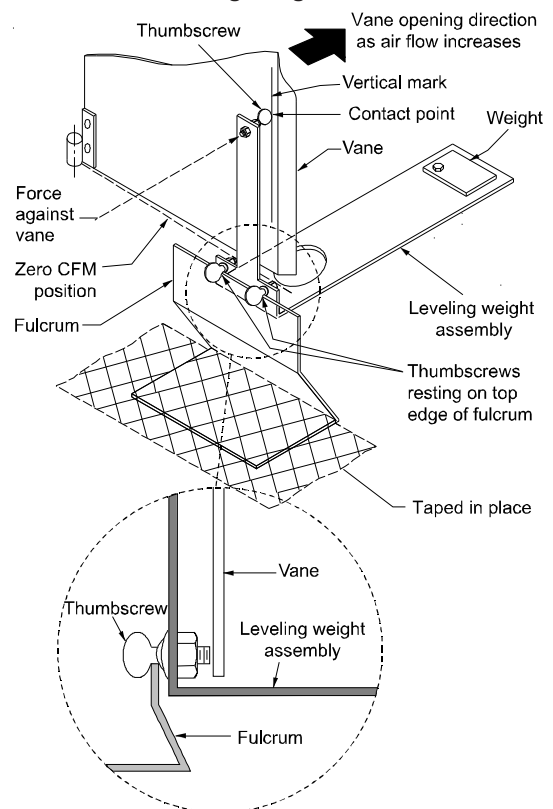

## Making Level Adjustments

The DesignFlow unit is mounted so that it pivots at the top when three lock nuts are loosened, two at the top and one at the bottom of the assembly (see [Figure 105](#)). Leveling the unit involves precisely pivoting the assembly with a known force applied to the vane until the vane opens to a specific position.

If after performing Steps 13 through 15 above, the vane does not come to rest within the specified range, carry out these steps:

1. Unlock and open the louvered outdoor air intake door on the side of the unit.
2. Loosen the two 1/4-20 NC lock nuts at the top of the DesignFlow frame. (See [Figure 105](#).)
3. Close and lock the intake door.
4. Remove the cover from the access opening in the bottom blade of the outdoor air intake louver (see [Figure 106](#)).
5. Loosen the 1/4-20 NC lock nut in the slotted hole at the bottom of the DesignFlow frame. (See [Figure 107](#).)
6. If the *LH Lvl Pos=* (or *RH Lvl Pos=*) value obtained in step 15 above is HIGHER than the specified range, move the bottom of the DesignFlow frame closer to the outdoor air dampers (away from the back end of the unit). Do this by turning the long adjuster nut to increase the L dimension in [Figure 107](#).

If the *LH Lvl Pos=* (or *RH Lvl Pos=*) value obtained in step 15 above is LOWER than the specified range, move the bottom of the DesignFlow frame away from the outdoor air dampers (toward the back end of the unit). Do this by turning the long adjuster nut to decrease the L dimension in [Figure 107](#).

**NOTE:** If the necessary adjustment cannot be made using the long adjuster nut, reposition the two 1/4-20 NC jam nuts on the threaded rod to make larger adjustments (see [Figure 107](#)).

7. When finished making the adjustments, tighten the 1/4-20 NC lock nut in the slotted hole at the bottom of the DesignFlow frame. (See [Figure 107](#).)

**NOTE:** Make sure the leveling weight's top thumbscrew is still against the vertical alignment mark on the vane.

8. Gently rap the base frame to slightly vibrate the assembly to encourage the vane to seek its equilibrium point.
9. Recheck the vane position compared to the range specified in Step 16 above. Readjust the level as necessary.

**NOTE:** If large adjustments are required to correctly level the vane assembly, before rechecking the level, relocate the fulcrum as described in Step 9 in [DesignFlow Station Startup on page 89](#).

10. When the level is correct, unlock and open the louvered outdoor air intake door on the side of the unit and tighten the two 1/4-20 NC lock nuts at the top of the DesignFlow frame. (See [Figure 105](#).)
11. Close and lock the air intake door.
12. Recheck the vane position and readjust the level as necessary.
13. When the vane position is correct, remove the fulcrum and replace the access opening cover in the louvered door.

**Figure 105: DesignFlow Frame**

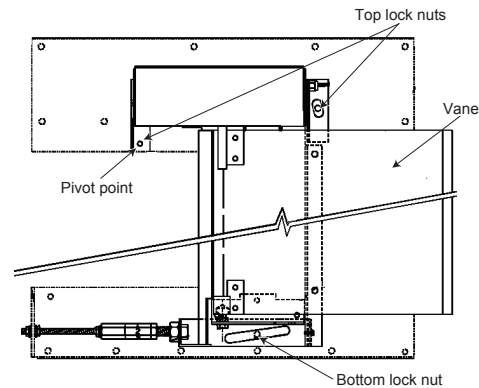

**Figure 106: Remove Covers from Access Opening**

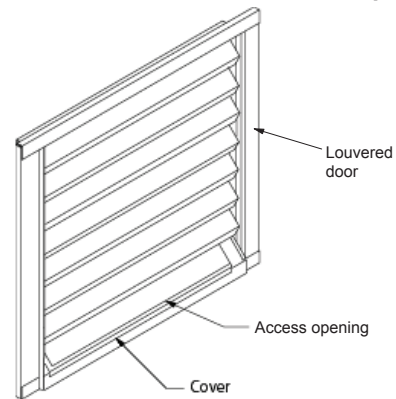

**Figure 107: Leveling Adjustment**

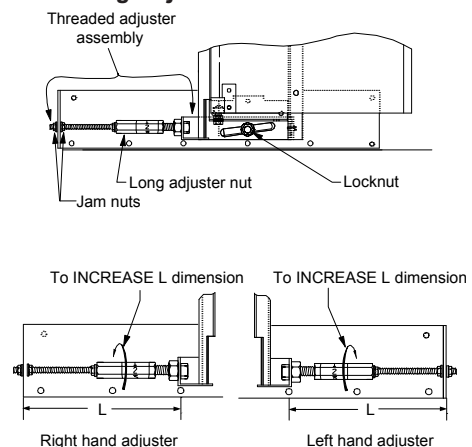

## Propeller Exhaust Fan Option

Economizer units may include propeller exhaust or centrifugal return fan options. This section covers maintenance and operating instructions for the propeller exhaust option. Centrifugal return fan construction, maintenance and operation is similar to that for supply fans and covered in other sections of this manual.

**Figure 108: Two Fans with Back Return Shown**

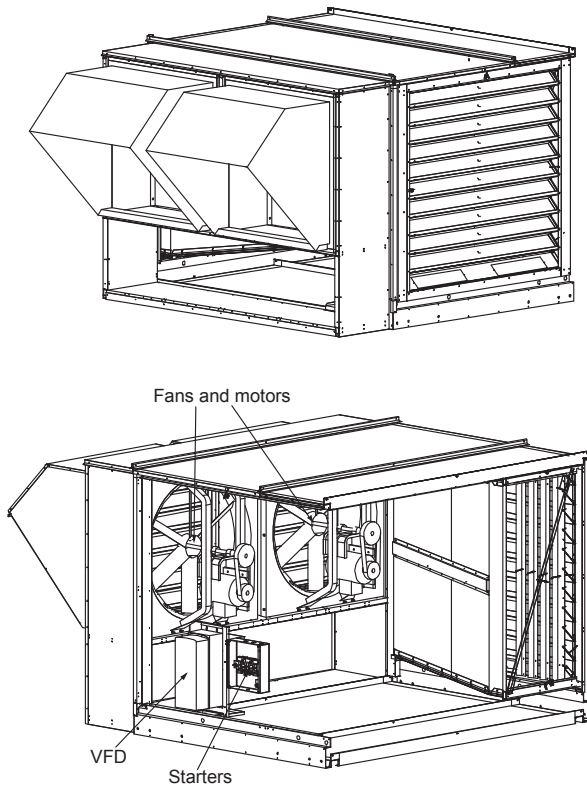

### Prestarting Checks

Check all fasteners and set screws for tightness. This is especially important for bearing set screws.

The propeller should rotate freely and not rub on the fan panel venturi. Rotation direction of the propeller should be checked by momentarily turning the unit on. Rotation should be in the same direction as the rotation decal affixed to the unit or as shown in [Figure 109](#). For three-phase installations, fan rotation can be reversed by simply interchanging any two of the three electrical leads.

The adjustable motor pulley is preset at the factory for the specified fan RPM. Fan speed can be increased by closing or decreased by opening the adjustable pulley. Two or three groove variable pitch pulleys must be adjusted an equal number of turns open. Any increase in fan speed represents a substantial increase in horsepower required from the motor. Always check motor load amperage and compare to name plate rating when changing fan speed.

**Figure 109: Fan Rotation**

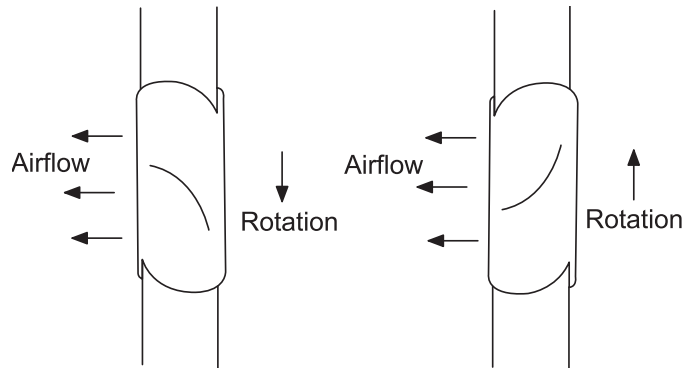

Once the fan is put into operation, set up a periodic maintenance program to preserve the reliability and performance of the fan. Items to include in this program are:

- Belts
- Bearings
- Fasteners
- Setscrews
- Lubrication
- Removal of Dust/Dirt

### Damper Counterbalance Adjustment

The following instructions should be followed when attempting to maximize the counterbalance effect on the dampers. Be aware that when the balance setting is highly sensitive, friction wear and contamination will have an adverse effect to the operation of the damper. The sensitivity of the counterbalance should only be set to meet the application requirements. The damper must be mounted square and plumb and operate freely before any weight adjustments are performed.

Adjustment #1 will effect the balance of the blades in the open position. Adjustment #2 will effect the balance of the blades in the closed position along with a small change to the open position balance.

If the damper blades do not achieve full open position under airflow and you want them to open further or all the way, then adjustment #1 will need to be performed. If the damper blades do not open completely and adjustment #1 has been addressed, then more weight is required.

If the airflow through the damper is light and the blades only slightly move from the closed position, then adjustment #2 and #1 are required.

**Adjustment #1:**

Moving the weight stack along the length of the mounting bracket slot (Figure 110) will effect the full open balance of the blade assembly. Moving the weights further away from the blade pivot point will cause the blades to become more balanced so that at some point, and with enough weight, the blades would remain open. Care must be taken to ensure that when the weights are moved outward from the blade pivot point they will not interfere with the adjacent blade when the blades close. Moving the weights back towards the blade pivot point will allow the blades to close.

**Adjustment #2:**

The damper is assembled with the counterbalance weights and bracket installed such that, when the blades are closed, the counterbalance weights and bracket are positioned directly in line with the blade pivot points. This position of the weights will provide a slight load that will hold the blades in the closed position. To reduce this load, the counterweight-mounting brackets can be bent (Figure 110) away from the adjacent blade surface. Bending the counterweight mounting brackets will move the counterweight stack behind the blade pivot point and therefore allow the blades to start opening at lower airflow rates. This adjustment should be performed in small increments since the blades will not fully close if the brackets are bent to far.

**NOTE:** Performing adjustment #2 will have a small effect on adjustment #1. Therefore, if adjustment #1 is critical, then adjustment #1 may need to be repeated.

**Figure 110: Counterbalance Adjustment**

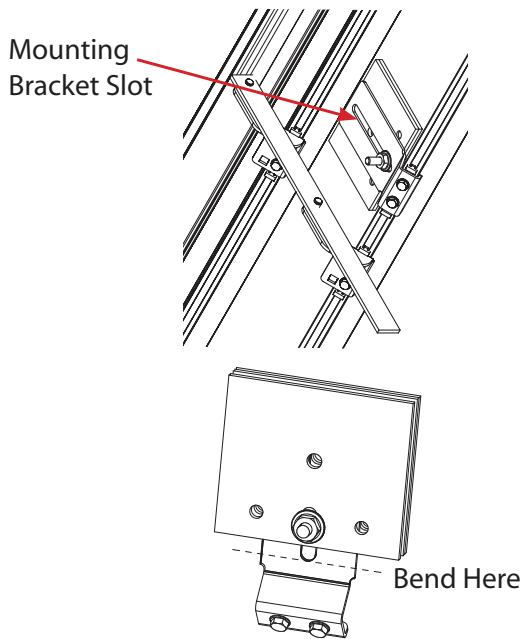

**Belts**

Premature belt failures are frequently caused by improper belt tension (either too tight or too loose) or misaligned pulleys. The proper tension for operating a V-belt is the lowest tension at which the belts will not slip at peak load conditions. For initial tensioning, the proper belt deflection half way between pulley centers is 1/64" for each inch of belt span. For example, if the belt span is 64 inches, the belt deflection should be one inch using moderate thumb pressure at midpoint of the drive, See Figure 111.

Check belt tension two times during the first 24 hours of operation and periodically thereafter. To adjust belt tension, simply loosen four fasteners (two on each side of the motor plate) and slide the motor plate away from the fan shaft until proper belt tension is attained. On some fans, fasteners attaching the motor to the motor plate must be loosened in order to adjust the belt.

It is very important that the drive pulleys remain in proper alignment after adjustments are made. Misalignment of pulleys results in premature belt wear, noise, vibration, and power loss. See Figure 112.

**Figure 111: Belt Adjustment**

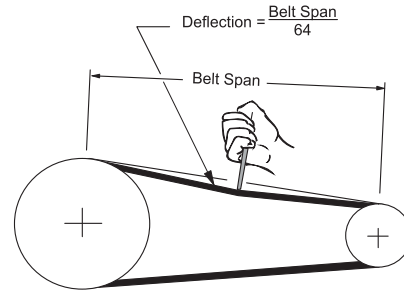

**Figure 112: Drive Pulley Alignment**

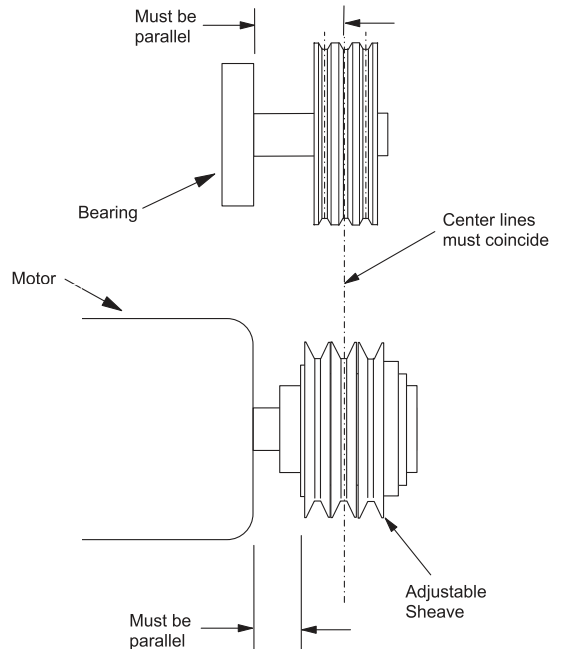

**Table 19: Propeller Exhaust Fan Troubleshooting**

Problem	Cause	Corrective Action
Reduced Airflow	System resistance is too high.	<ul style="list-style-type: none"> <li>• Check backdraft dampers for proper operation</li> <li>• Remove obstructions in ductwork</li> <li>• Clean dirty filters</li> <li>• Check for adequate supply for air exhaust fans or exhaust air for supply fans</li> </ul>
	Unit running backwards.	See <a href="#">Prestarting Checks on page 92</a>
	Fan speed too low.	Increase fan speed
	Excessive dirt on propeller.	Clean propeller
Excessive Noise	Bearings	<ul style="list-style-type: none"> <li>• Tighten bearing collars and setscrews</li> <li>• Lubricate bearings</li> <li>• Replace defective bearings</li> </ul>
	V-Belt drive	<ul style="list-style-type: none"> <li>• Tighten pulleys on motor shaft and fan shaft</li> <li>• Adjust belt tension</li> <li>• Align pulleys</li> <li>• Replace worn belts or pulleys</li> </ul>
	Excessive vibration	<ul style="list-style-type: none"> <li>• Clean dirt build-up from propeller</li> <li>• Check all setscrews and fasteners for tightness</li> <li>• Check for worn bearing</li> <li>• Correct propeller imbalance</li> <li>• Check for loose dampers, guards or ductwork</li> </ul>
	Defective motor	Replace motor.

**Figure 113: Propeller Exhaust Fan Replacement Parts List**

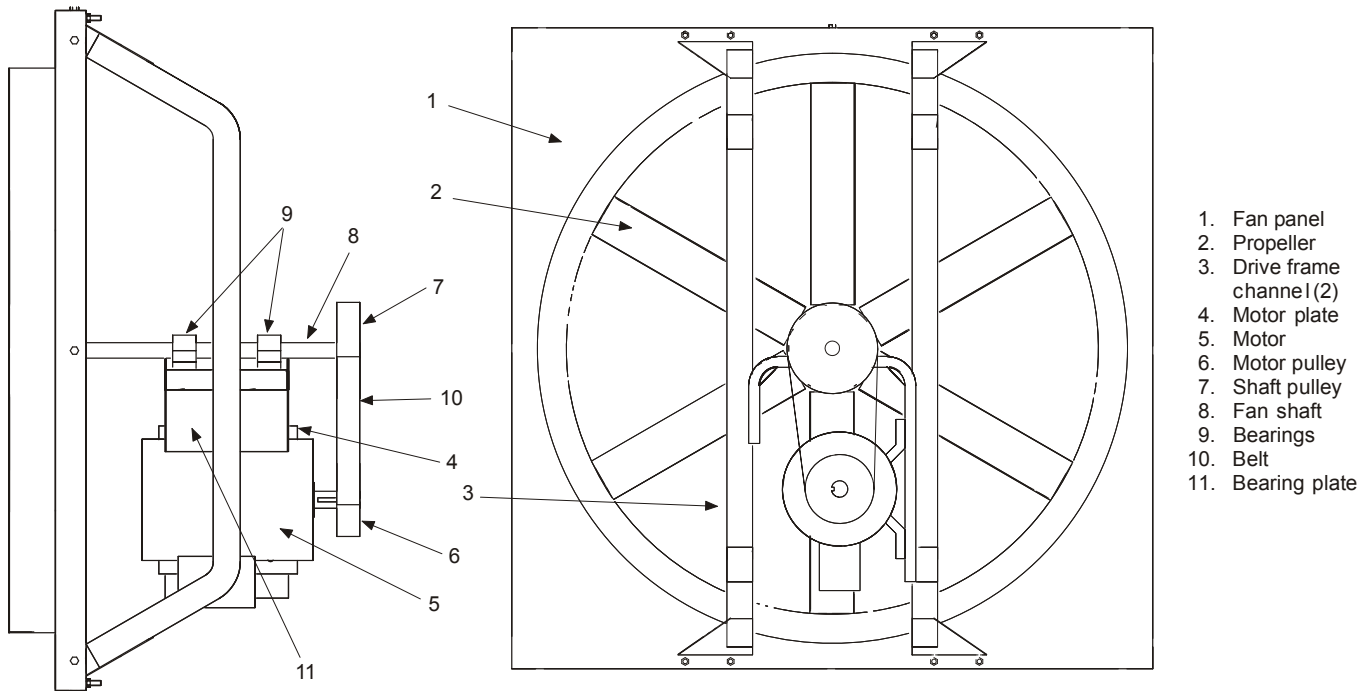

## Bearings

Bearings are the most critical moving part of the fan; inspect them at periodic intervals. Check locking collars, set screws, and fasteners that attach bearings to the bearing plate for tightness. In a clean environment and temperatures above 32°F/below 200°F, lubricate fan shaft bearings with grease fittings semiannually using a high quality lithium-based grease. If unusual environmental conditions exist temperatures below 32°F/above 200°F, moisture or contaminants, more frequent lubrication is required.

With the unit running, add grease very slowly with a manual grease gun until a slight bead of grease forms at the seal. Be careful not to unseat the seal by over lubricating or using excessive pressure. Bearings without grease fittings are lubricated for life.

## Fasteners and Setscrews

Any fan vibration has a tendency to loosen mechanical fasteners. A periodic inspection should include checking all fasteners and set screws for tightness. Pay particular attention to setscrews attaching the propeller to the shaft and the shaft to the bearings. Loose bearing set screws lead to premature failure of the fan shaft.

## Lubrication

Refer to “Bearings” for bearing lubrication. Many fractional horsepower motors installed on the smaller fans are lubricated for life and require no further attention. Oil motors equipped with oil holes in accordance with the manufacturer’s instructions printed on the motor. Use a high grade SAE 20 machine oil and use caution not to over lubricate. Grease motors supplied with grease fittings according to directions printed on the motor.

## Removing Dust/Dirt

Thoroughly clean the exterior surface of the motor, fan panel, and entire propeller periodically. Dirt can clog cooling openings on motor housings, contaminate bearing lubricant, and collect on propeller blades causing severe imbalance if left unchecked. Use caution and do not allow water or solvents to enter the motor or bearings. Under no circumstances should motors or bearings be sprayed with steam or water.

## Exhaust Fan ON/OFF Control

The exhaust fans are turned on and off based on building static pressure, outdoor air damper position, and discharge fan capacity. Exhaust fans do not have to always run while the supply fan is on, as does a return fan. They are turned on and off through output MCB-B02 on the Main Control Board. For detailed information on Propeller Exhaust Fan Control, see the operation manual supplied with the unit ([OM 920](#)).

## Exhaust Fan Troubleshooting

[Table 19](#) provides guidelines for troubleshooting problems with the propeller exhaust fan options. A list of parts is provided in [Figure 113](#).

## Ultraviolet Lights Option

When this option is employed, ultraviolet C light bathes the moist surfaces on the coil and drain pan, killing most microorganisms that can grow there.

Typically, ultraviolet lights are installed on the leaving side of the cooling coils in the unit. Each light module is mounted on a rail and is removable for convenient bulb replacement.

UV Light Power Disconnect switches (two per door) are factory installed on every door that allows a direct line of sight to the UV lamps when opened. These switches are designed to prevent UV exposure when cabinet doors are opened and must not be disabled.

A viewing window near the UV lights allows viewing to determine if the lights are energized. The viewing windows use specially designed glass that blocks harmful UV light.

**Figure 114: Typical Ultraviolet Light Installation**

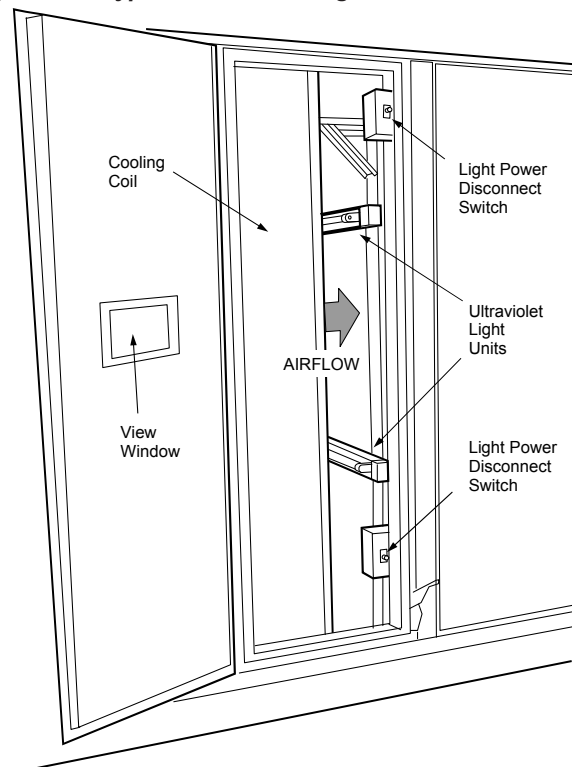

# Ultraviolet Light Operation

Refer to the wiring schematic below. 115 V (ac) power for the UV lights is provided by control circuit transformer T1. The lights operate whenever the unit is powered, system switch S1 is closed, and all doors with door power disconnect switches are closed. To turn the lights off, disconnect power to the entire unit, or open system switch S1.

The normally open disconnect switches are wired in series in a circuit that supplies 24 V (ac) to the coil of relay R45. When all doors are closed, relay R45 is energized, and its normally open contacts (in series with system switch S1) provide 115 V (ac) to the UV lights.

Figure 115: Typical Ultraviolet Light Wiring Schematic

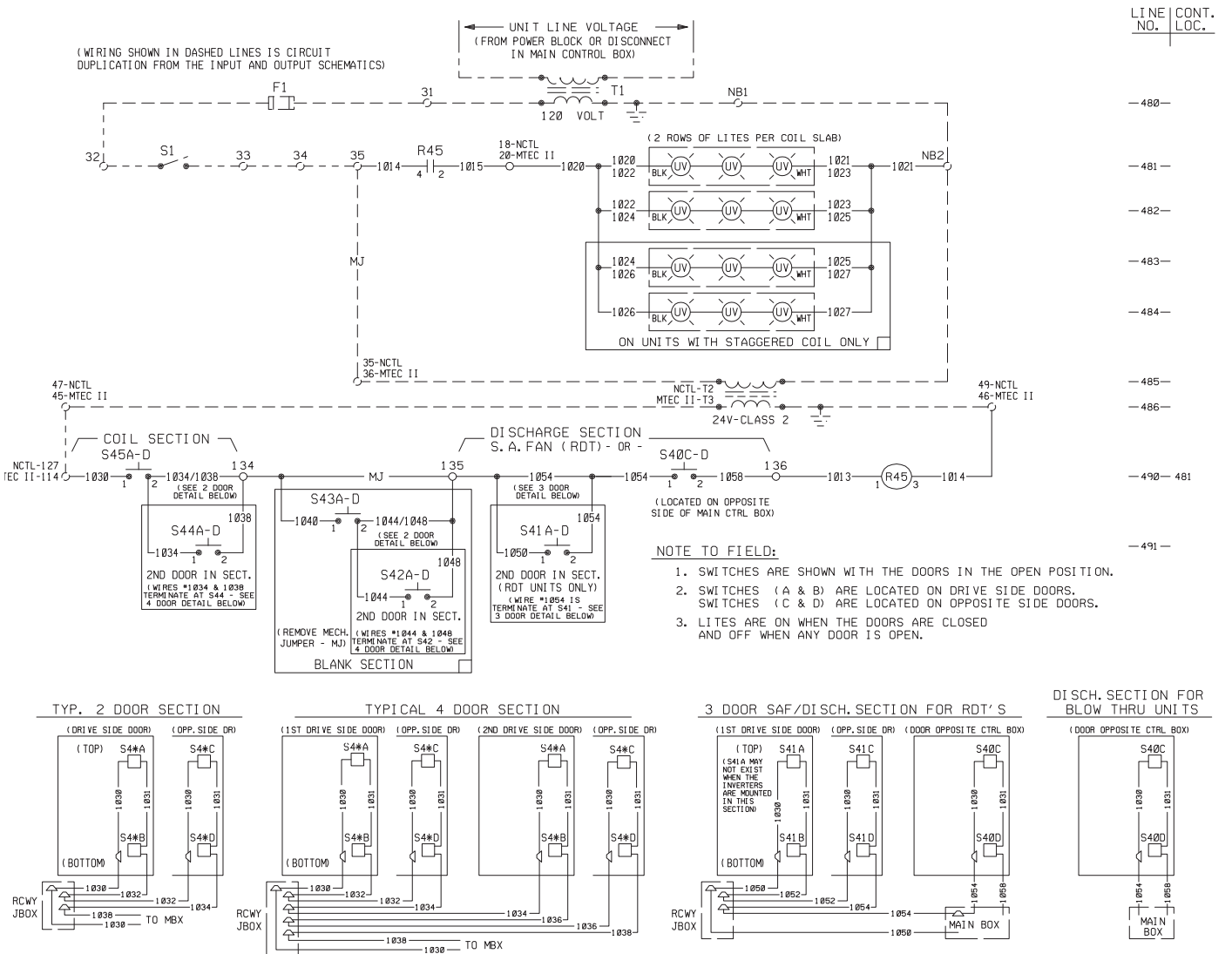



## MicroTech Remote User Interface for Daikin Applied Rooftop and Self-Contained Systems

In addition to the unit-mounted user interface provided with MicroTech controls, Daikin Applied applied rooftop systems and indoor vertical self-contained systems can be equipped with a remote user interface that handles up to eight units per interface. The remote user interface provides convenient access to unit diagnostics and control adjustments, without having to access your roof or mechanical rooms located on each floor.

Each remote user interface offers the same functionality as its unit-mounted counterpart, including:

- Push-and-roll navigation wheel with an 8-line by 30 character display format.
- Digital display of messages in English language.
- All operating conditions, system alarms, control parameters and schedules are monitored.

### Features

- Can be wired up to 700 meters from units for flexibility in placing each remote user interface within your building.
- Unit and remote user interfaces are both active.

**Figure 116: Remote User Interface**

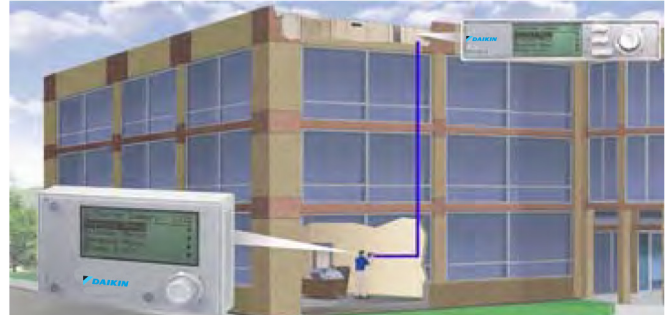

**Figure 117: Process Bus Wiring Connections**

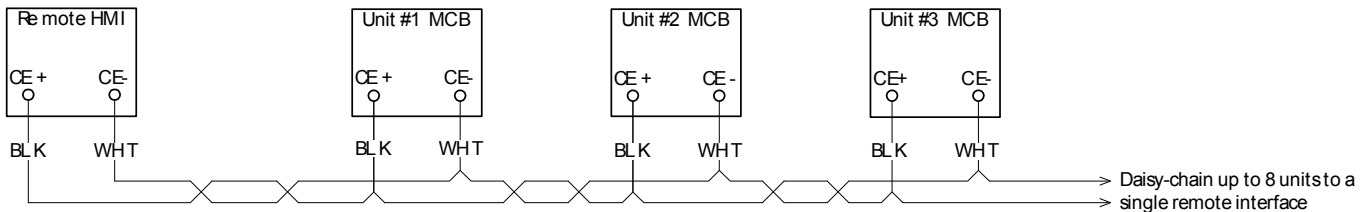

**Figure 118: Specifications and Connections**

**Interface**

Process Bus	Up to eight interfaces per remote
Bus connection	CE+, CE-, not interchangeable
Terminal	2-screw connector
Max. length	700 m
Cable type	Twisted pair cable; 0.5...2.5 mm2

**Display**

LCD type	FSTN
Dimensions	5.7 W x 3.8 H x 1.5 D inches (144 x 96 x 38 mm)
Resolution	Dot-matrix 96 X 208 pixels
Backlight	Blue or white, user-configurable

**Environmental Conditions**

Operation	IEC 721-3-3
Temperature	-40 to 70 °C
Restriction LCD	-20 to 60 °C
Humidity	<90% r.h. (no condensation)
Air pressure	Min. 700 hPa, corresponding to Max. 3,000 m above sea level



**Cover Removal**

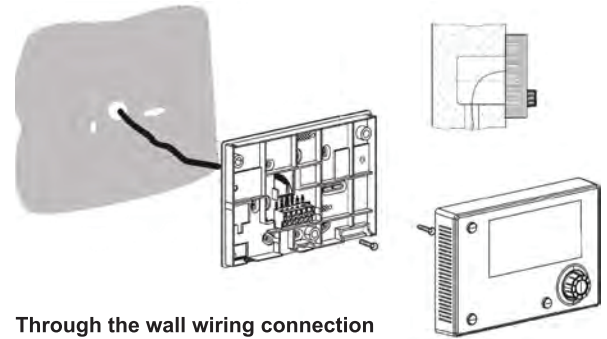
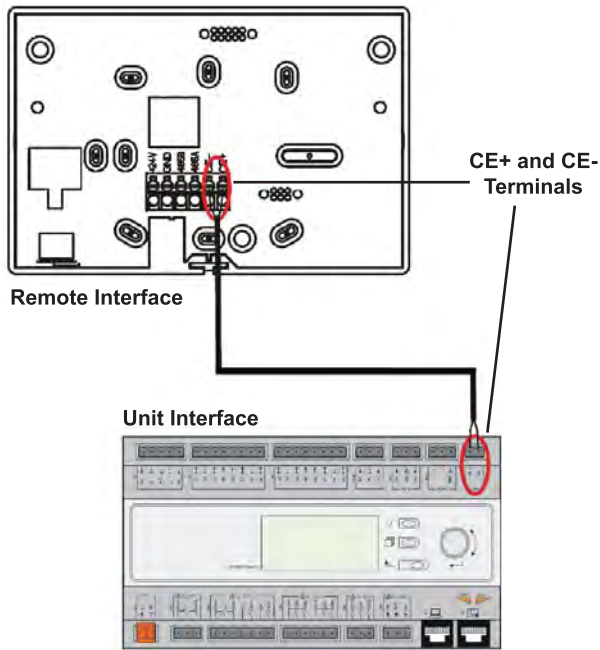

**Through the wall wiring connection**

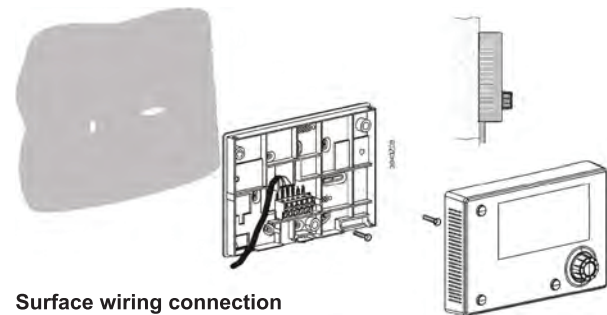

**Surface wiring connection**

## VFD Compressor Operation

When a RTU is equipped with the VFD compressor option there are two refrigeration circuits, one VFD controlled compressor with up to 3 fixed speed compressors depending on unit model. The VFD compressor must always be the “lead” circuit or first one on and last one off.

VFD compressor modulation is controlled by an analog signal (0 – 10 Vdc) from the unit controller. Refer to [Figure 119](#). The minimum VFD compressor speed is 25 rps (1500 rpm) and the maximum VFD compressor speed is 100 rps (6000 rpm), but the minimum and maximum limits may vary depending on operating conditions and unit model size.

The VFD compressor is a 4 pole motor design that operates off a frequency signal from the VFD between 50Hz and 200Hz.

At Start-up the VFD compressor will automatically ramp up to 50 rps for first 10 seconds for lubrication requirements.

Refer to [page 88](#) on condenser fan/head pressure regulation with VFD compressors.

Crankcase heating for VFD Compressor models VZH-088 & VZH-117 is performed by the VFD via DC-holding current through the motor windings. The VZH-170 compressor requires the use of an external banded heater.

VFD compressor modulation is additionally monitored and adjusted in order to maintain operation within the approved compressor operating envelope.

If the VFD compressor were to become inoperative, the unit can to continue to operate on the remaining fixed speed compressors until the unit can be serviced.

When the VFD compressor is at its maximum speed and more capacity is required, the available fixed compressor with the fewest run hour total is started while the VFD compressor is reduced to minimum speed at which point it resumes modulating to maintain the discharge temperature. When the VFD compressor is at its minimum speed and less capacity is required the fixed compressor with the highest run hour total is stopped while the VFD compressor is increased to maximum speed at which point it resumes modulating to maintain discharge temperature.

**Table 20: VFD Compressor Modulation Ranges**

RPS/RDT / Unit Model	VFD Modulation Range					LoOilBoostRps/ LoOilBoostV*	HiOilBoostRps/ HiOilBoostV*
	VFD Min Rps/ VFD Min V	VFD Max rps			VFD Comp Only VFDMaxRps/ VFDMaxV		
		VFD and Fixed Comp(s) On					
		1 Fixed On VFD1MaxRps/ VFD1MaxV	2 Fixed On VFD2MaxRps/ VFD2MaxV	3 Fixed On VFD3MaxRps/ VFD3MaxV			
016	25 rps / 0 Vdc	55 rps / 4.0 V	NA	—	100 rps / 10.0 V	70 rps / 6.0 V	100 rps / 10.0 V
021	25 rps / 0 Vdc	70 rps / 6.0 V	NA	NA	100 rps / 10.0 V	70 rps / 6.0 V	100 rps / 10.0 V
026	25 rps / 0 Vdc	85 rps / 8.0 V	NA	NA	100 rps / 10.0 V	70 rps / 6.0 V	100 rps / 10.0 V
031	25 rps / 0 Vdc	70 rps / 6.0 V	NA	NA	100 rps / 10.0 V	70 rps / 6.0 V	100 rps / 10.0 V
042	25 rps / 0 Vdc	100 rps / 10.0 V	95 rps / 9.33 V	NA	100 rps / 10.0 V	70 rps / 6.0 V	100 rps / 10.0 V
045	25 rps / 0 Vdc	75 rps / 6.7 V	75 rps / 6.7 V	NA	75 rps / 6.7 V	70 rps / 6.0 V	75 rps / 6.7 V
051	25 rps / 0 Vdc	85 rps / 8.0 V	85 rps / 8.0 V	NA	85 rps / 8.0 V	70 rps / 6.0 V	85 rps / 8.0 V
063	25 rps / 0 Vdc	95 rps / 9.33 V	95 rps / 9.33 V	NA	95 rps / 9.33 V	70 rps / 6.0 V	95 rps / 9.33 V
074	25 rps / 0 Vdc	70 rps / 6.0 V	50 rps / 3.3 V	100 rps / 10.0 V	100 rps / 10.0 V	70 rps / 6.0 V	100 rps / 10.0 V

\* High and Low Oil Boost are explained on [page 101](#)

**Figure 119: VFD Compressor Modulation Signal**

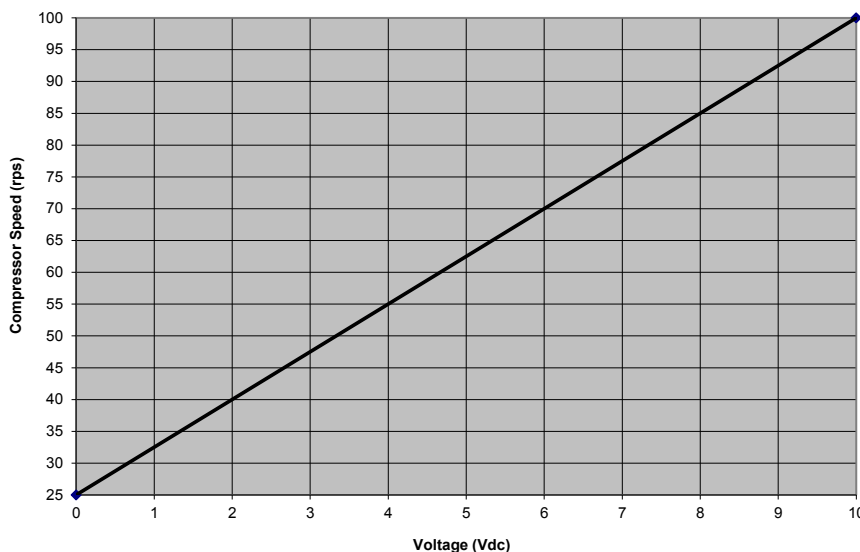

## VFD Compressor Control

Control of the VFD compressor is accomplished with a digital output enable signal and a 0-10VDC analog modulating control signal.

### General VFD Compressor Start Sequence

On a call for VFD compressor operation the VFD enable output is energized (on) and the 0-10VDC analog control signal is set to 3.33VDC (50 rps) for 10 seconds. During this 10 second initial period the VFD compressor's internal logic ramps the compressor to 50 rps to insure compressor startup oil lubrication. After 10 seconds the VFD compressor control signal begins modulation to maintain the cooling discharge set point.

**NOTE:** In addition to enabling VFD compressor operation the VFD enable output is used to energize the liquid line drop solenoid on the VFD circuit and also starts the auxiliary ventilation fans in the VFD compressor panel.

### Compressor Stage Up Transition

When the VFD compressor has been operating at maximum capacity for the cooling stage time period and there is a call for more cooling capacity the following transition sequence is followed when staging up.

During each fixed compressor stage UP sequence, the VFD compressor speed is reduced to its minimum (25 rps) as a fixed speed compressor is turned on. Note that the VFD compressor speed range is extended for these staging points to assure smooth transition and to minimize capacity gaps. Typically, the VFD compressor is overdriven (higher speed than normal full load rating speed) before staging up a fixed compressor. The VFD is held at minimum speed for 30 seconds before normal modulation resumes.

### Compressor Stage Down Transition

When the VFD compressor has been operating at minimum capacity for the cooling stage time period and there is a call for less capacity the following transition sequence is followed when staging down.

During each fixed speed compressor stage DOWN sequence, the VFD compressor speed is increased to maximum speed (which varies with unit size and number of operating fixed compressors) as a fixed speed compressor is turned off. Note that the VFD compressor speed range has been extended for these staging points to assure smooth transition and to minimize capacity gaps. Typically, the VFD compressor will be overdriven (higher speed than normal full load rating speed) when staging down a fixed compressor.

## Dehumidification Transition During Cooling State

When dehumidification operation becomes active while the unit is in the Cooling operating state, The VFD compressor is ramped to its maximum capacity. If the VFD capacity at this point is already above 75% of its full modulation a fixed compressor is also turned on. The compressors are held at this capacity for 1 minute before normal modulation resumes to maintain leaving coil temperature (LCT) resumes.

- VFD compressor will load up completely before starting any fixed speed compressors to achieve LCT of 45°F (default) with the VFD compressor option. LCT may be set between 45°F to 52°F.
- If reheat signal is at 100% for 10 minutes and the unit is unable to raise the DAT to desired point, the controller will stage off 1 fixed compressor and modulate the VFD compressor speed to achieve the DAT set point.

## Oil Boost Operational Sequence

When a low oil level is indicated in the VFD compressor sump, the unit switches to an oil boost state. The VFD compressor speed is increased during this mode to promote the return of refrigerant oil to the compressor.

To avoid short cycling of the oil boost sequence, no action is taken until a low oil indication has been present for 15 consecutive run minutes.

Upon entering oil boost sequence, the VFD compressor speed is increased to 70 rps. The VFD compressor runs at this condition until the optical oil sensor verifies that oil is present for 3 continuous minutes. Unit Controller default is set for a 10 minute max boost.

During the oil boost sequence the DAT temperature is overridden to allow the VFD compressor to continue operating until oil boost sequence termination.

If the VFD compressor is operating at or above 70 rps when an oil boost sequence is demanded, the VFD compressor is increased to the maximum allowable speed.

If one or more fixed speed compressors are operating in circuit #1 when the oil boost sequence is initiated, one fixed speed compressor will be turned off to minimize the disturbance to the DAT.

Oil boost sequences and durations are logged in the unit controller.

If the oil boost sequence runs for 15 continuous minutes (default setting) and cannot satisfy the oil optical sensor, the VFD compressor is operated for an additional 10 minutes at maximum allowable speed.

**NOTE:** See VFD Compressor Modulation Ranges Table on [page 99](#) for details.

If low indication does not clear, the VFD compressor will be shut down and oil level will be monitored for an additional 15 minutes. If low oil indication still does not clear within these 15 minutes, the VFD compressor will be locked out on alarm.

The low oil problem is also generated and the VFD compressor circuit is disabled if the oil boost sequence is initiated more than 4 times in a 24 hour period. If the oil boost sequence successfully restores the VFD compressor oil level the fixed compressor stage is returned to its pre-oil boost condition and normal compressor sequencing and modulation resumes.

## VFD Compressor Protection Unloading Control

There are several modulating control functions that adjust the speed control range of the VFD compressor to protect it from damage under abnormal operating conditions. The following functions are provided by the unit controller:

- High Pressure Unloading Control
- High Discharge Line Temperature Unloading Control
- High/Low Discharge Superheat Control
- Condenser Coil Splitter Valve Control

### High Pressure Unloading Control

The VFD compressor has an upper operating saturation discharge pressure limit of 575 PSIG. If the discharge pressure exceeds 575 PSIG, the compressor speed is reduced 1 rps every 10 seconds until the discharge pressure is at or below 575 psig. If the discharge pressure does not drop below 575 PSIG with the VFD compressor operating at minimum speed (30 rps), the compressor is locked out on alarm.

In addition, when the VFD compressor is operating above a saturation discharge pressure of 525 PSIG, the VFD compressor maximum speed is limited to 90 rps and the minimum speed is limited to 30 rps.

A high side pressure transducer is standard on both the VFD and fixed speed circuits allowing the discharge pressure of both refrigerant circuits to be viewed at the unit controller display.

If the unit controller needs to reduce the compressor speed in order to limit discharge pressure, the action is recorded in unit controller event log section.

**High Discharge Line Temperature Unloading Control**

A compressor discharge temperature sensor (Thermistor) is installed on the VFD compressor as standard. The temperature is used to measure discharge temperature and superheat levels at the VFD compressor discharge.

If the compressor discharge temp reaches 250°F, the VFD compressor speed is reduced by 10 rps and monitored for 3 additional minutes. The unit controller will continue to reduce VFD compressor speed by 10-rps increments until the discharge temp drops below 250°F. If the VFD compressor discharge temp reaches 250°F a warning will be logged in the controller. If reduced compressor speed does not resolve the issue, the VFD compressor is shut down and allowed to cool for 30 minutes. The VFD compressor is then re-started and if the discharge temperature cannot be held under 250°F, the VFD compressor is locked out. The root cause may be connected to a number of issues (low charge, blocked condenser coil, condenser fan failure, malfunctioning TEV, etc.) and service is needed.

The VFD compressor discharge Temp has an upper limit of 275°F. The VFD compressor will be shut down if discharge temp reaches 275°F.

**Low/High Discharge Superheat**

With the high side pressure transducer and discharge thermistor, the unit controller is capable of monitoring the variable speed compressor discharge superheat. This feature protects the VFD compressor against floodback, undercharged conditions, overcharged conditions, malfunctioning TEV, etc... Typical compressor superheat range is 20°F to 75°F. The discharge temperature of the VFD compressor can be viewed at the unit controller display.

**Low Superheat**

If the compressor discharge superheat falls below 20°F for 15 consecutive run minutes, the VFD compressor speed is increased by 5 rps increments up to a 60 rps operating speed. Superheat is monitored at each speed for 10 minutes and if superheat remains below 20°F, the VFD compressor speed is increased an additional 5 rps. When compressor discharge superheat level is at 20°F or above, the compressor speed is no longer increased. If speed correction resolves problem, the unit controller will have logged that a speed correction was needed for superheat in the event log. If increasing speed does not correct issue, the VFD compressor is locked out and an alarm is logged in the unit controller.

The fixed speed compressor(s) in circuit #1 do not contain this feature.

**High Superheat**

If the VFD compressor discharge superheat rises to 75°F for 10 consecutive minutes, the VFD compressor speed is reduced by 10 rps increments down to a 40 rps operating speed. Superheat is monitored at each speed for 10 minutes and if superheat remains above 75°F, the VFD compressor speed is decreased an additional 10 rps. When compressor discharge superheat level is at 75°F or below, the compressor speed is no longer decreased. If speed correction resolves problem, the unit controller will have logged that a speed correction was needed for superheat in the event log. If decreasing speed does not correct issue, the VFD compressor is locked out and an alarm is logged in the unit controller.

The fixed speed compressor(s) in circuit #1 do not contain this feature.

**Manual Control (with VFD Compressor)**

For service and troubleshooting the unit controller has capability to allow the VFD compressor to be operated manually. Refer to the controller OM for more detail.

The basic manual operations include the following:

- Start or Stop the VFD compressor
- Modulate VFD compressor from 0 – 100% speed
- Ability to energize condenser coil splitter solenoids
- Ability to initiate or terminate oil boost sequence

If an electrical issue with the VFD compressor is suspected, the winding resistance can be checked at the motor terminals.

**Table 21: VFD Compressor Winding Resistance**

Compressor Model	Voltage	Winding Resistance (Ohms)
VZH-088B-J	208-230V	0.03
VZH-117B-J		0.02
VZH-170B-J		0.01
VZH-088B-G	460V	0.1
VZH-117B-G		0.08
VZH-170B-G		0.05

### Condenser Coil Splitter Solenoid Valve Control

Condenser coil splitting is standard on both circuits of a VFD compressor unit. This feature assists in maintaining head pressure during low ambient/low modulating operation. A solenoid valve on each circuit is controlled by a digital output from the MicroTech controller.

The coil splitter solenoid valve is controlled based on the average discharge line pressure equivalent saturation temperature determined from the corresponding discharge pressure transducer, monitored via an analog input to the MicroTech controller.

The splitter solenoid valve on each circuit is normally open (digital output de-energized). The splitter valve on a circuit is closed (energized) when that circuit's saturation temperature remains below 83.0°F (250 psig) continuously for 60 seconds and the OAT is less than or equal to 80.0°F. The solenoid valve is re-opened when the saturation temperature rises above 105.0°F (350 psig) continuously for 60 seconds and the OAT rises above 80°F or when all the compressors on the circuit are OFF.

If the average saturated discharge temp falls below 250 PSIG (83°F) for 60 seconds and condenser coil splitter solenoid coil is energized (closed), the VFD compressor modulation rate is increased until an average saturated discharge temp of 250 PSIG (83°F) is achieved. This operation will raise the lower modulation limit of the VFD compressor, but is needed to keep the VFD compressor inside its operating envelope and maintain head pressure for TEV control.

When the condenser coil splitter is energized (closed) and the VFD compressor discharge pressure is below 250 PSIG, the VFD compressor speed is increased by 5rps increments every 30 seconds until the discharge pressure exceeds 250 PSIG. When the VFD compressor reaches 250 PSIG, this speed becomes the new minimum speed of the VFD compressor. As the discharge pressure rises above 250 PSIG, the minimum allowable compressor speed is decreased in 5 rps increments every 30 seconds.

If the condenser coil splitter valve is closed and the VFD compressor discharge remains below 250 PSIG for 15 minutes the circuit is locked out and an alarm is logged in the unit controller.

If a speed correction was performed to increase the compressor discharge pressure, there will be a record of the action in the unit controller under the event log.

### VFD Compressor Emergency Stop Control

If the VFD compressor enable output signal has been ON for 30 seconds and the controller fails to receive the VFD run verification input, *VFD Compressor Emergency Stop Control* is activated. When this function is active, VFD compressor enable output will be turned OFF for 5 seconds and then turned ON and ramp VFD compressor speed to 60Hz. If controller receives a VFD run verification input, a log event is set on *VFD Emergency Stop Control*. If controller fails to receive the VFD run verification input after 3 attempts in 30 minutes, the VFD compressor is locked out and the problem is logged.

Once active the *VFD Compressor Emergency Stop Control* function remains active until one of the conditions are met.

- VFD compressor enable output signal has been ON for 30 seconds and VFD compressor status Input is ON
- VFD compressor is OFF

If the controller fails to receive the VFD run verification input after the VFD compressor enable output signal has been ON for 30 seconds, the circuit is shut OFF on *VFD Compressor Emergency Stop Control* alarm.

Whenever this protection function becomes active a *VFD Compressor Emergency Stop Control* event is recorded in the Event Log with date and time stamp. Whenever this protection function returns to normal a *VFD Compressor Emergency Stop Control* return to normal event is recorded in the Event Log with date and time stamp.

## Variable Speed Scroll Compressor

**WARNING**

The compressor must only be used for its designed purpose(s) and within its scope of application (refer to the Operating Limits). Consult the Application Guidelines and datasheet available from [Danfoss.com](http://Danfoss.com). Under all circumstances, the EN378 (or other applicable local safety regulations) requirements must be fulfilled.

Daikin Applied units with variable speed inverter compressor are engineered with fixed speed compressor(s) in such a way that the unit delivers only the required energy to satisfy space conditions and provides you with exceptional energy savings. It improves comfort through precise temperature and humidity control. Variable speed compressor enhances energy efficiency and capable of providing unit capacity modulation down to 15% and reduces compressor cycling and wear on compressor.

Daikin Applied rooftop units with variable speed Inverter compressors are provided with Internal Permanent Magnet (IPM) motors. Compressors are designed to vary capacity by modulating the speed of the scroll set. The speed ratio for the IPM motor compressor is 4:1 (25 rps to 100 rps). Condenser fan modulation and an oil management/monitoring system are provided for reliable operation. The VFD compressor will always be on the "lead" circuit and will be the first one on and last one off.

Figure 120: Compressor Nameplate Information

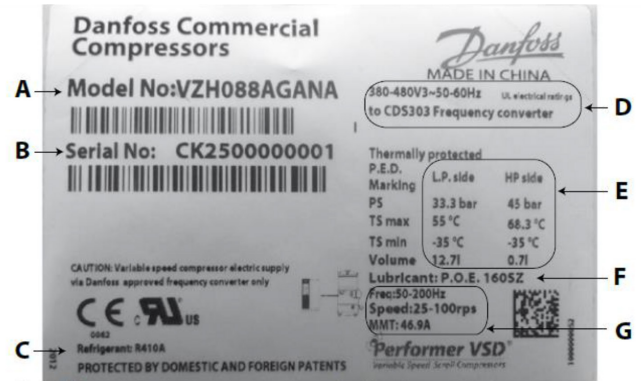

A.	Model number
B.	Serial number
C.	Refrigerant
D.	Supply voltage to CDS303 frequency converter
E.	Housing service pressure
F.	Factory charged lubrication
G.	Compressor frequency and MaxMust trip current

Figure 121: Compressor Components

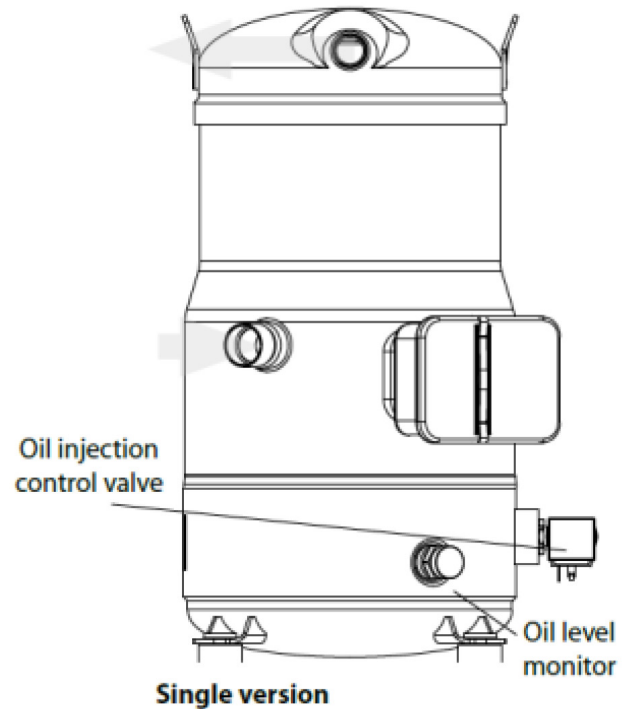



## Oil Injection Control

The VFD compressor contains an oil injection valve and solenoid (SV11) as standard. The oil injection valve provides lubrication to the scroll set under low speed/low refrigerant velocity situations. The oil injection valve is a normally closed valve. Below 50 rps (100 Hz) the valve is closed and directs oil to the scroll set suction port. Above 50 rps (100 Hz) the solenoid is bypassed and sends oil into sump. The oil injection valve/solenoid is mounted directly on the compressor and is controlled by the Compressor VFD (relay 1 output, terminals NO & Com). The coil voltage for the oil injection solenoid is 24 Vac.

The coil can be removed if required by carefully prying off the valve stem. The wiring connector is attached to the coil by a screw in the center of the housing. Refer to [Figure 122](#) and [Figure 123](#).

**Figure 122: Assembly Components**

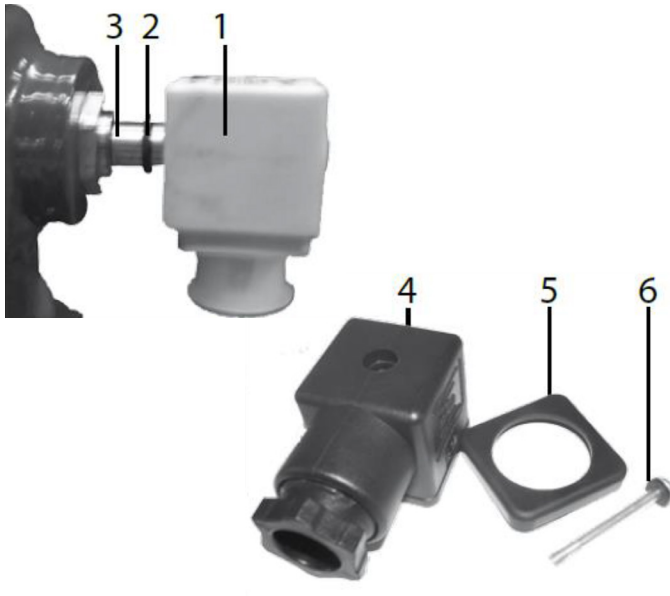

**Figure 123: Oil Injection Control Dismantling**

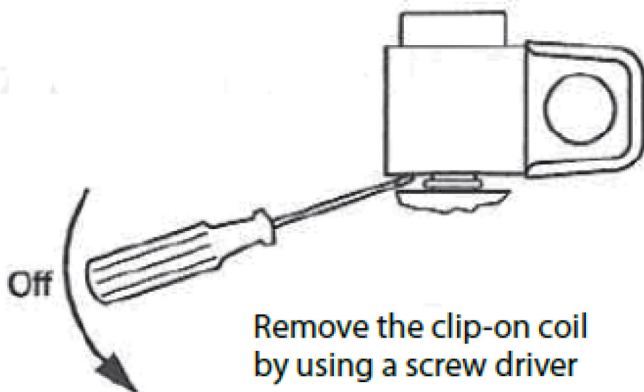

## Optical Oil Level Sensor

An optical oil sensor is used to monitor oil level in VFD compressor sump. The sensor is mounted directly to a fitting on the VFD compressor shell and can be removed without having to depressurize/reclaim the refrigeration system. Optical oil indication signal is sent to MicroTech Expansion Module 'C' (terminals X3 & M). Normal oil indication will provide a contact closure from relay R40. Relay R40 will de-energize during low oil indication, removing signal to terminal X3 and will start the unit in an oil boost sequence. Refer to [Figure 124](#) and [Figure 125](#)

**Figure 124: Sightglass for Optical Oil Sensor/Switch**



**Figure 125: Optical Oil Level Sensor/Switch**



## Electrical Connections and Wiring

### Basic Connections

Depending on the frequency converter version, the physical position of individual connectors may differ. Always make sure that the compressor terminals, U, V and W are connected to the frequency converter terminals, 96, 97 and 98 respectively.

The compressor motor cable is shielded and the armored part of the cable is connected to a ground on both cable ends; at the side of the compressor and at the side of the frequency converter.

## Variable Frequency Drive for VFD Compressor

**WARNING**

Never bypass the compressor drive or directly connect the VFD compressor to the main power supply.

The compressor drive used for this option is a special series (CDS 303) that is intended for use with an IPM compressor motor and cannot be replaced with any off the shelf VFD.

The compressor drive is mounted in a separate enclosure located in condensing section. Auxiliary ventilation is provided in the enclosure by fans M3 & M4 to protect the compressor drive from an over temp condition. The ventilation fans operate in conjunction with the compressor drive. Refer to Figure 18 for VFD panel layout.

The compressor drive and the LCP (local control panel) are preset with parameters from the factory and should not need to be changed in the field. The LCP is removable and is interchangeable with any of the compressor drives used by any of the VFD compressors. If the need arises to replace the compressor drive, the parameters can be downloaded from the LCP to the new compressor drive.

The compressor drive is preset to run the compressor clockwise and must be connected as shown in the unit schematic.

The compressor drive is preset for an open loop configuration with 0-10Vdc reference corresponding to 1500-6000 Rpm.

The compressor drive generates a soft start with an initial ramp of 2 seconds. In-rush current (or LRA) to the VFD compressor is typically not more than a few percent more than rated nominal Current.

Compressor Speed, modulation signal %, frequency signal, compressor amperage are all displayed in real time on the compressor drive screen. Alarms and descriptions will also be visible on the compressor drive screen.

### Basic Operation of Compressor Drive:

**Start=** Connect terminals 12 & 18 for minimum of 5 secs, connect terminals 12 & 27 and terminals 13 & 37

**Stop=** Disconnect terminals 12 & 27

**Emergency Stop=** Disconnect terminals 13 & 37

**Control/Modulation=** 0 to 10Vdc signal to terminals 53 & 55

**Run Verification=** A contact closure from relay 02 (terminals 04 & 05) is provided when drive is running

**Oil Injection=** A contact closure from relay 01 (terminals 01 & 02) is provided when compressor speed is greater than 50 rps (3000 rpm) which energizes the oil solenoid coil.

The compressor drive contains protection for the compressor against short circuits at the compressor terminals, overload protection, phase loss and earth faults. The compressor drive is protected against short-circuits.

**Table 22: Compressor Drive Model & Frame Size**

Compressor Model	Drive Model	Frame Size	
		208-230V	460V
VZH-088B	CDS303-15kW	B4	B3
VZH-117B	CDS303-18kW	C3	B4
VZH-170B	CDS303-22kW	C3	B4

Refer to the VFD operational manual for more information.

## Check, Test and Start Procedures

**⚠ WARNING**

Electric shock and moving machinery hazard. Can cause severe equipment damage, personal injury, or death.

Disconnect and tag out all electrical power before servicing this equipment.

All start-up and service work must be performed only by trained, experienced technicians familiar with the hazards of working on this type of equipment.

Read and follow this manual: "MicroTech Applied Rooftop Unit Controller" manual ([OM 920](#)) before operating or servicing.

Bond the equipment frame to the building electrical ground through grounding terminal or other approved means.

All units are completely run tested at the factory to promote proper operation in the field. Nevertheless, the following check, test, and start procedures must be performed to properly start the unit. To obtain full warranty coverage, complete and sign the check, test, and start form supplied with the unit, or complete the [Rooftop Equipment Warranty Registration Form on page 140](#) and return it to Daikin Applied.

A representative of the owner or the operator of the equipment should be present during start-up to receive instructions in the operation, care, and maintenance of the unit. If the unit has a factory mounted disconnect switch, use the switch's bypass mechanism to open the main control panel door without de-energizing the control panel. See [page 134](#) for instructions.

## Servicing Control Panel Components

**⚠ DANGER**

Hazardous voltage. May cause severe injury or death.

Disconnect electric power before servicing equipment. More than one disconnect may be required to de-energize the unit.

Disconnect all electric power to the unit when servicing control panel components. Unless power is disconnected to the unit, the components are energized. Always inspect units for multiple disconnects to ensure all power is removed from the control panel and its components before servicing.

### Before Start-up

1. Verify that the unit is completely and properly installed with ductwork connected.
2. Verify that all construction debris is removed, and that the filters are clean.
3. Verify that all electrical work is complete and properly terminated.
4. Verify that all electrical connections in the unit control panel and compressor terminal box are tight, and that the proper voltage is connected.

5. Verify all nameplate electrical data is compatible with the power supply.
  6. Verify the phase voltage imbalance is no greater than 3%.
  7. Verify that gas piping is complete and leak tight.
  8. Verify that the shutoff cock is installed ahead of the furnace, and that all air has been bled from the gas lines.
  9. Manually rotate all fans and verify that they rotate freely.
  10. Verify that the belts are tight and the sheaves are aligned.
  11. Verify that all setscrews and fasteners on the fan assemblies are still tight. Do this by reading and following the instructions in "Setscrews," which is in the "Maintenance" section of this manual.
  12. Verify that the evaporator condensate drain is trapped and that the drain pan is level.
  13. If unit is curb mounted, verify that the curb is properly flashed to prevent water leakage.
  14. Before attempting to operate the unit, review the control layout description to become familiar with the control locations.
  15. Review the equipment and service literature, the sequences of operation, and the wiring diagrams to become familiar with the functions and purposes of the controls and devices.
  16. Determine which optional controls are included with the unit.
  17. Before closing (connecting) the power disconnect switch, open (disconnect) the following unit control circuit switches:
    - a. Main Control Panel
      - Turn system switch S1 to OFF.
      - Electric heat units: turn switch HS1 to OFF.
    - b. Furnace Control Compartment
      - Turn furnace switch S3 to OFF.
      - Main Control Panel Switch S7 to OFF.
  18. If the DAC or SCC unit does not have an optional zone temperature sensor (ZNT1) connected to it, you may need to change the keypad entry under *Main Menu\Commission Unit\Unit Setup\Space Sensor = from none, Analog/Net, Digital/Net*.
- NOTE:** If desired, you can significantly reduce all MicroTech internal control timers by the changing the entry under keypad menu *Main Menu\Commission Unit\Timer Settings\Service Time = (from 0 min to X min where X is the number of minutes you want the unit to operate with fast timers)*.
19. Inspect the outside and inside of the unit for any signs of damage or rough handling. Excessive air leakage would be one possible, unacceptable consequence. If any problems are found, contact the local Daikin Applied representative for instructions.

**Power Up**

1. Close the unit disconnect switch. With the control system switch S1 in the OFF position, power should be available only to the control circuit transformer (T1) and the compressor crankcase heaters.
2. Turn the Switch S1 to ON. Power should now be supplied to the control panel, and the LEDs on MCB1 should follow the normal startup sequence (refer to [Power-up on page 54](#)).

**Fan Start-up**

1. Verify all duct isolation dampers are open. Unit mounted isolation dampers may be in the supply or return sections.
2. Place the unit into the Fan Only mode through the keypad menu *Main Menu\Quick Menu\Ctrl Mode = Fan*.
3. Turn Switch S7 to ON. The controller should enter the Startup Initial operating state. If the fan does not run:
  - a. Check fuses F1 and F3.
  - b. Check the manual motor protectors or that the circuit breakers have not tripped.
  - c. Check the optional phase monitor.
4. If the fans are equipped with optional spring isolators, check the fan spring mount adjustment. When the fans are running they should be level. Refer to [Spring Isolated Fans on page 51](#).
5. Verify the fan rotation is correct.
6. Verify the DHL safety is opening at a pressure compatible with duct working pressure limits.

**NOTE:** The supply and return fan drives usually are selected for operation in the drive's mid-speed range. The return fan drives are usually shipped with fixed pitch sheaves that will provide the selected fan speed; however, the supply fan drives are usually shipped with variable pitch sheaves that are adjusted to provide the minimum fan speed. Both drives should be adjusted for proper airflow during air balancing. See [Air Balancing on page 111](#).

**Economizer Start-up**

 **CAUTION**

Adjust dampers properly. Improper adjustment can damage the dampers. When an economizer is ordered without an actuator, the linkage requires a 3.14" linear stroke to open it fully. Do not allow dampers to be driven beyond their normal full closed or full open position.

1. Check whether the outdoor air is suitable for free cooling by displaying the keypad menu *Main Menu View\Set Unit\Econo Status*. See [OM 920 "Determining Economizer Status" section](#). *Low* indicates low outdoor air enthalpy; *High* indicates high outdoor air enthalpy. See [Enthalpy Control on page 78](#) to verify that the enthalpy changeover control is working properly. You may want to take temperature and humidity measurements.
2. At the keypad, set the cooling set point low enough so the controller calls for cooling. Adjust the value in *View\Set Unit\Cooling\Occ Clg Spt* below the temperature shown in *View\Set Unit\Temperatures\Control Temp*. In addition, on DAC units, adjust the value in *View\Set Unit\Cooling\DAT Clg Spt* below the temperature shown in *View\Set Unit\Temperatures\Discharge Temp*.
3. Place the unit into cooling mode through the keypad menu *Quick Menu\Ctrl Mode = Cool Only*.
4. Observe the outdoor air dampers:
  - a. If the outdoor enthalpy is low, the control algorithm should start to modulate the dampers open to maintain the discharge air set point.
  - b. If the outdoor enthalpy is high, the dampers should maintain their minimum position. Look at menu *View\Set Unit\Min OA Damper\Min OA Pos*. Change this entry to another value. Verify that the dampers move to the new minimum position set point.
5. If the unit is equipped with the electromechanical enthalpy changeover control (Honeywell H205) and the outdoor air condition is borderline, attempt to change its input to the MicroTech controller by turning the switch adjustment to A or D. Check enthalpy status in keypad menu *Main Menu View\Set Unit\Econo Status*. See [OM 920 "Determining Economizer Status" section](#). If this reading is *Low*, go to Step 5a. If it is *High*, go to Step 5b.

**NOTE:** It may not be possible to check the economizer operation in both low and high enthalpy states on the same day. If this is the case, repeat this procedure on another day when the opposite outdoor air enthalpy conditions exist.

## Compressor Startup

### CAUTION

Low ambient temperature hazard. Can cause compressor damage. Do not attempt to start up and check out the refrigeration system when the outdoor air temperature is below 50°F unless the unit is specially equipped for low ambient operation.

Inspect all refrigerant piping and look for leaks by looking for refrigerant oil residue. If any problem is found, reclaim any remaining refrigerant, fix the problem and then add the circuit's nameplate charge by weight before proceeding.

With the supply and return fans operational, prepare for compressor operation.

If the unit contains optional refrigeration service valves, they will be shipped closed. Open the discharge and suction valves. The valve are a quarter-turn ball valve type. Verify that the unit has not lost its refrigerant charge. Check the compressor oil level before startup. The oil level should be at or slightly above the center of the sight glass.

Verify that the crankcase heaters are operating. These should operate for at least 24 hours before starting the compressors.

**NOTE:** On VFD compressors VZH088 and VZH117, verify that the VFD is powered and providing a DC holding current to the compressor when the compressor is OFF. The holding current heats the compressor motor and is used in place of an external banded crankcase heater. The local control panel on the VFD will display that a holding current is present.

Verify that the condenser fan blades are positioned properly and that the screws are tight (see Figure 126). The fan blade must be correctly positioned within its orifice for proper airflow across the condenser coils.

Figure 126: Condenser Fan Blade Positioning

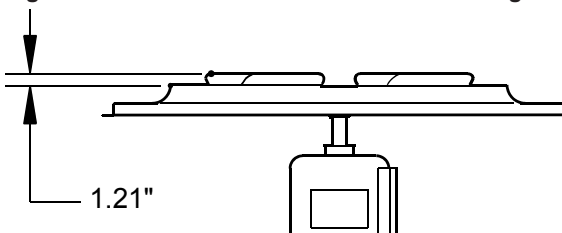

## Scroll Compressor Rotational Direction

Scroll compressors only compress in one rotational direction. Three-phase compressors can rotate in either direction depending upon phasing of the power to L1, L2, and L3. Since there is a 50/50 chance of connecting power to cause rotation in the reverse direction, verify that the compressor rotates in the proper direction after the system is installed. If the compressor is rotating properly, suction pressure drops and discharge pressure rises when the compressor is energized. If the compressor is rotating in reverse, the sound level is louder and current draw is reduced substantially. After several minutes of operation, the compressor's motor protector trips.

All three-phase compressors are wired the same internally. Therefore, once the correct phasing is determined for a specific system or installation, connecting properly phased power leads to the same terminals should maintain proper rotational direction.

On VFD compressors, if reverse rotation is noted at startup, the power leads (U and W) at the compressor should be reversed. Reversing the VFD's incoming power leads will not change the compressor's rotational direction.

Perform the following procedure on all units:

1. At the keypad, set the cooling set point low enough so that the controller will call for cooling. The value in *View\Set Unit\Cooling\Occ Clg Spt* will need to be adjusted below the temperature shown in *View\Set Unit\Temperatures\Control Temp*. In addition, on DAC units, the value in *View\Set Unit\Cooling\DAT Clg Spt* will need to be adjusted below the temperature shown in *View\Set Unit\Temperatures\Discharge Temp*.
2. Place the unit into cooling mode through the keypad menu *Quick Menu\Ctrl Mode = Cool Only*.
3. Verify that the low ambient compressor lockout temperature set point, *Main Menu\Commission Unit\Cooling Setup\Clg Lo OAT Lk* is set below the current outside air temperature (shown in *View\Set Unit\Temperatures\OA Temp*).

**NOTE:** Do not attempt to operate the compressors if the outdoor air is too cool. See the caution statement under "Compressor Startup".

4. Close the S1 switch. Now refrigeration circuit #1 is enabled and circuit #2 is disabled. After CS1 is closed, the MT III board starts its 5-minute timing cycle. Note that if the unit has an economizer and the outdoor air enthalpy is low, the economizer must fully open before the controller will energize mechanical cooling.
5. When the outdoor air damper has fully opened and the time delay has expired, the liquid line solenoid SV1 and the compressor should start.
  - a. Verify that there is a call for cooling by checking the keypad menu *Quick Menu\Unit State =*. This should be in *Cooling*.
  - b. Check the keypad menu *Main Menu\View\Set Unit\Unit Status\Settings\Clg Status =*. The compressors will only run if this reads (Enabled).
  - c. Trace the control circuits.

### NOTICE

Venting refrigerant to atmosphere is not allowed per most local laws and/or codes.

6. Verify that compressor #1 starts. If the compressor motor hums but does not run, verify that it is getting three-phase power.
7. The compressor should operate continuously while there is a call for cooling. If the compressor cycles on its low pressure switch, do the following:
  - a. Verify that the circuit is not short of refrigerant.
  - b. Check for low airflow.
  - c. Check for clogged filters.
  - d. Check for restricted ductwork.
  - e. Check for very low temperature return air entering the unit.
  - f. Verify that the liquid line components, expansion valve, and distributor tubes are feeding the evaporator coil.
  - g. Verify that all air handling section panels are closed.
  - h. Verify that the liquid line service valves are completely open.
8. Verify that the compressors stage properly. As the circuit loads up the second compressor (if available) will be energized. For more information on staging sequences, refer to [IM 919](#) and [OM 920](#).
9. Verify that the condenser fans are cycling and rotating properly (blowing air upward). When the compressor starts, at least one condenser fan should also start. The CCB1 should control the remaining condenser fans based on ambient air conditions. Look at keypad menu *Main Menu\Commission Unit\Cooling Setup\Cfan Out1 Spt =, Cfan Out2 Spt =, Cfan Out3 Spt*. [Table 3 on page 16](#) and [Table 4 on page 17](#) shows recommended set points based on the unit size. Cond Fan1 controls BO5, Cond Fan2 controls BO6, Cond Fan3 controls BO7, Cond Fan4 controls BO8. Refer to the unit wiring diagrams and [Table 5: Condenser Fan Arrangement on page 18](#).
10. After 15 minutes of run time, check the oil level in the compressor sightglass. If low oil or heavy foaming is observed, it is possible that liquid refrigerant is returning to the compressor. Check the suction superheat (see [Expansion Valve Superheat Adjustment](#)). It should be between 10°F (5.5°C) and 13°F (7.2°C).
11. Open S1. The compressor should stop. Place the unit into the "Fan Only" mode through the keypad menu *Main Menu\Quick Menu\Ctrl Mode = fan only*.
12. Check refrigerant circuit #2 by repeating steps 2 through 9, substituting circuit #2 nomenclature for circuit #1 nomenclature (CS2, TD2, CCB2, and compressor #2 (and #4)).
13. Check the compressor oil level again, add oil if low.
14. Verify that the condenser refrigerant subcooling at full capacity is between 13 and 20°F.

## Expansion Valve Superheat Adjustment

It is very important that the expansion valve superheat setting be adjusted to be between 8°F (-13°C) and 14°F (-10°C). Insufficient superheat will cause liquid floodback to the compressor which may result in slugging. Excessive superheat will reduce system capacity and shorten compressor life.

Turn the adjustment stem clockwise to increase superheat. Not exceeding one turn, adjust the stem and then observe the superheat. Allow up to 30 minutes for the system to rebalance at the final superheat setting.

On refrigeration circuits with multiple expansion valves, the superheat adjustment should be approximately the same for all valves in the circuit.

### Checking Superheat

Following are recommendations for checking superheat:

1. Close the unit section doors. Running the unit with its doors open will affect expansion valve and system operation considerably.
2. For units with one expansion valve per circuit, check the pressure and temperature at the compressor suction valve.
3. For units with multiple expansion valves per circuit, check the pressure at the compressor, and check the temperature at the suction header that is fed by the valve.

**NOTE:** If low oil level is accompanied by heavy foaming visible in the oil sightglass, it is possible that excess liquid refrigerant is returning to the compressor depending on the rotation of the crank shaft. Check the suction superheat and adjust the expansion valve for 8°F (-13°C) and 14°F (-10°C) of superheat. If proper superheat is obtained, sightglass foaming is not a concern.

For RCS/RFS applications in which the condensing section is remote from the air handling section, consideration should have been given to proper piping between the sections, as this can affect the compressor oil level. Refer to the ["ASHRAE Handbooks"](#) for more information on proper refrigeration piping design and installation.

## Heating System Startup

### General

1. At the keypad, set the heating set points high enough so that the controller calls for heating. Adjust the value in *Main Menu View\Set Unit\Heating\Occ Htg Spt* = (above the temperature shown in) *Main Menu View\Set Unit\Temperatures\Control Temp*. In addition, on DAC units, adjust the value in *Main Menu View\Set Unit\Heating\DAT Htg Spt* above the temperature shown in *Main Menu View\Set Unit\Temperatures\Disch Temp*.
2. Place the unit into heating mode through the keypad menu *Main Menu\quick Menu\Ctrl Mode = Heat Only*.
3. Verify that the high ambient heat lockout temperature set point, *Main Menu\Commission Unit\Heating Setup\Htg Hi OAT Lk* is set above the current outside air temperature (shown in *Main Menu\View\Set Unit\Temperatures\OATemp*).

### Gas Furnace

Refer to the “Start-up and Operating Procedures” section of the Forced Draft Gas Fired Furnace Installation Manual, [IM 684](#) or [IM 685](#). Perform the start-up procedures given in it.

### Electric Heat

Turn the electric heat switch HS1 to ON. The electric heaters should energize. If the unit has multistage electric heat, the MicroTech Auxiliary Control board EHB1 should energize the heaters in successive stages. The rate of staging is set in keypad menu *Main Menu\Commission Unit\Heating Setup\Htg Stage Time*. The default value of “5 min” can be adjusted from 2 to 60 minutes.

### Steam Heat

The steam valve actuator should open the valve. The steam valve is open when the valve stem is up. If the unit loses power, the spring in the actuator should drive the valve wide open. Check this by opening system switch S1.

### Hot Water Heat

The hot water valve actuator should open the valve to the coil. The three-way hot water valve is open to the coil when the valve stem is down. If the unit loses power, the spring in the actuator should drive the valve wide open to the coil. Check this by opening system switch S1.

## Air Balancing

### WARNING

Moving machinery hazard. Can cause severe personal injury or death.

Do not use a mechanically driven tachometer to measure the speed of return fans on this fan arrangement. Use a strobe tachometer.

### WARNING

Rotating parts can cause severe personal injury or death. Replace all belt/fan guards that are temporarily removed for service.

Air balancing should be performed by a qualified air balancing technician. Note that the supply fan motors are usually shipped with variable pitch sheaves which are typically set at the low end of the drive’s fan rpm range. See [Mounting and Adjusting Motor Sheaves on page 113](#). The return fan motors are usually shipped with fixed pitch sheaves.

The following should be performed as part of the air balancing procedure:

1. Check the operating balance with the economizer dampers positioned for both full outdoor air and minimum outdoor air.
2. Verify that the total airflow will never be less than that required for operation of the electric heaters or gas furnace.
3. For VAV units that have fan tracking control, adjust the supply/return fan balance by using the MicroTech controller’s built-in, automatic capability. For complete information on using this feature, see [OM 920](#), MicroTech Applied Rooftop Unit Controller.
4. When the final drive adjustments or changes are complete, check the current draw of the supply and return fan motors. The amperage must not exceed the service factor stamped on the motor nameplate.
5. Upon completion of the air balance, replace variable pitch motor sheaves (if any) with comparably sized fixed pitch sheaves. A fixed pitch sheave will reduce vibration and provide longer belt and bearing life.

## Drive Belt Alignments

### Sheave Alignment

#### Mounting:

1. Verify both driving and driven sheaves are in alignment and the shafts are parallel. The center line of the driving sheave must be in line with the center line of the driven sheave. See [Figure 127](#).
2. Verify that all setscrews are torqued to the values shown in [Table 30 on page 123](#) before starting drive. Check setscrew torque and belt tension after 24 hours of service.

**Figure 127: Sheave Alignment (Adjustable Shown)**

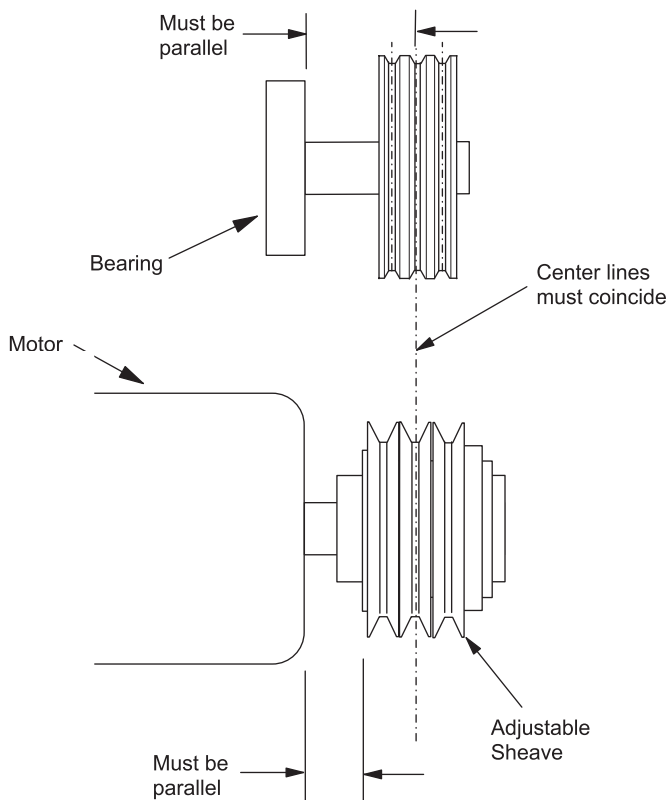

### Drive Belt Adjustment

#### General Rules of Tensioning

1. The ideal tension is the lowest tension at which the belt will not slip under peak load conditions.
2. Check tension frequently during the first 24 – 48 hours of operation.
3. Over tensioning shortens belt and bearing life.
4. Keep belts free from foreign material which may cause slippage.
5. Inspect V-belts on a periodic basis. Adjust tension if the belt is slipping. Do not apply belt dressing. This may damage the belt and cause early failure.

#### Tension Measurement Procedure

1. Measure the belt span. See [Figure 128](#).
2. Place belt tension checker squarely on one belt at the center of the belt span. Apply force to the checker, perpendicular to the belt span, until the belt deflection equals belt span distance divided by 64. Determine force applied while in this position.
3. Compare this force to the values on the drive kit label found on the fan housing.

**Figure 128: Drive Belt Adjustment**

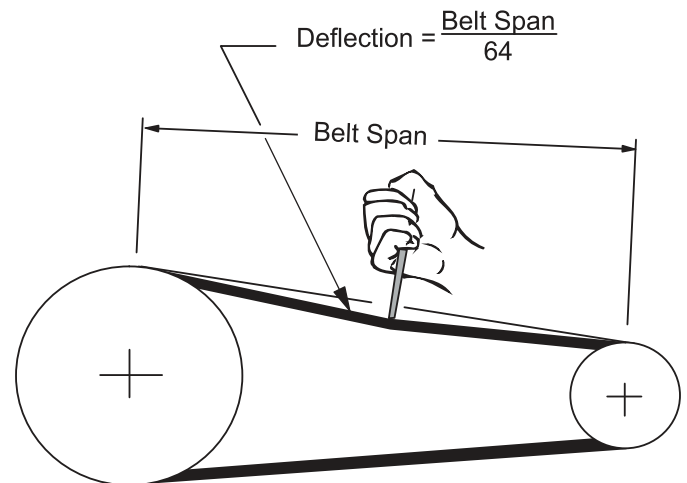



## Mounting and Adjusting Motor Sheaves

### VM and VP Variable Pitch Sheaves

#### Mounting:

1. Mount all sheaves on the motor shaft with setscrew A toward the motor (see [Figure 129](#)).
2. Be sure both the driving and driven sheaves are in alignment and that the shafts are parallel.
3. Fit internal key D between sheave and shaft and lock setscrew A securely in place.

#### Adjusting:

1. Slack off all belt tension by moving the motor toward the driven shaft until the belts are free from the grooves. For easiest adjustment, remove the belts.
2. Loosen setscrews B and C in the moving parts of the sheave and pull out external key E (see [Figure 129](#)). This key projects a small amount to provide a grip for removing.
3. Adjust the sheave pitch diameter for the desired fan speed by opening the moving parts by half or full turns from closed position. Do not open more than five full turns for A belts or six full turns for B belts. Adjust both halves of two-groove sheaves by the same number of turns from closed to ensure both grooves have the same pitch diameter.
4. Replace external key E and securely tighten setscrews B over the key. Tighten setscrews C into the keyway in the fixed half of the sheave.
5. Put on belts and adjust the belt tension. Do not force belts over grooves. Loosen the belts by adjusting the motor base closer to the fan shaft.
6. Be sure that all keys are in place and that all setscrews are tight before starting the drive. Check the setscrews and belt tension after 24 hours of service.

**Figure 129: VM and VP Variable Pitch Sheaves**

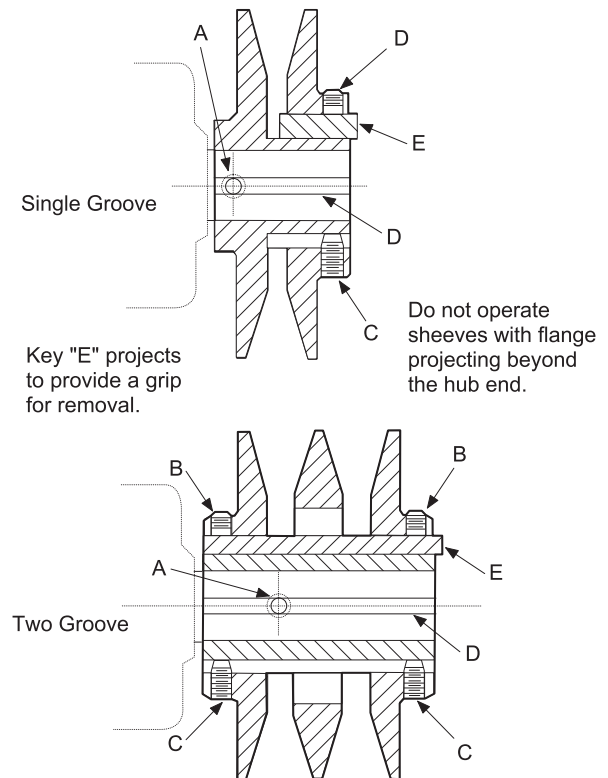

**LVP Variable Pitch Sheaves**

**Mounting:**

1. For single-groove sheaves, slide the sheave onto the motor shaft so that the side of the sheave with setscrew A is next to the motor (see Figure 130). For two-groove sheaves, slide the sheave onto the motor shaft so that the side of the sheave with setscrew A is away from the motor.
2. To remove the flange and locking rings:
  - a. Loosen setscrews D.
  - b. Loosen but do not remove capscrews E.
  - c. Remove key F. This key projects a small amount to provide a grip for removing.
  - d. Rotate the flange counterclockwise until it disengages the threads on the shaft barrel.
3. Be sure that the driving and driven sheaves are in alignment and the shafts are parallel. When aligning two-groove sheaves, allow room between the sheave and motor to get to capscrews E.
4. Insert key C between the sheave and the shaft and tighten setscrew A securely.

**Adjusting:**

1. Slack off all belt tension by moving the motor toward the driven shaft until the belts are free from the grooves. For easiest adjustment, remove the belts.
2. Loosen setscrews D.
3. Loosen but do not remove capscrews E.
4. Remove key F. This key projects a small amount to provide a grip for removing.
5. Adjust the pitch diameter by opening or closing the movable flange by half or full turns. Note that two-groove sheaves are supplied with both grooves set at the same pitch diameter. To ensure the same pitch diameter for satisfactory operation, move both movable flanges the same number of turns. Do not open sheaves more than five turns for A belts or six turns for B belts.
6. Replace key F.
7. Tighten setscrews D and capscrews E.
8. Put on the belts and adjust the belt tension. Do not force belts over grooves. Loosen the belts by adjusting the motor base closer to the fan shaft
9. Before starting the drive, make sure that all keys are in place and all setscrews and all capscrews are tight. Check and retighten all screws and retention the belts after approximately 24 hours of operation.

**Figure 130: LVP Variable Pitch Sleeves**

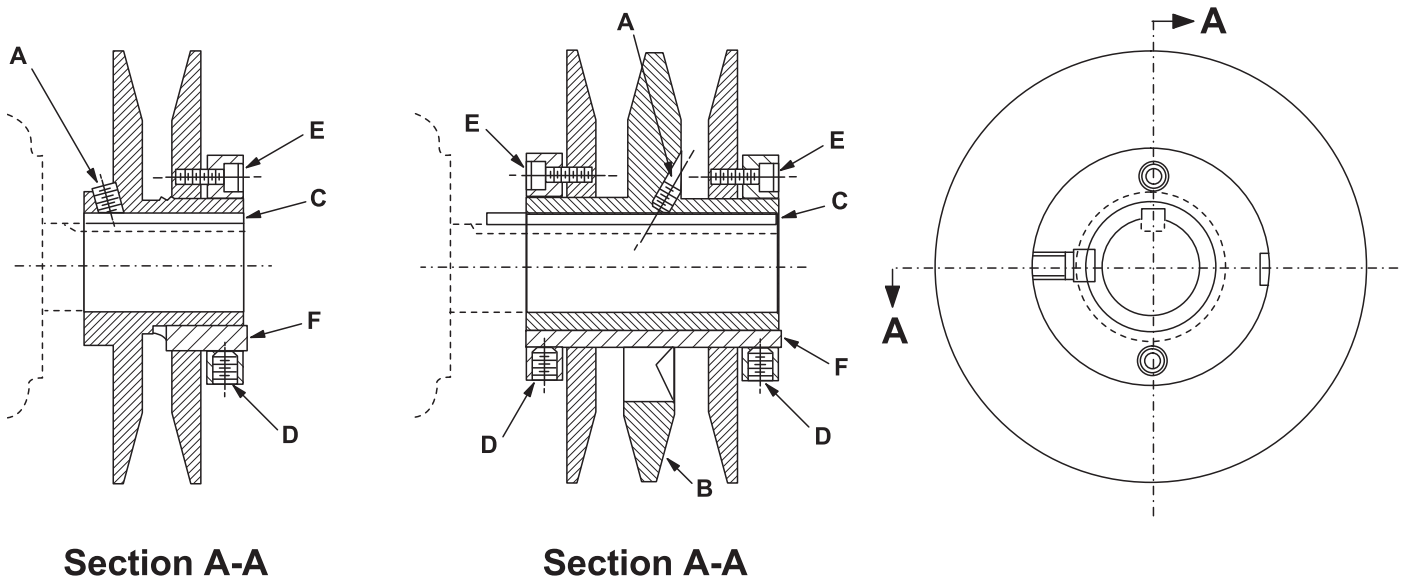

**MVP Variable Pitch Sheaves**

**Adjusting:**

1. Slack off belt tension by moving the motor toward the driven shaft until the belts are free from the grooves. For easiest adjustment, remove the belts.
2. Loosen both locking screws A in outer locking ring, but do not remove them from the sheave. There is a gap of approximately 1/2" (1 mm) between the inner and outer locking rings. This gap must be maintained for satisfactory locking of the sheave.

If locking screws A are removed by accident and the gap is lost, screw the outer locking ring down until it touches the inner locking ring. Then back off the outer ring 1/2 to 3/4 turn until the inner and outer ring screw holes line up. Reinsert locking screws A, but do not tighten them until after adjustment is made.

3. Adjust the sheave to the desired pitch diameter by turning the outer locking ring with a spanner wrench. Any pitch diameter can be obtained within the sheave range. One complete turn of the outer locking ring will result in a 0.233" (6 mm) change in pitch diameter. Do not open A-B sheaves more than four 3/4 turns for A belts or 6 turns for B belts. Do not open C sheaves more than nine 1/2 turns.
4. Tighten both locking screws A in the outer locking ring.
5. Put on the belts and adjust the belt tension. Do not force belts over grooves. Loosen the belts by adjusting the motor base closer to the fan shaft.

**⚠ CAUTION**

Do not loosen any screws other than the two locking screws (A) in the outer locking ring. Before operating the drive, securely tighten these screws.

**Figure 131: MVP Variable Pitch Sheaves (Type A-B)**

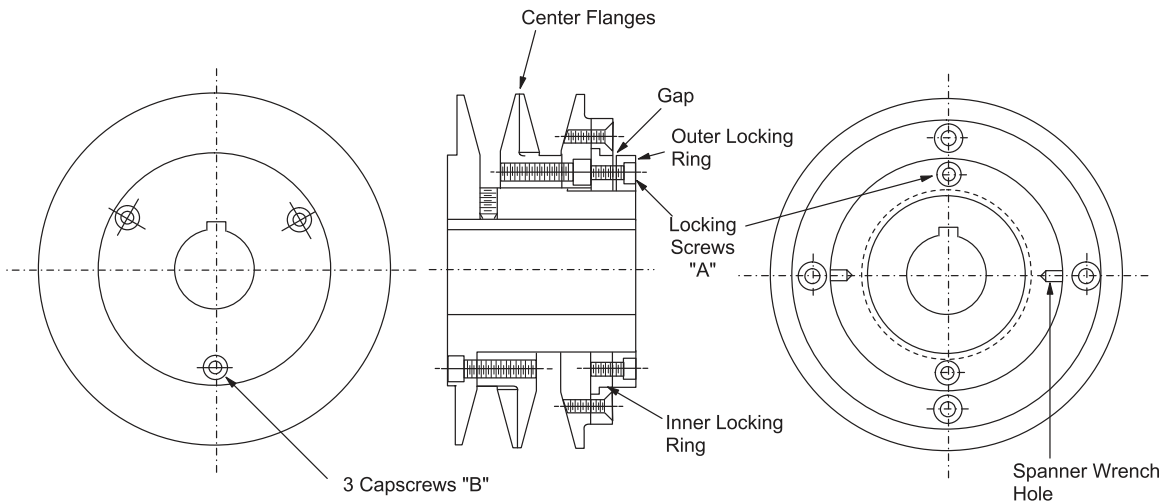

**Figure 132: MVP Variable Pitch Sheaves (Type A-B)**

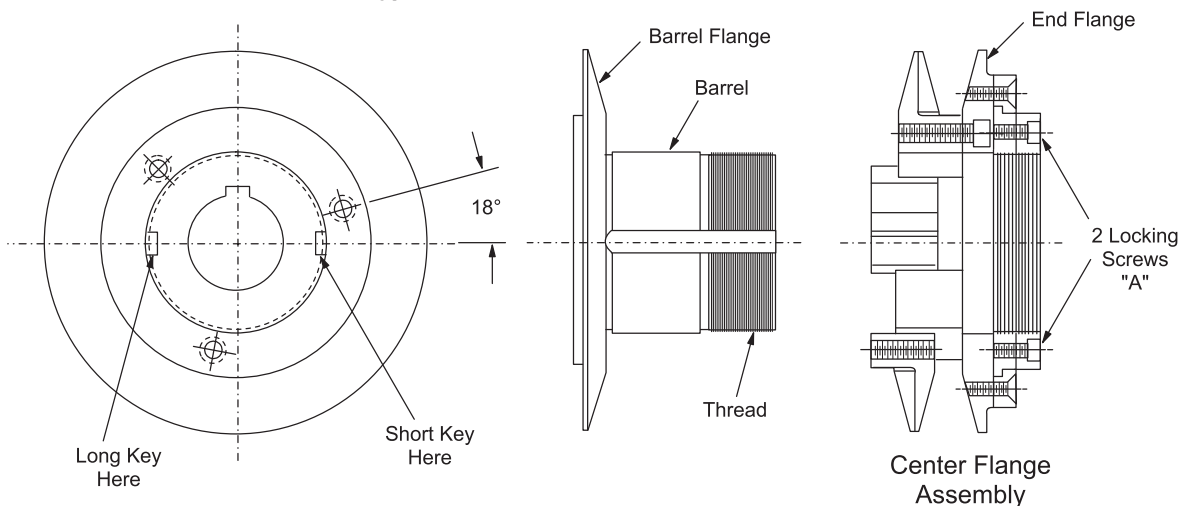

When all start-up procedures are completed, set the controls and program the MicroTech controller for normal operation. Use the following list as a guide; some items may not apply to your unit. For more detail, see [IM 919](#) and [OM 920](#).

1. Turn system switch S1 to ON and S7 to AUTO.
2. Turn gas furnace switch S3 to AUTO or turn electric heat switch HS1 to ON.
3. Set the electromechanical (Honeywell H205) enthalpy control (OAE) as required (A, B, C, or D). Set the solid-state (Honeywell H705/C7400) enthalpy control (OAE/RAE) past D.
4. Set the heating and cooling parameters as required for normal unit operation.
  - a. *Main Menu\View\Set Unit\Cooling\Occ Clg Spt & DAT Clg Spt.*
  - b. *Main Menu\View\Set Unit\Heating\Occ Htg Spt & DAT Htg Spt.*
5. Set the low ambient compressor lockout set point as required in menu, *Main Menu\Commission Unit\Cooling Setup\Clg Lo Oat Lk =*. Do not set it below 50°F (10°C) unless the unit is equipped for low ambient operation.
6. Set the high ambient heat lockout temperature set point, *Main Menu\Commission Unit\Heating Setup\Htg Hi OAT Lk* as required.
7. Set the alarm limits as required in *Main Menu\Commission Unit\Alarm Configurations\Alarm Limits*.
8. Set the compressor lead/lag function as desired using keypad menu *Main Menu\Commission Unit\Cooling Setup\Lead Circuit* and *Main Menu\Commission Unit\Cooling Setup\Staging Type*. Refer to “Compressor Staging” in [IM 919](#) and [OM 920](#).
9. Set the duct static pressure control parameters as required in keypad menu *Airflow\Duct Pressure*.
10. Set the building static pressure control parameters as required in keypad menu
  - a. *Main Menu\View\Set Unit\RF/EF Control\Bldg SP Spt.*
  - b. If RF/EF Control = Tracking, then set the fan tracking parameters as required in keypad menu. *Main Menu\Commission Unit\RF/EF Setup\Sup Fan Max, RF @ SF Max, Sup Fan Min, RF @ SF Min.*
11. Set the economizer control parameters as required in keypad menu *Main Menu\View\Set Unit\Economizer\OAD/Econo Pos*.
12. Set the control timers as required in keypad menu *Main Menu\Commission Unit\Timer Settings*.
  - a. Set the date and time in keypad menu *Setup\Service\Time/Date*.
  - b. Set the operating schedule as required using keypad menus. *Main Menu\View\Set Unit\Date\Time\Schedules*.

**NOTE:** Note: When used with a Building Automation System, these settings may need to be kept at the default of no schedule.

### Maintaining Control Parameter Records

Daikin Applied recommends that the MicroTech controller’s set points and parameters be recorded and saved for future reference. If the Microprocessor Control Board requires replacement, this record facilitates entering the unit’s proper data. The following tables display all the set points, monitoring points, and program variables offered by MicroTech plus the keypad road map used to find each parameter.

A number of menus and menu items that appear on the unit keypad/display are conditional and may not apply to a specific unit, depending on the unit software configuration. The unit software configuration is defined by a “Software Configuration Code” shown on a label located near the keypad/display. The Software Configuration Code also can be displayed via the six menu items in the Config Code menu on the unit keypad/display. Refer to [OM 920](#).

**NOTE:** Keep a record of any changes made to any of these items.

 <b>CAUTION</b>
If the unit has hot gas bypass on circuit #1 only, lead circuit must always be #1.

## Using the Keypad/Display

The keypad/display consists of a 5-line by 22 character display, three keys and a “push and roll” navigation wheel. There is an Alarm Button, Menu (Home) Button, and a Back Button. The wheel is used to navigate between lines on a screen (page) and to increase and decrease changeable values when editing. Pushing the wheel acts as an Enter Button.

The first line on each page includes the page title and the line number to which the cursor is currently “pointing”. The line numbers are X/Y to indicate line number X of a total of Y lines for that page. The left most position of the title line includes an “up” arrow to indicate there are pages “above” the currently displayed items, a “down” arrow to indicate there are pages “below” the currently displayed items or an “up/down” arrow to indicate there are pages “above and below” the currently displayed page.

Each line on a page can contain status only information or include changeable data fields. When a line contains status only information and the cursor is on that line all but the value field of that line is highlighted meaning the text is white with a black box around it. When the line contains a changeable value and the cursor is at that line, the entire line is highlighted. Each line on a page may also be defined as a “jump” line, meaning pushing the navigation wheel will cause a “jump” to a new page. An arrow is displayed to the far right of the line to indicate it is a “jump” line and the entire line is highlighted when the cursor is on that line.

The keypad/display Information is organized into five main menus or menu groups; Alarm Lists Menu, System Summary Menu, Standard Menus, Extended Menus and Advance Menus.

**NOTE:** Only menus and items that are applicable to the specific unit configuration are displayed.

The Alarm Lists Menu includes active alarm and alarm log information. The System Summary Menu includes status information indicating the current operating condition of the unit. Standard Menus include basic menus and items required to setup the unit for general operation. These include such things as control mode, occupancy mode and heating and cooling set points. Extended Menus include more advanced items for “tuning” unit operation such as PI loop parameters and time delays. Advanced Menus include the most advanced items such as “unit configuration” parameters and service related parameters. These generally do not need changing or accessing unless there is a fundamental change to or a problem with the unit operation.

Figure 133: Keypad Controls

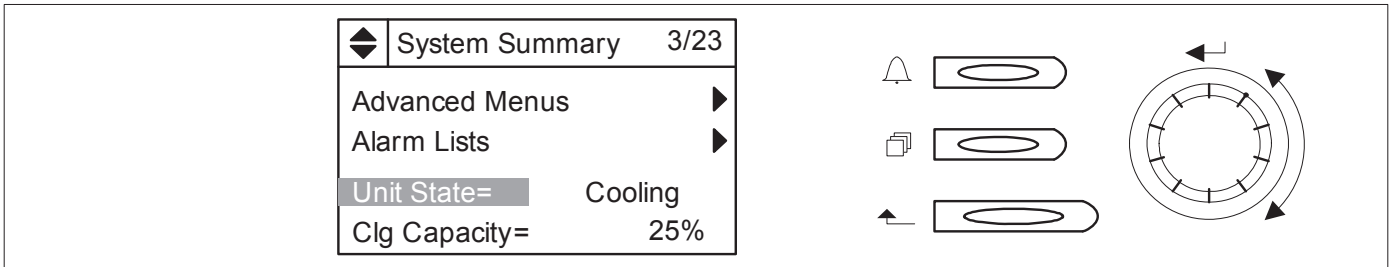

## Passwords

When the keypad/display is first accessed, the Home Key is pressed, the Back Key is pressed multiple times, or if the keypad/display has been idle for the Password Timeout timer (default 10 minutes), the display will show a "main" page where the user can enter a password or continue without entering a password.

The three password levels available are Level 2, Level 4, and Level 6, with Level 2 having the highest level of access. Entering the Level 6 password allows access to the Alarm Lists Menu, System Summary Menu, and the Standard Menus group. Entering the Level 4 password allows similar access to Level 6 with the addition of the Extended Menus group. Entering the Level 2 password allows similar access to Level 4 with the addition of the Advanced Menus group. The Level 2 password is 6363, the Level 4 is 2526, and the Level 6 password is 5321.

Continuing without entering one of these three levels allows access only to the Alarm Lists Menu and the System Summary Menu.

**NOTE:** Alarms can be acknowledged without entering a password.

The password field initially has a value \*\*\*\* where each \* represents an adjustable field. These values can be changed by entering the Edit Mode.

Entering an invalid password has the same effect as continuing without entering a password.

Once a valid password has been entered, the controller allows further changes and access without requiring the user to enter a password until either the password timer expires or a different password is entered. The default value for this password timer is 10 minutes. It is changeable from 3 to 30 minutes via the Timer Settings menu in the Extended Menus.

**Figure 134: Password Main Page**

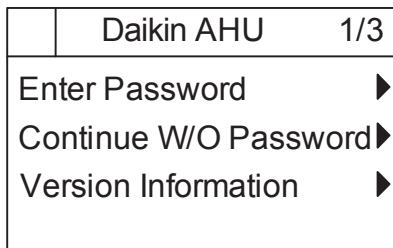

**Figure 135: Password Entry Page**

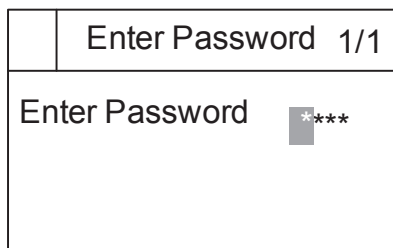

## Navigation Mode

In the Navigation Mode, when a line on a page contains no editable fields all but the value field of that line is highlighted meaning the text is white with a black box around it. When the line contains an editable value field the entire line is inverted when the cursor is pointing to that line.

When the navigation wheel is turned clockwise, the cursor moves to the next line (down) on the page. When the wheel is turned counter-clockwise the cursor moves to the previous line (up) on the page. The faster the wheel is turned the faster the cursor moves.

When the Back Button is pressed the display reverts back to the previously displayed page. If the Back button is repeated pressed the display continues to revert one page back along the current navigation path until the "main menu" is reached.

When the Menu (Home) Button is pressed the display reverts to the "main page."

When the Alarm Button is depressed, the Alarm Lists menu is displayed.

## Edit Mode

The Editing Mode is entered by pressing the navigation wheel while the cursor is pointing to a line containing an editable field. Once in the edit mode pressing the wheel again causes the editable field to be highlighted. Turning the wheel clockwise while the editable field is highlighted causes the value to be increased. Turning the wheel counter-clockwise while the editable field is highlighted causes the value to be decreased.

The faster the wheel is turned the faster the value is increased or decreased. Pressing the wheel again cause the new value to be saved and the keypad/display to leave the edit mode and return to the navigation mode.

## Keypad/Display Menu Structure

Refer to the unit controller Operation Manual (OM) for details on menu items and configurations.

**NOTE:** Menu items displayed will change based on selected unit configuration.

**⚠ WARNING**

Installation and maintenance must be performed only by qualified personnel who are experienced with this type of equipment and familiar with local codes and regulations.

**⚠ WARNING**

Moving machinery and electrical power hazards. May cause severe personal injury or death.  
Disconnect and lock off all power before servicing equipment.

**⚠ CAUTION**

Sharp edges are inherent to sheet metal parts, screws, clips, and similar items. May cause personal injury. Exercise caution when servicing equipment.

## Servicing Control Panel Components

**⚠ DANGER**

Hazardous voltage. May cause severe injury or death. Disconnect electric power before servicing equipment. More than one disconnect may be required to de-energize the unit.

Disconnect all electric power to the unit when servicing control panel components. Before servicing, always inspect units for multiple disconnects to ensure all power is removed from the control panel and its components.

## Planned Maintenance

Preventive maintenance is the best way to avoid unnecessary expense and inconvenience. Have this system inspected at regular intervals by a qualified service technician. The required frequency of inspections depends upon the total operating time and the indoor and outdoor environmental conditions. Routine maintenance should cover the following items:

- Tighten all belts, wire connections, and setscrews.
- Clean the evaporator and condenser coils mechanically or with cold water, if necessary. Usually any fouling is only matted on the entering air face of the coil and can be removed by brushing.
- Lubricate the motor and fan shaft bearings.
- Align or replace the belts as needed.
- Clean or replace the filters as needed.
- Check each circuit's refrigerant sightglass when the circuit is operating under steady-state, full load conditions. The sightglass should then be full and clear. If it is not, check for refrigerant leaks.

**NOTE:** A partially full sight glass is not uncommon at part load conditions.

- Check for proper superheat.
- Check for proper subcooling.
- Check for blockage of the condensate drain. Clean the condensate pan as needed.
- Check the power and control voltages.
- Check the running amperage of all motors.
- Check all operating temperatures and pressures.
- Check and adjust all temperature and pressure controls as needed.
- Check and adjust all damper linkages as needed.
- Check the operation of all safety controls.
- Examine the gas furnace (see [IM 684](#) or [IM 685](#)).
- Check the condenser fans and tighten their setscrews.
- Lubricate the door latch mechanisms.

## Unit Storage

### Location

The Daikin Applied Rooftop Packaged System Unit is an outdoor unit. However, the schedule may dictate storage either on the ground or in its final position at the site. If the unit is stored on the ground, additional precautions should be taken as follows:

- Make sure that the unit is well supported along the length of the base rail.
- Make sure that the unit is level (no twists or uneven ground surface).
- Provide proper drainage around the unit to prevent flooding of the equipment.
- Provide adequate protection from vandalism, mechanical contact, etc. The condenser fins are particularly vulnerable to damage by even light contact with ground based objects.
- Make sure all doors are securely closed.
- If isolation dampers are provided, verify that they are properly installed and fully closed to prevent the entry of animals and debris through the supply and return air openings.
- Units without isolation dampers should be fitted with covers over the supply and return air openings.

### Preparation

#### Supply (and Return) Fans

1. Move the motor base to check and lubricate slides and leadscrews.
2. Remove the drive belts, tag them with the fan name and unit serial number, and store them in a conditioned space out of direct sunlight.
3. Turn the supply and return fan manual motor protectors (MMP) to the OFF position.
4. Once every two weeks, rotate the fan and motor shafts. Mark the shaft positions first to make sure they stop in a different position.
5. Depending on local climatic conditions, condensate may collect on components inside the units. To prevent surface rust and discoloration, spray all bare metal parts with a rust preventive compound. Pay close attention to fan shafts, sheaves, bearings, and bearing supports.

#### Cabinet Sections

Once a month, open a door on each section and verify that no moisture or debris is accumulating in the unit.

#### Cooling Circuits

The steps below are necessary only if the unit has been started.

1. Turn the compressor manual motor protectors (MMP) to the OFF position.
2. Close the discharge and liquid line refrigerant service valves on each circuit.
3. Tag the valves as a warning for the technician who restarts the units.

#### Gas Furnace

If the unit is equipped with a gas furnace, close the gas shutoff valve and open furnace control switch S3.

#### Control Compartment

1. Daikin Applied recommends that the electronic control equipment in the unit be stored in a 5% to 95% RH (non-condensing) environment.
2. It may be necessary to put a heat source (light bulb) in the main control panel to prevent the accumulation of atmospheric condensate within the panel.
3. The location and wattage of the heat source is dependent on local environmental conditions.
4. Check the control compartment every two weeks to check that the heat source is functional and is adequate for current conditions.

#### Restart

After extended storage, perform a complete start up. Inevitable accumulations of dirt, insect nests, etc. can contribute to problems if not cleaned out thoroughly prior to start up. In addition, thermal cycling tends to loosen mechanical and electrical connections. Following the startup procedure helps discover these and other issues that may have developed during the storage interval.

#### Gas Furnace

For information on maintenance of the gas furnace, refer to [IM 684](#) or [IM 685](#).



## Bearing Lubrication

**CAUTION**

Bearing overheating potential. Can damage the equipment. Do not over lubricate bearings. Use only a high grade mineral grease with a 200°F safe operating temperature. See below for specific recommended lubricants.

### Motor Bearings

Supply and return fans—Supply and return fan motors should have grease added after every 2000 hours of operation. Using the following procedure, re-lubricate the bearings while the motor is warm, but not running. Use one of the greases shown in Table 23.

1. Remove and clean upper and lower grease plugs.
2. Insert a grease fitting into the upper hole and add clean grease (Table 23) with a low pressure gun.
3. Run the motor for five minutes before replacing the plugs.

**NOTE:** Specific greasing instructions are located on a tag attached to the motor. If special lubrication instructions are on the motor, they supersede all other instructions.

**Condenser fan**—Condenser fan motors are permanently lubricated and require no periodic lubrication.

**Table 23: Recommended Lubricants and Amounts for Fan Motor Bearings**

Mfr. Grease	NEMA Size	Amount to Add (oz.)
Texaco, Polystar or Polyrex EM (Exxon Mobile) or Rykon Premium #2 or Penzoil Pen 2 Lube	56 to 140	0.08
	140	0.15
	180	0.19
	210	0.30
	250	0.47
	280	0.61
	320	0.76
	360	0.81
	400	1.25
	440	2.12

### Fan Shaft Bearings

**CAUTION**

For safety, stop rotating equipment. Add one half of the recommended amount shown in Table 26 on page 122. Start bearing, and run for a few minutes. Stop bearing and add the second half of the recommended amount. A temperature rise, sometimes 30°F (1°C), after re-lubrication is normal. Bearing should operate at temperature less than 200°F (94°C) and should not exceed 225°F (107°C) for intermittent operation. For a re-lubrication schedule, see Table 24. For any applications that are not in the ranges of the table, contact Daikin Applied.

**CAUTION**

The following tables state general lubrication recommendations based on our experience and are intended as suggested or starting points only. For best results, specific applications should be monitored regularly and lubrication intervals and amounts adjusted accordingly.

Any good quality lithium or lithium complex base grease, using mineral oil, conforming to NLGI grade 2 consistency, and an oil viscosity of 455-1135 SUS at 100°F (100-200 cSt at 40°C) may be used for re-lubrication.

Compatibility of grease is critical. Re-lubricatable Browning bearings are supplied with grease fittings or zerks for ease of lubrication with hand or automatic grease guns. Always wipe the fitting and grease nozzle clean.

**Table 24: Re-lubrication Intervals\***

Speed	Temperature	Cleanliness	Relub. intervals
100 rpm	Up to 120°F (50°C)	Clean	6 to 12 months
500 rpm	Up to 150°F (65°C)	Clean	2 to 6 months
1000 rpm	Up to 210°F (100°C)	Clean	2 weeks to 2 months
1500 rpm	Over 210°F (100°C) to 250°F (120°C)	Clean	Weekly
Above 1500 rpm	Up to 150°F (65°C)	Dirty/wet	1 week to 1 month
Max catalog rating	Over 150°F (65°C) to 250°F (120°C)	Dirty/wet	Daily to 2 weeks
	Above 250°F (120°C)		Contact Browning

\*Use NLGI #2 Lithium or Lithium Complex Grease)

**Table 25: Recommended Lubricants for Fan Shaft Ball Bearings**

Name	Temperature	Base	Thickener	NLGI grade
Texaco, Premium RB	30° to 350°F (34° to 177°C)	Parafinic mineral oil	Lithium	2
Mobile, AW2	40° to 437°F (40° to 175°C)	Mineral oil	Lithium	2
Mobile, SHC 100	68° to 356°F (50° to 180°C)	Synthetic	Lithium	2
Chevron, Altplex Synthetic	60° to 450°F (51° to 232°C)	Synthetic	Lithium	2
Exxon, ronex MP	40° to 300°F (40° to 149°C)	Mineral oil	Lithium	2

**Note:** Temperature ranges over 225°F are shown for lubricants only. High temperature applications are not suitable for standard air handler components.

**Table 26: Recommended Fan Re-lubrication Grease Charge**

Shaft Size (in)	Oz.	Shaft Size	Grams
1/2 to 3/4	0.03	20 mm	0.85
7/8 to 1-3/16	0.10	25-30 mm	2.84
1-1/4 to 1-1/2	0.15	35-40 mm	4.25
1-11/16 to 1-15/16	0.20	45-50 mm	5.67
2 to 2-7/16	0.30	55-60 mm	8.51
2-1/2 to 2-15/16	0.50	65-70 mm	15.59
3 to 3-7/16	0.85	75-80 mm	24.10
3-1/2 to 4	1.50	85-105 mm	42.53

**Bearing Replacement**

The following instructions must be read in entirety before attempting installation or removal.

<b>CAUTION</b>
The procedures indicated should be carefully followed. Failure to do so can result in improper installation which could cause bearing performance problems as well as serious personal injury.

**Bearings in Bolt-On Housings (Units)**

- 1 Check area - Clean and organize bearing installation area and keep well lit. Be sure mounting surfaces are clean and flat.
- 2 Check shaft - Shaft should be within tolerance range shown in [Table 27](#), clean, and free of nicks and burrs. Mount bearing on unused section of shafting or repair/replace shafting as required.
- 3 Install unit - Slide unit onto shaft. If it is difficult to mount bearing on shaft, use a piece of emery cloth to reduce any high spots on shaft. Do not hammer on any component of the bearing.
- 4 Fasten unit in place - Install housing mounting bolts, check and align bearing and tighten mounting bolts to recommended fastener torques. Exercising extreme caution and safety, rotate shaft slowly to center bearing.

**Table 27: Shaft Size Tolerances**

Shaft Size (in)	Tolerance
1-11/16 to 2-7/16	+0 to -0.0015
2-7/16 and up	+0 to -0.002

**BOA Concentric Inserts**

1. Be sure that BOA Concentric collar is fitted square and snug against the shoulder on the inner ring.
2. Torque BOA Concentric collar cap screw to torque recommended in [Table 28](#).

**Table 28: Recommended Torque Values for Concentric Locking Bearing/Shaft Size**

Fan Size (in)	Bore Size (in)	Torx Screw	
		Size	In lbs.
27 (AF)/40 & 49 (SWSI)	2-3/16	T-30	180
30 & 33 (AF)/44 (SWSI)	2-7/16	T-45	400
36 (AF)	2-11/16	T-45	400
40 (AF)	2-15/16	T-45	400

**Note:** AF = DWDI AF, SWSI = AF Plenum Fan

### Monitor Installed Bearing

After bearing has been run for several minutes, and again after several hours, check bearing for excessive noise or vibration. Shutdown machine and check housing temperature: typical applications operate at 100°F - 105°F (38°C - 66°C). Tighten all locking devices after 500 hours or 3 months, whichever comes first.

### Propeller Exhaust Fan

See [Propeller Exhaust Fan Option on page 92](#).

### Vibration Levels

Each unit as shipped is trim balanced to operate smoothly. To provide satisfactory operation after shipping and installation, use accepted industry guidelines for field balancing fans. See [Table 29](#).

**NOTE:** Excessive vibration from any cause contributes to premature fan and motor bearing failure. Monitor overall vibration levels every six months of operation. An increase in levels is an indication of potential trouble.

**Table 29: Vibration Levels**

Fan speed (RPM)	Vibration
800 or less	5 mils maximum displacement
801 or greater	0.20 in/sec maximum velocity

### Vibration Causes

1. Wheel imbalance.
  - a. Dirt or debris on wheel blades.
  - b. Loose setscrews in wheel hub.
  - c. Wheel distorted from overspeed.
2. Bent shaft.
3. Faulty drive.
  - a. Variable pitch sheaves—Axial and radial runout of flanges; uneven groove spacing; out of balance. Also similar faults in driven sheave.
  - b. Bad V-belts; lumpy, or mismatched; belt tension too tight or too loose.
4. Bad bearings, loose bearing hold-down bolts.
5. Motor imbalance.
6. Fan section not supported evenly on foundation.

### Periodic Service and Maintenance

1. Check all moving parts for wear every six months.
2. Check bearing collar, sheave, and wheel hub setscrews, sheave capscrews, and bearing hold-down bolts for tightness every six months.

### Setscrews

Setscrews are used to lock sheaves, locking collars, and fan wheels to their shafts. They must be checked periodically to see that they have not loosened. If this is not done, severe equipment damage could occur.

Using [Table 30](#), check the tightness of all setscrews with a torque wrench. Note that if the return fan bearings setscrews must be retightened, a special procedure is required to equally load both bearings (see "Return Fan Bearing Setscrews").

**Table 30: Setscrew Minimum Torque Specifications**

Setscrew diameter (in.)	Minimum torque (ft.lb)
1/4	5.5
5/16	10.5
3/8	19.0
7/16	29.0
1/2	42.0
5/8	92.0

### Return Fan Bearing Setscrews

 **IMPORTANT**

To maintain proper drive alignment and fan-to-tunnel clearance, the fan and shaft must not drop at all when the setscrews are loosened in Step 4.

Because the return fan is mounted on a vertical shaft, the following procedure must be used to retighten any return fan bearing setscrews that have loosened. This procedure will provide that both bearings are equally loaded. If one bearing is carrying the entire weight of the fan, it could fail prematurely.

1. Loosen the fan belts.
2. Support the weight of the fan and the fan shaft with timbers or some other suitable means (see the fan shaft support in [Figure 136](#)).
3. Verify that the upper shaft collar is securely fastened to the shaft. Check the setscrew torque.
4. Loosen the upper and lower bearing setscrews. The entire weight of the fan and shaft is now supported by the fan shaft support.
5. Retighten all bearings to the torque specification given in [Table 28](#). Remove the fan shaft support and retention the belts.

**Figure 136: Return Fan Assembly**

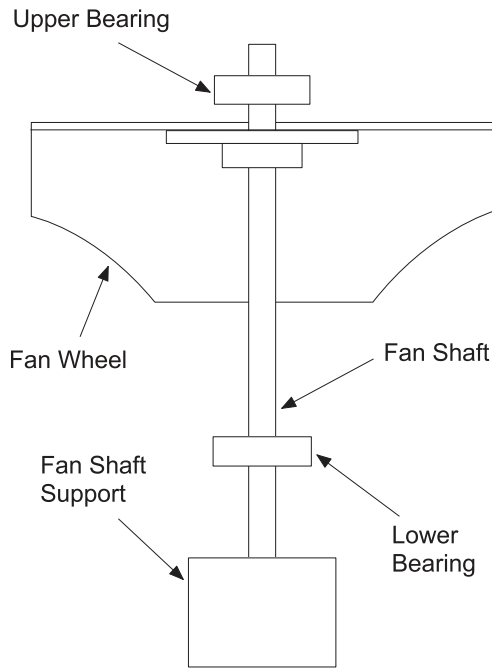

**Figure 137: 20" DWDI Airfoil Wheel-to-Funnel**

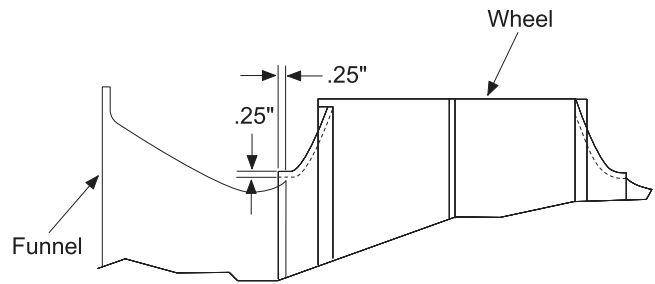

**Figure 138: 24" DWDI Backward Curved Wheel-to-Funnel**

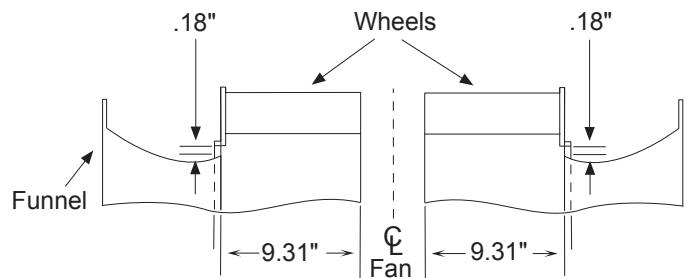

**Supply Fan Wheel-to-Funnel Alignment**

If the unit is equipped with an airfoil or backward curved supply fan, the fan wheel-to-funnel alignment must be as shown in [Figure 137](#), [Figure 138](#), [Figure 139](#), [Figure 140](#) and [Figure 141](#) to obtain proper air delivery and operating clearance. If necessary, adjustments are made as follows:

1. Verify that the fan shaft has not moved in its bearings.
2. Loosen the fan hub setscrews and move the wheel(s) along the shaft as necessary to obtain the correct dimension shown in [Table 31](#), [Table 32](#), and [Table 33](#).
3. Retighten the setscrews to the torque specification given in [Table 30](#) on page 123. Tighten the setscrews over the keyway first; tighten those at 90 degrees to the keyway last.
4. Verify that the radial clearance around the fan is uniform. Radial clearance can be adjusted by slightly loosening the funnel hold-down fasteners, shifting the funnel as required, and retightening the fasteners.

**Figure 139: 27" to 40" DWDI Airfoil Wheel-to-Funnel**

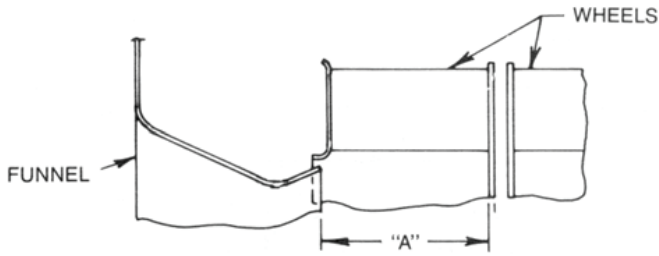

**Table 31: 27" to 40" DWDI Airfoil Wheel-to-Funnel Relationship**

Wheel-to-funnel relationship (in inches)	
Wheel diameter (inches)	A +0.3/ - 0.0
27	9.9 (246 mm)
30	10.6 (269 mm)
33	11.7 (297 mm)
36	13.1 (333 mm)
40	14.5 (368 mm)

**Figure 140: 44" and 49" SWSI Airfoil Wheel-to-Funnel**

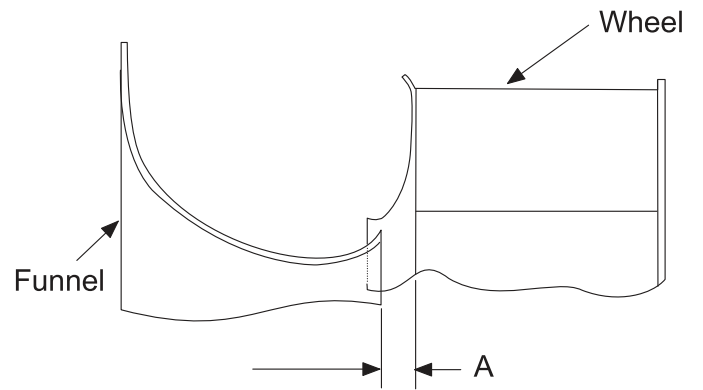

**Table 32: 44" and 49" SWSI Airfoil Wheel-to-Funnel Relationship**

Wheel-to-funnel relationship (in inches)	Wheel diameter "A"
44	16.21
49	17.81

**Figure 141: 40" SWSI Airfoil Wheel-to-Funnel Alignment**

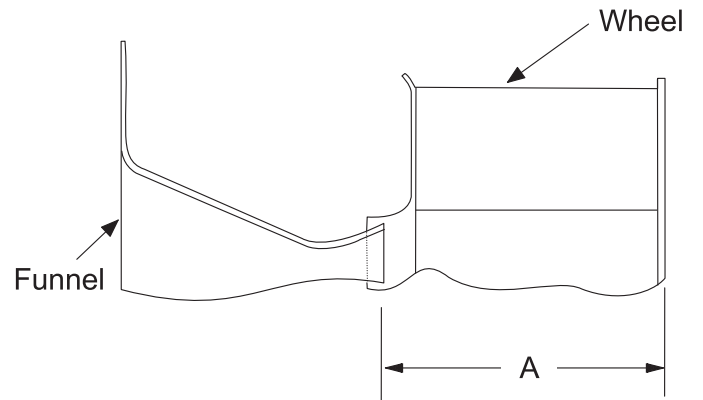

**Table 33: SWSI airfoil wheel-to-funnel relationship**

Wheel-to-funnel relationship (in inches)	Wheel diameter A
40	0.62

# Scroll Compressor Piping

**CAUTION**

The compressor must be handled with caution in the vertical position with a maximum offset from vertical of 15°. The compressor is delivered under a nitrogen gas pressure (between 0.3 and 0.7 bars) and cannot be connected as is; refer to the assembly section for further details.

When replacing an individual scroll compressor on tandem or trio assemblies, three refrigerant lines must be disconnected and re-assembled:

1. TPTL Oil Equalization Line
  - a. This line (Figure 142) contains the oil sight glass.
  - b. This line connects to each compressor at “rota-lock” fittings (Figure 143).
  - c. This line should be disconnected and re-used.
2. Suction Line
  - a. This is the largest diameter piping.
  - b. This line is brazed to each compressor.
3. Discharge Line
  - a. This is the tubing that connects near the top of the compressor.
  - b. This line is brazed to each compressor.

Figure 142: Oil Equalization Line

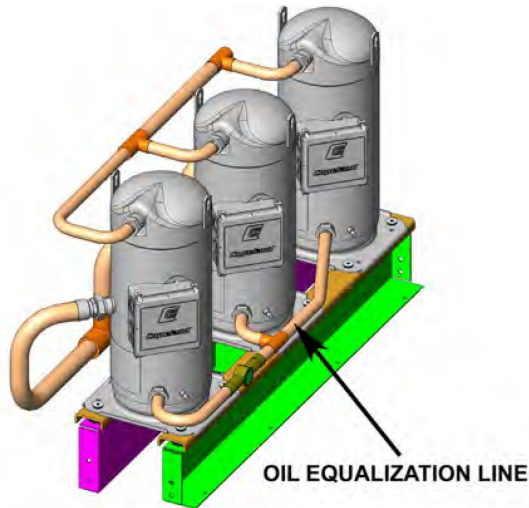

Figure 143: Oil Equalization Line with Rota-Lock Fittings

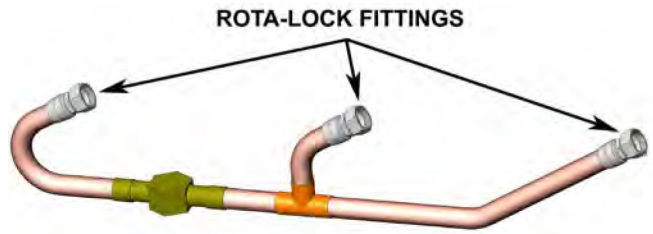

Figure 144: Suction Tubes

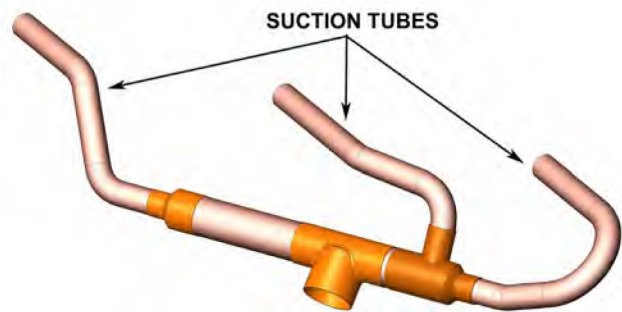
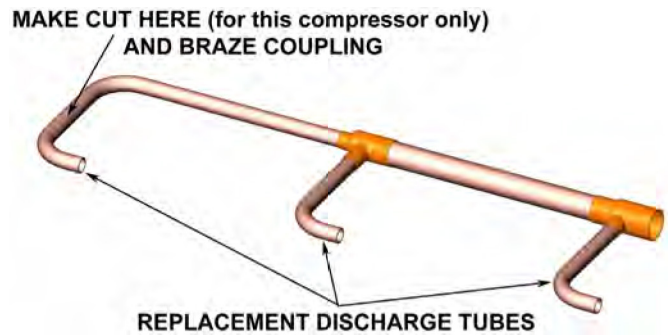

Figure 145: Discharge Tubes



**Preferred Replacement**

1. Drain the oil.
2. Disconnect the TPTL line.
3. Cut out the failed compressor at the suction and discharge tubes.  
 Make the cuts in the straight portions of the replacement tubes and as near the compressor as possible.
4. Braze couplings on the cut end of the original tubes so that they fit snugly into place.
5. Replace the TPTL oil equalization line.
6. Cut the new suction and discharge tubes to fit between the compressor and the couplings.
7. Assemble the new tubes but do not braze until everything fits snugly.
8. Braze tubes into place.

**Alternative Replacement**

1. Drain the oil.
2. Disconnect the TPTL line.
3. Cut out the failed compressor at the suction and discharge tubes.
4. Remove the compressor.
5. Un-sweat the cut suction and discharge stubs from their fittings and completely clean the old braze joint.
6. Place the new compressor into position.
7. Replace the TPTL oil equalization line.
8. Place the entire replacement discharge and suction tubes into position so that the tubes fit snugly into place.
9. Braze the tubes into place.

**Figure 146: Micro-Channel Coil Cross-Section**

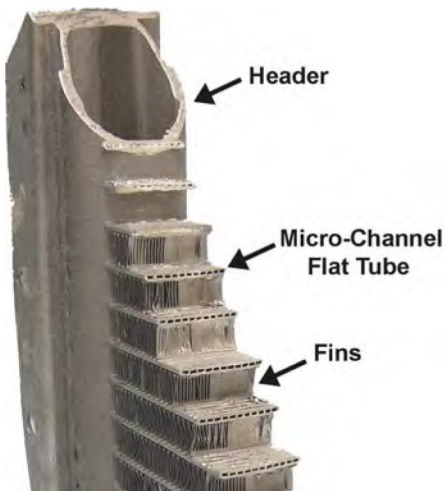

**All-Aluminum Condenser Coils**

The condenser coils are an all-aluminum design including the connections, micro-channels, fins (an oven brazing process brazes the fins to the micro-channel flat tube), and headers (Figure 146), which eliminates the possibility of corrosion normally found between dissimilar metals of standard coils.

During the condensing process, refrigerant in the coil passes through the micro-channel flat tubes, resulting in higher efficiency heat transfer from the refrigerant to the airstream.

In the unlikely occurrence of a coil leak, contact Daikin Applied to receive a replacement coil module.

**Connecting the Condenser Coil to Copper Tubing**

**⚠ CAUTION**

Potential equipment damage. If a standard copper brazing process is performed at this joint, the process will damage the aluminum connection. If a coil needs replacing, contact Daikin Applied for a coil and copper connection assembly.

Figure 147 and Figure 148 show the aluminum condenser coil connection(s) to the copper tubing in the unit. Because of the low melting point of aluminum (1220°F compared to 1984°F for copper), this brazed joint is performed with a low temperature brazing process.

**Figure 147: Aluminum/Copper Connections**

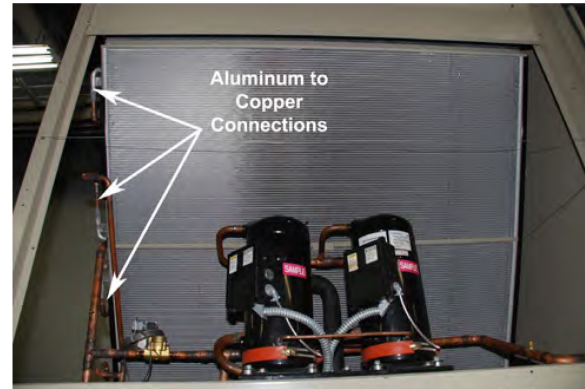

**Figure 148: Connection Close-Up**



## Refrigerant Charge

### WARNING

Potential severe loss of charge may occur if the high refrigerant pressure switch is replaced before reclaiming the refrigerant. Replace switch after reclaiming refrigerant.

The unit nameplate references proper charge for each RPS/RDT refrigerant circuit in case a full charge must be added to the unit. Verify these values using [Table 11 on page 33](#). Refer to [Table 11 on page 33](#) for RFS/RCS units.

The micro-channel condenser requires much less charge than traditional fin tube condensers. This means there is 35% less charge to recover when servicing the refrigeration circuit, but the condenser will not hold a high percentage of the charge. The impact on service is as follows:

- Positive impact - the replacement refrigerant portion of service cost will be less.
- Positive impact - it takes less time to reclaim the entire charge or the high side portion of the system.
- Negative impact - it takes more time to reclaim the low side portion of the system because you cannot first pumpdown most to the high side.

The micro-channel condenser coil design does not contain the internal volume to support the pumpdown of the entire unit charge into the condenser coil. To aid in the removal of refrigerant from the system, a Schrader valve port with a core has been provided on the liquid line, ahead of the liquid line shut-off valve. The port is intended for connecting to a suitable (and approved) storage container while using the unit compressor(s) to pump liquid refrigerant into a storage container.

The compressors can be isolated for servicing if the unit has been ordered with the optional discharge and suction ball valves. These service ball valves, 1/4" Schrader port—standard option, aid with recovering, evacuating and charging when servicing a compressor.

## Cleaning Option E Coated Coils

### WARNING

Prior to cleaning the unit, turn off and lock out the main power switch to the unit and open all access panels.

The following cleaning procedures are recommended as part of the routine maintenance activities for Option E Coated Coils. Documented routine cleaning of Option E Coated Coils is required to maintain warranty coverage.

### **Remove Surface Loaded Fibers**

Surface loaded fibers or dirt should be removed prior to water rinse to prevent further restriction of airflow. If unable to back wash the side of the coil opposite that of the coils entering air side, then surface loaded fibers or dirt should be removed with a vacuum cleaner. If a vacuum cleaner is not available, a soft non-metallic bristle brush may be used. In either case, the tool should be applied in the direction of the fins. Coil surfaces can be easily damaged (fin edges bent over) if the tool is applied across the fins.

**NOTE:** Use of a water stream, such as a garden hose, against a surface loaded coil will drive the fibers and dirt into the coil. This will make cleaning efforts more difficult. Surface loaded fibers must be completely removed prior to using low velocity clean water rinse.

### **Periodic Clean Water Rinse**

A monthly clean water rinse is recommended for coils that are applied in coastal or industrial environments to help to remove chlorides, dirt and debris. An elevated water temperature (not to exceed 130°F) will reduce surface tension, increasing the ability to remove chlorides and dirt. Pressure washer PSI must not exceed 900 psig and the nozzle should remain at least 1 foot from the coil to avoid damaging fin edges.

### **Routine Quarterly Cleaning of Option E Coated Coil Surfaces**

Quarterly cleaning is essential to extend the life of an Option E Coated Coil and is required to maintain warranty coverage. Coil cleaning shall be part of the unit's regularly scheduled maintenance procedures. Failure to clean an Option E Coated Coil will void the warranty and may result in reduced efficiency and durability in the environment.

For routine quarterly cleaning, first clean the coil with the below approved coil cleaner (see approved products list under [Recommended Coil Cleaner](#) section). After cleaning the coils with the approved cleaning agent, use the approved chloride remover ([Table 34](#)) to remove soluble salts and revitalize the unit.



**Recommended Coil Cleaner**

**⚠ CAUTION**

Harsh Chemical and Acid Cleaners

Harsh chemicals, household bleach or acid cleaners should not be used to clean outdoor or indoor Option E Coated Coils. These cleaners can be very difficult to rinse out of the coil and can accelerate corrosion and attack the Option E coating. If there is dirt below the surface of the coil, use the recommended coil cleaners as described above.

High Velocity Water or Compressed Air

High velocity water from a pressure washer or compressed air should only be used at a very low pressure to prevent fin and/or coil damages. The force of the water or air jet may bend the fin edges and increase air side pressure drop. Reduced unit performance or nuisance unit shutdowns may occur.

The following cleaning agent, assuming it is used in accordance with the manufacturer’s directions on the container for proper mixing and cleaning, has been approved for use on Option E Coated Coils to remove mold, mildew, dust, soot, greasy residue, lint and other particulate:

**Table 34: Option E Coated Coil Recommended Cleaning Agents**

Cleaning Agent	Reseller	Part No.
Enviro-Coil Concentrate	<a href="#">Hydro-Balance Corp</a> P.O. Box 730 Prosper, TX 75078 800-527-5166	H-EC01
Enviro-Coil Concentrate	<a href="#">Home Depot</a>	H-EC01
Chloride Remover	<a href="#">Chlor*Rid Int'l, Inc.</a> P.O. Box 908 Chandler AZ 85244 800-422-3217	Chlor*Rid DTS

CHLOR\*RID DTS™ should be used to remove soluble salts from the Option E Coated Coil, but the directions must be followed closely. This product is not intended for use as a degreaser. Any grease or oil film should first be removed with the approved cleaning agent.

1. Remove Barrier - Soluble salts adhere themselves to the substrate. For the effective use of this product, the product must be able to come in contact with the salts. These salts may be beneath any soils, grease or dirt; therefore, these barriers must be removed prior to application of this product. As in all surface preparation, the best work yields the best results.
2. Apply CHLOR\*RID DTS - Apply CHLOR\*RID DTS directly onto the substrate. Sufficient product must be applied uniformly across the substrate to thoroughly wet out surface, with no areas missed. This may be accomplished by use of a pump-up sprayer or conventional spray gun. The method does not matter, as long as the entire area to be cleaned is wetted. After the substrate has been thoroughly wetted, the salts will be soluble and is now only necessary to rinse them off.
3. Rinse - It is highly recommended that a hose be used, as a pressure washer will damage the fins. The water to be used for the rinse is recommended to be of potable quality, though a lesser quality of water may be used if a small amount of CHLOR\*RID DTS is added. Check with CHLOR\*RID International, Inc. for recommendations on lesser quality rinse water.

## Servicing Refrigerant Sensors or Switches

### WARNING

#### Variable Speed Inverter Compressor

The VFD is factory-programmed and should not be modified in the field. Any modifications will void the warranty. Compressors are compatible with the manufacturer's VFD only.

The Daikin Applied Rooftop unit includes the following refrigerant sensors or switches.

1. Low refrigerant pressure sensing, operating switch, automatic reset.
  - a. Disables their associated compressors on a drop in suction pressure. Units with Fantrol, set point = 70 psig. Units with Speedtrol, set point = 50 psig (low ambient).
  - b. Enables their associated compressors on a rise in suction pressure. Units with Fantrol, set point = 120 psig. Units with Speedtrol, set point = 90 psig.
2. High refrigerant pressure, protective switch, manual reset, reset by breaking control power to the S1 control switch.
  - a. All R-410A high pressure switches disable their associated compressors on a rise in discharge pressure to 650 psig.
  - b. The switches have a differential of 150 psig.

The low pressure and SpeedTrol sensors/switches sense refrigerant pressure through Shrader fittings that contain cores. The cores are stop valves that do not allow refrigerant to flow through the Shrader unless the device is in place. Therefore the low pressure and SpeedTrol sensors/switches can be replaced without reclaiming the refrigerant.

The Shrader that serves the high pressure switch does not contain a core in order to maximize the functionality of the safety. Therefore it cannot be replaced unless the refrigerant has already been reclaimed.

## Winterizing Water Coils

Coil freeze-up can be caused by such things as air stratification and failure of the outdoor dampers and/or preheat coils. Routine draining of water cooling coils for winter shutdown cannot be depended upon as insurance against freeze-up. Severe coil damage may result. It is recommended that all coils be drained as thoroughly as possible and then treated in the following manner.

- Fill each coil independently with an antifreeze solution using a small circulating pump and again thoroughly drain.
- Check freezing point of antifreeze before proceeding to next coil. Due to a small amount of water always remaining in each coil, there will be a diluting effect. The small amount of antifreeze solution remaining in the coil must always be concentrated enough to prevent freeze-up.

**NOTE:** Carefully read instructions for mixing antifreeze solution used. Some products have a higher freezing point in their natural state than when mixed with water.

## Control Panel Components

The following motor control protection is provided.

**Table 35: RoofPak Individual Motor Control and Protection**

Motor Type	Short Circuit	Overload	On-Off
Compressor < 100 Amps	MMP	Internal	Contactors
Compressor > 100 Amps	CB	Internal	Contactors
Condenser Fans	MMP	VFD	Contactors
EAF, One Fan	CB*	OL	Contactors
EAF, 2-3 Fans	CB*		Contactors
SAF & RAF with VFD No Bypass In Bypass	CB* CB	VFD OL	Contactors Contactors

MMP = manual motor protector  
 Internal = vendor motor protect  
 CB = circuit breaker [\* FB with MD4  
 OL = over load relay

### Manual Motor Protector (MMP)

The manual motor protector (MMP) provides coordinated branch circuit, short circuit protection, a disconnecting means, a motor controller, and coordinated motor overload protection. A short circuit indicator with manual reset is mounted alongside of each MMP as a means to differentiate between a short circuit and overload trip conditions.

The MMP trip points are factory set. Do not change unless the motor ampacity changes or the MMP is replaced with a new device with incorrect set point adjustment. Any other non-authorized trip point or set point adjustment voids all or portions of the unit's warranty. Authorized set point adjustments accomplished as follows:

1. For motors with a 1.15 service factor, rotate the arrow on the dial to correspond to the motor FLA.
2. For motors with a 1.0 service factor, multiply the motor FLA by 0.9; then rotate the arrow on the dial to correspond to that value.

To reset a tripped MMP, clear the trip by rotating the knob counterclockwise to the OFF (O) position; then rotate knob clockwise to the ON (I) position. See [Figure 149](#).

**WARNING**

If an overload or a fault current interruption occurs, check circuits to determine the cause of the interruption. If a fault condition exists, examine the controller. If damaged, replace it to reduce the risk of fire or electrical shock.

### Other MMP Features:

- Three-position rotary operator: OFF (O)-TRIP-ON (I) ([Figure 149](#)).
- Lockout—tagoutable rotary operator: turn the rotary operator to OFF (O), slide out the extension arm, and insert a lockout pin.
- Ambient compensated  $-20^{\circ}\text{C}$  to  $+40^{\circ}\text{C}$ .
- Single-phase sensitivity: if one phase exceeds set point, all three phases open.
- Trip test: insert a 9/64" screw driver in the test slot ([Figure 149](#)) to simulate a trip.

**Figure 149: Manual Motor Protector**

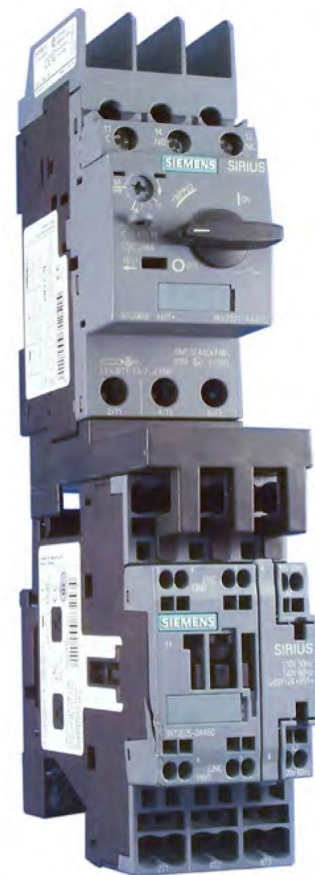

## Thermal Overload Relay

Designed to provide current-dependent protection for loads with normal starting against impermissibility high temperature rises due to overload, phase asymmetry or phase failure. Increase in motor current beyond set point as a result to overload or phase failure will trip the overload and disconnect the motor.

The Relay trip points are factory set. Do not change unless the motor ampacity changes or the Relay is replaced with a new device with incorrect set point adjustment. Any other non-authorized trip points or set points adjustment voids all or portions of the unit's warranty. Authorized set point adjustment is accomplishment as follows:

1. For motors with 1.15 service factor, rotate the arrow on the dial to correspond to the motor FLA (See Figure 150).
2. For motors with a 1.0 service factor, multiply the motor FLA with 0.9; then rotate the arrow on the dial to correspond to that value.

To reset a tripped Relay, push the blue RESET button. To disconnect, push the Red stop Button (See Figure 150).

Other Relay features:

- Three connection systems options, Screw type, spring loaded and ring cable lug connection.
- Switch position indicator to indicate a trip and TEST function for wiring.
- Large rotary button to adjust current to Motor RLA.
- Selector switch for manual/and automatic RESET.

Figure 150: Overload Relay



## Circuit Breaker

Circuit breakers are installed upstream of all VFDs to provide short circuit protection. These breakers are not adjustable.

To reset a tripped circuit breaker: Clear the trip by rotating the lever down to the OFF position (see Figure 151). Then rotate lever up to the ON position (Figure 151).

Breakers, like MMPs, have three distinct modes of operation which are clearly indicated by the handle position. The positions are ON (usually up, OFF (usually down), and TRIPPED (midway). Some circuit breakers may have a push-to-test button.

1. Press the handle or rotate the lever to the OFF position.
2. Press the handle or rotate the lever the opposite direction to the ON position.

### Reset After Tripping Information

**CAUTION**

If a breaker is tripped, the handle/lever will be halfway between the OFF and ON positions. To reset a tripped circuit breaker: Clear the trip by rotating the lever down to the OFF position (see Figure 151). Then rotate lever up to the ON position (Figure 151).

**WARNING**

If a circuit breaker has tripped due to an overload or a fault current (short circuit), prior to resetting, the connected wiring circuits must be checked to determine the cause of the interruption.

Figure 151: Circuit Breaker



## Field Wiring Terminals

All field wiring terminals are spring clamp type, which offer several advantages over traditional screw-type terminals:

- Spring connections do not require torquing.
- Spring connections resist failure due to vibration.
- Easily identifiable terminal markers.
- Combination spring release and square test ports Wire connections require inserting (“1” in Figure 152 a stripped wire a round port and clamping the stripped wire by inserting a flat-bladed screw driver in the adjacent square port (“2” in Figure 152).

Figure 152: Terminal Connectors

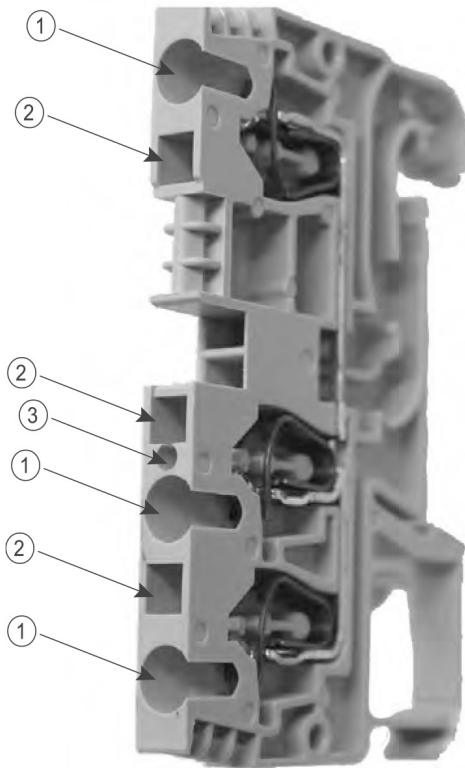

## Phase Voltage Monitor (PVM)

The phase voltage monitor (Figure 129) is designed to protect three-phase loads from damaging power conditions. A microprocessor-based voltage and phase sensing circuit constantly monitors the three-phase voltages to detect harmful power line conditions. When a harmful condition is detected, its output relay is deactivated after a specified trip delay (Trip Delay). The output relay reactivates after power line conditions return to an acceptable level for a specified amount of time (Restart Delay). The trip and restart delays prevent nuisance tripping due to rapidly fluctuating power line conditions.

There are two LEDs on the face of the PVM (“1” in Figure 129) to indicate the following:

Table 36: LED Indication

Status	LED Indicator
Normal operation, no faults, relay energized	Green LED: steady ON
Loss of input phase (relay de-energized)	Red LED: flash twice, OFF, flash twice, OFF, etc.
Voltage unbalance (relay de-energized)	Red LED: flash twice, OFF, flash twice, OFF, etc.
High or low voltage (relay de-energized)	Red LED: steady ON
Phase reversal (relay de-energized)	Red LED: pulse ON, OFF, ON, OFF, etc.
Restart delay (fault cleared, PVM pending restart, relay de-energized)	Green LED: pulse ON, OFF, ON, OFF, etc.

### Other features:

- Standard 2% to 8% variable voltage unbalance (“3” in Figure 153).
- Standard 1 to 500 second variable restart delay (“2” in Figure 153).
- Standard 1 to 30 second trip delay (“4” in Figure 153) (except loss of phase, which trips at 1 second nonadjustable).

Figure 153: Phase Voltage Monitor

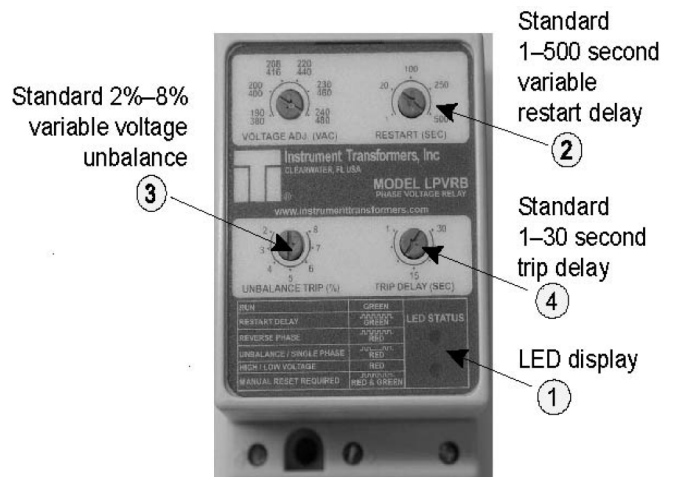

## Through-the-door Disconnect

**⚠ DANGER**

Hazardous voltage. May cause severe injury or death. Disconnect electric power before servicing equipment. More than one disconnect may be required to de-energize the unit.

**⚠ CAUTION**

Molded case switches do not provide over-current protection. This device may automatically open the circuit at levels above the ampere rating of the switch.

The optional “through-the-door” disconnect is a molded case switch with similar features of the circuit breaker. The “through-the-door” feature provides a safety interlock that disables power when the control panel door is opened. Opening the through-the-door disconnect without performing a proper machine shut-down is not recommended except in emergencies.

The through-the-door disconnect also provides for locking out power to the unit. To lock out power to the unit, rotate the handle to the “Reset/Lock” position and insert a padlock or locking device through the base of the handle. Do not lockout the handle with the Interlock in bypass mode.

*Figure 154: Through-the-door Handle Disconnect*



*Figure 155: Interlock Bypass*



## Controlled Shut-down/Interlock Bypass

To access the control panel while power is active, for troubleshooting or performing a controlled shut-down, the through-the-door disconnect's interlock feature can be bypassed. The control panel door can be opened without disabling power to the control panel.

1. Insert a flat blade screwdriver into the slotted "release" located on the end of the disconnect faceplate (Figure 131).
2. Turn the release counter-clockwise and pull the door open.
3. To shut down an operating unit (no emergency condition present):
  - a. Use the pump down switch to turn off the unit.
  - b. The controls will then shut the liquid line solenoids, pump the refrigerant into the condenser, and turn off the compressors.

## Pressure Sensors

The MicroTech controller uses 0 to 5" W.C. static pressure transducers for measuring duct static pressure. As the duct static pressure varies from 0-5" W.C., the transducer output will vary from 4-20mA. The transducer output signal is 420mA however the signal entering the VFD is converted to a DC signal via a 500 Ohm resistor across the output signal at the transducer.

If building static pressure control is provided, a -0.25" W.C. to 0.25" W.C. static pressure transducer is used. As the building static pressure varies from -0.25" W.C. to 0.25" W.C., the transducer output will vary from 4-20mA. The transducer output signal is 4-20mA however the signal entering the VFD is converted to a DC signal via a 500 Ohm resistor across the output signal at the transducer.

### Troubleshooting Pressure Transducers

Use the following procedure to troubleshoot a suspect sensor: If the duct static pressure always reads 0" WC on the unit keypad/display and the VFD speed is continuously ramping to 100%, check the following:

If the unit has two duct static pressure sensors (SPS1 and SPS2), verify that they both function properly per the following procedure. Also check for faulty wiring connections at the VFD analog inputs.

The controller displays and controls to the lower of the two readings. If a sensor is defective and inputs 0 volts to the VFD, the static pressure reading on the keypad/display reads 0 and the controller attempts to increase the 0 value to set point by ramping the VFD up.

If a second sensor (SPS2) is not installed or the pressure tubing to it is not connected, make sure the 2nd DSP Sensor= parameter in the Unit Configuration menu of the keypad/display is set to "No" so that the controller ignores the second static pressure analog input.

If a second sensor (SPS2) is installed, make sure the 2nd DSP Sensor= parameter in the Unit Configuration menu of the keypad/display is set to "Yes."

Check the 24 V (dc) power supply to the sensor, verify that there is 24 V (dc) between the suspect transducer "+" and "-" terminals.

Using an accurate manometer or gauge, measure the same pressure that the suspect transducer is sensing. To do this, tap into the transducer high and low pressure tubing or locate the measurement device taps next to the transducer taps.

If the suspect sensor is measuring duct static pressure, verify that the high and low pressure taps are properly installed. An improper pressure tap installation can cause severe fluctuations in the sensed pressure. Refer to the model-specific installation manual for pressure tap installation guidelines.

Measure the DC voltage output from the transducer across the sensor "S" and "-" terminals.

If the measured voltage and pressure do not match, there may be a wiring problem, the factory 500 ohm resistor across "S" and "-" or the transducer may be defective. Check the transducer input circuit wiring and connections for defects. If the measured voltage and pressure match, the VFD parameters and/or ModBus communication between the controller and the VFD will need to be verified.

Remove powers from the controller by opening system switch S1. If available, swap a similar good transducer with the suspect transducer or try installing a new transducer. Restore power by closing S1 and verify whether the suspect transducer is defective.

Component Designation	Description	Daikin Applied Part Number
MCB	Main Controller—must be programmed (unit GO# required)	193407301
NA	Connector, Extension I/O Direct Connect	193409701
NA	Terminal Block, MCB–2 Pole	193410302
NA	Terminal Block, MCB–3 Pole	193410303
NA	Terminal Block, MCB–5 Pole	193410305
NA	Terminal Block, MCB–6 Pole	193410306
NA	Terminal Block, MCB–7 Pole	193410307
NA	Terminal Block, MCB–8 Pole	193410308
EXP A	Expansion Module—Condenser/Energy Recovery	193407501
EXP B	Expansion Module—Heat	193407501
EXP C	Expansion Module—Specials	193407501
NA	Terminal Block, MCB–2 Pole	193410302
NA	Terminal Block, MCB–3 Pole	193410303
NA	Terminal Block, MCB–7 Pole	193410307
NA	Terminal Block, MCB–8 Pole	193410308
CCB1	Auxiliary Cooling Control Board (DX Circuit #1 or generic condenser)	112026101 (replaces 106102701)
CCB2	Auxiliary Cooling Control Board (DX Circuit #2)	112026101 (replaces 106102701)
EHB1	Auxiliary Electric Heat Control Board	112026101 (replaces 106102701)
ERB1	Auxiliary Energy Recovery Control Board	112026101 (replaces 106102801)
—	RS-485 Communication Module (for Auxiliary Control Boards)	060006202
—	Standoffs for mounting RS-485 Communication Module (PN 060006206) onto Auxiliary Control Board (PN 112026101)	048166707
—	Keypad/Display	060006301
—	Keypad–Main Control Board Cable	111044601
ZNT1	Zone Temperature Sensor with Tenant Override	111048101
	Zone Temperature Sensor with Tenant Override & Remote Set point Adjustment (SCC units only)	111048102
DAT	Discharge Air Temperature Sensor (50 ft cable length–field cut to length)	060004705
EFT	Entering Fan Air Temperature Sensor (50 ft cable length–field cut to length)	060004705
OAT	Outside Air Temperature Sensor (50 ft cable length–field cut to length)	060004705
RAT	Return Air Temperature Sensor (50 ft cable length–field cut to length)	060004705
SPS1	Static Pressure Sensor: Duct, No. 1	049545007
	Static Pressure Sensor: Duct, No. 2	049545007
SPS2	Static Pressure Sensor: Building (Space) Pressure	049545006
T2	Transformer: 115/24 V (ac)	060004601
T3	Transformer: 115/24 V (ac)	060004601
T9	Transformer: 115/24 V (ac)	060630801
HUM1	Humidity Sensor: Wall Mount	067294901
	Humidity Sensor: Duct Mount	067295001
PC5	Dirty Filter Switch: First Filter Section	065493801
PC6	Dirty Filter Switch: Final Filter Section	065493801
PC7	Airflow Proving Switch	060015801
DHL	Duct High Limit Switch	065493801
OAE	Enthalpy Control: Electromechanical	030706702
	Enthalpy Control: Electronic (Used with RAE)	049262201
RAE	Return Air Enthalpy Sensor (Used with Electronic OAE)	049262202
SD1	Smoke Detector: Supply Air	049025001
SD2	Smoke Detector: Return Air	049025001
—	BACnet MS/TP Communication Module (RS485)	090016710
—	BACnet/IP Communication Module (Ethernet Cable 10BASET)	090016709
—	LonMark Space Comfort Controller (SCC) Communication Module	090016712
—	LonMark Discharge Air Controller (DAC) Communication Module	090016711
—	5 V (dc) Power Supply	111049601
—	Serial Port Ribbon	111047201
—	MCB Battery	BR2325
—	MCB Connector Repair Kit	300036605
—	Power Disconnect Switch	033696300
—	18 in. Lamp Holder	205484001
—	24 in. Lamp Holder	205484101
—	36 in. Lamp Holder	205484201
—	Hard Wire Module	205485501
—	18 in. Lamp	205484501
—	24 in. Lamp	205484601
—	36 in. Lamp	205484701



## Replacement Parts

When writing to Daikin Applied for service or replacement parts, provide the model number, serial number, and unit part number of the unit as stamped on the serial plate attached to the unit. For questions regarding wiring diagrams, it will be necessary to provide the number on the specific diagram. If replacement parts are required, include the date of unit installation, the date of failure, an explanation of the malfunction, and a description of the replacement parts required.

## Scroll Compressor

Daikin Applied Rooftops use the following Copeland Scroll Compressors.

1. Tandem compressors, basically two compressors specifically manufactured by Copeland into a single assembly.
2. Trio compressors, basically three single compressors factory piped in parallel with equalization lines.

All Daikin Applied Rooftop products include a first-year parts only warranty. The warranty period extends 12 months from startup or 18 months from date of shipment, whichever comes first. Labor to install these parts is not included with this warranty. Compressors are considered a part and are included in this standard warranty.

Scroll service replacement compressors for Daikin Applied Rooftop Units can be obtained from the following two sources:

- Daikin Applied Service Parts maintains a stock of replacement compressors.
- Copeland Refrigeration has stocking wholesalers throughout the U.S. who maintain a limited stock of replacement scroll compressors. Copeland does offer quick ship options through their wholesalers. However, if a portion of a tandem or trio is being replaced, Copeland cannot provide the piping kit, so labor will be more difficult (See [Scroll Compressor Piping on page 126.](#))

Both sources can be used, at the customer's discretion, within the first year warranty and with the following limitations.

1. RPS 035D to 068D—Only the failed portion of the tandem may need replacement.
2. RPS 070D to 140D—Only the failed portion of the trio may need replacement.

## Replacing a Portion of a Tandem or Trio

The decision to replace the failed portion of the tandem or trio, as opposed to replacing the entire tandem or trio, must be decided based on the following.

1. In warranty: Warranty only covers replacement of the failed portion of the tandem or trio. Either source may be used.
2. Out of warranty: The customer decides whether to replace the entire tandem/trio or just a portion and either source may be used.

When replacing an "in warranty" compressor through a Copeland Wholesaler, take the failed compressor to the wholesaler for an over-the-counter or an advanced replacement exchange. Credit is issued by Copeland on the returned motor compressor upon receipt and factory inspection of the inoperative motor compressor. In this transaction, be certain that the motor compressor is definitely defective. If a motor compressor is received from the field that tests satisfactorily, a service charge plus a transportation charge will be charged against its original credit value.

If there was a delay in the startup of the equipment and the first-year warranty (Copeland) has expired on the compressor, within the 18-month-from-shipment warranty, order the replacement compressor through the Daikin Applied Parts Department (Minneapolis).

1. Contact the Daikin Applied Parts Department for compressor availability.
2. Send a completed parts order form to the Daikin Applied Parts Department.
3. The Parts Department processes the order and the compressor is shipped from our Dayton, OH warehouse via ground transportation. If next-day air is required, indicate this on the parts order form and a freight charge will be billed to your account. Air freight costs are not covered under the Daikin Applied warranty.
4. After the failed compressor is replaced, return it to Daikin Applied with a Return Goods Tag attached, which you will receive in the mail. It must be attached to the compressor. The Return Goods Tag has instructions on where to send the compressor. If the compressor is not returned, you will be billed for the replacement compressor.
5. Consideration may be given at this time to a compressor teardown analysis, depending on the history of failures.

On Daikin Applied equipment that includes the extended 2nd -5th year compressor warranty option, the replacement compressor must be ordered through the Daikin Applied Parts Department (Minneapolis).

1. Contact the Daikin Applied Parts Department for compressor availability.
2. Send the Daikin Applied Parts Department a completed parts order form.
3. The Parts Department will process the order and the compressors will be shipped from our Dayton, OH warehouse via ground transportation. If next-day air is required, you will need to indicate this on the parts order form and a freight charge will be billed to your account. Air freight costs are not covered under the Daikin Applied warranty.
4. After the failed compressor has been replaced, it must be returned to Daikin Applied with a Return Goods Tag attached. You will receive the tag in the mail and it must be attached to the compressor. The Return Goods Tag will have instructions on where to send the compressor. If the compressor is not returned, you will be billed for the replacement compressor.
5. Consideration may be given at this time to a compressor teardown analysis, depending on the history of failures.

## **In-Warranty Return Material Procedure**

Material other than compressors may not be returned except by permission of authorized factory service personnel of Daikin Applied at Minneapolis, Minnesota.

A "return goods" tag will be sent to be included with the returned material. Enter the information as called for on the tag in order to expedite handling at our factories and issuance of credits. All parts shall be returned to the factory designated on the return goods tag, transportation charges prepaid.

The return of the part does not constitute an order for replacement. A purchase order for the replacement part must be entered through your nearest Daikin Applied representative. The order should include the component's part number and description and the model and serial numbers of the unit involved.

If it is determined that the failure of the returned part is due to faulty material or workmanship within the standard warranty period, credit will be issued on the customer's purchase order.



DAIKIN APPLIED AMERICAS INC.  
LIMITED PRODUCT WARRANTY  
(United States and Canada)

**WARRANTY**

Daikin Applied Americas Inc. dba Daikin Applied ("Company") warrants to contractor, purchaser and any owner of the product (collectively "Owner") that, subject to the exclusions set forth below Company, at its option, will repair or replace defective parts in the event any product manufactured by Company, including products sold under the brand name Daikin and used in the United States or Canada, proves defective in material or workmanship within twelve (12) months from initial startup or eighteen (18) months from the date shipped by Company, whichever occurs first. Authorized replacement parts are warranted for the remainder of the original warranty. All shipments of such parts will be made FOB factory, freight prepaid and allowed. Company reserves the right to select carrier and method of shipment. In addition, Company provides labor to repair or replace warranty parts during Company normal working hours on products with rotary screw compressors or centrifugal compressors. Warranty labor is not provided for any other products.

Company must receive the Registration and Startup Forms for products containing motor compressors and/or furnaces within ten (10) days of original product startup, or the ship date and the startup date will be deemed the same for determining the commencement of the warranty period and this warranty shall expire twelve (12) months from that date. For additional consideration, Company will provide an extended warranty(ies) on certain products or components thereof. The terms of the extended warranty(ies) are shown on a separate extended warranty statement.

No person (including any agent, sales representative, dealer or distributor) has the authority to expand the Company's obligation beyond the terms of this express warranty or to state that the performance of the product is other than that published by Company.

**EXCLUSIONS**

1. If free warranty labor is available as set forth above, such free labor does not include diagnostic visits, inspections, travel time and related expenses, or unusual access time or costs required by product location.
2. Refrigerants, fluids, oils and expendable items such as filters are not covered by this warranty.
3. This warranty shall not apply to products or parts : (a) that have been opened, disassembled, repaired, or altered, in each case by anyone other than Company or its authorized service representative; (b) that have been subjected to misuse, abuse, negligence, accidents, damage, or abnormal use or service; (c) that have not been properly maintained; (d) that have been operated or installed, or have had startup performed, in each case in a manner contrary to Company's printed instructions; (e) that have been exposed, directly or indirectly, to a corrosive atmosphere or material such as, but not limited to, chlorine, fluorine, fertilizers, waste water, urine, rust, salt, sulfur, ozone, or other chemicals, contaminants, minerals, or corrosive agents; (f) that were manufactured or furnished by others and/or are not an integral part of a product manufactured by Company; or (g) for which Company has not been paid in full.
4. This warranty shall not apply to products with rotary screw compressors or centrifugal compressors if such products have not been started, or if such startup has not been performed, by a Daikin Applied or Company authorized service representative.

**SOLE REMEDY AND LIMITATION OF LIABILITY**

THIS WARRANTY CONSTITUTES THE SOLE WARRANTY MADE BY COMPANY. COMPANY'S LIABILITY TO OWNER AND OWNER'S SOLE REMEDY UNDER THIS WARRANTY SHALL NOT EXCEED THE LESSER OF: (i) THE COST OF REPAIRING OR REPLACING DEFECTIVE PRODUCTS; AND (ii) THE ORIGINAL PURCHASE PRICE ACTUALLY PAID FOR THE PRODUCTS. COMPANY MAKES NO REPRESENTATION OR WARRANTY, EXPRESS OR IMPLIED, REGARDING PREVENTION OF MOLD/MOULD, FUNGUS, BACTERIA, MICROBIAL GROWTH, OR ANY OTHER CONTAMINATES. THIS WARRANTY IS GIVEN IN LIEU OF ALL OTHER WARRANTIES, INCLUDING, WITHOUT LIMITATION, THE IMPLIED WARRANTIES OF MERCHANTABILITY, FITNESS FOR A PARTICULAR PURPOSE, AND NON-INFRINGEMENT, WHICH ARE HEREBY DISCLAIMED. IN NO EVENT AND UNDER NO CIRCUMSTANCE SHALL COMPANY BE LIABLE TO OWNER OR ANY THIRD PARTY FOR INCIDENTAL, INDIRECT, SPECIAL, CONTINGENT, CONSEQUENTIAL, DELAY OR LIQUIDATED DAMAGES FOR ANY REASON, ARISING FROM ANY CAUSE WHATSOEVER, WHETHER THE THEORY FOR RECOVERY IS BASED IN LAW OR IN EQUITY, OR IS UNDER A THEORY OF BREACH CONTRACT OR WARRANTY, NEGLIGENCE, STRICT LIABILITY, OR OTHERWISE. THE TERM "CONSEQUENTIAL DAMAGE" INCLUDES, WITHOUT LIMITATION, THOSE DAMAGES ARISING FROM BUSINESS INTERRUPTION OR ECONOMIC LOSS, SUCH AS LOSS OF ANTICIPATED PROFITS, REVENUE, PRODUCTION, USE, REPUTATION, DATA OR CROPS.

**ASSISTANCE**

To obtain assistance or information regarding this warranty, please contact your local sales representative or a Daikin Applied office.

Form No. 933-430285Y-01-A (11/2023)  
Part No. 043028500 Rev.0F



## Rooftop Equipment Warranty Registration Form

To comply with the terms of Daikin Applied Warranty, complete and return this form within 10 days to the Warranty Department of Daikin Applied.

Check, test, and start procedure for Rooftop roof mounted air conditioners with or without heat recovery and roof mounted air handlers.

### GENERAL INFORMATION

Job Name: \_\_\_\_\_ Unit No.: \_\_\_\_\_

SOI No.: \_\_\_\_\_

Installation address: \_\_\_\_\_

City: \_\_\_\_\_ State: \_\_\_\_\_

Purchasing contractor: \_\_\_\_\_

City: \_\_\_\_\_ State: \_\_\_\_\_

Name of person doing start-up: \_\_\_\_\_

Company name: \_\_\_\_\_

Address: \_\_\_\_\_

City/State/Zip: \_\_\_\_\_

### UNIT INFORMATION

Unit model number: \_\_\_\_\_ Unit serial number: \_\_\_\_\_

Compressor 1 model number: \_\_\_\_\_ Serial number: \_\_\_\_\_

Compressor 2 model number: \_\_\_\_\_ Serial number: \_\_\_\_\_

Compressor 3 model number: \_\_\_\_\_ Serial number: \_\_\_\_\_

Compressor 4 model number: \_\_\_\_\_ Serial number: \_\_\_\_\_

Compressor 5 model number: \_\_\_\_\_ Serial number: \_\_\_\_\_

Compressor 6 model number: \_\_\_\_\_ Serial number: \_\_\_\_\_

**Rooftop Equipment Warranty Registration Form (continued)***Select Yes or No. If not applicable to the type of unit, select N/A.***I. INITIAL CHECK**

- A. Is any shipping damage visible? . . . . .  Yes  No  N/A
- B. Are fan drives properly aligned and belts properly adjusted? . . . . .  Yes  No  N/A
- C. Tightened all setscrews on pulleys, bearings and fans? . . . . .  Yes  No  N/A
- D. Have the hold-down bolts been backed off on spring mounted fan isolators? . . . . .  Yes  No  N/A
- E. Do fans turn freely? . . . . .  Yes  No  N/A
- F. Has the discharge static pressure reference line been properly located within the building? . . . . .  Yes  No  N/A
- G. Electrical service corresponds to unit nameplate? . . . . .  Yes  No  N/A

G1. Voltage at Terminal Block | Disconnect                      1-2 \_\_\_\_\_ V    2-3 \_\_\_\_\_ V    1-3 \_\_\_\_\_ V

- H. Is the main disconnect adequately fused and are fuses installed? . . . . .  Yes  No  N/A
- I. Are crankcase heaters operating, and have they been operating 24 hours prior to start-up? . . . . .  Yes  No  N/A
- J. Are all electrical power connections tight? (Check compressor electrical box.) . . . . .  Yes  No  N/A
- K. Is the condensate drain trapped? . . . . .  Yes  No  N/A

**II. FAN DATA**

- A. Check rotation of supply fan? . . . . .  Yes  No  N/A
- B. Voltage at supply fan motor: . . . . . 1-2 \_\_\_\_\_ V    2-3 \_\_\_\_\_ V    1-3 \_\_\_\_\_ V
- C. Supply fan motor amp draw per phase: . . . . . L1 \_\_\_\_\_ L2 \_\_\_\_\_ L3 \_\_\_\_\_
- D. Fuse sizes: . . . . . \_\_\_\_\_
- E. What is the supply fan rpm? . . . . . \_\_\_\_\_
- F. Check rotation of return fan? . . . . .  Yes  No  N/A
- G. Voltage at return fan motor: . . . . . 1-2 \_\_\_\_\_ V    2-3 \_\_\_\_\_ V    1-3 \_\_\_\_\_ V
- H. Return fan motor amp draw per phase: . . . . . L1 \_\_\_\_\_ L2 \_\_\_\_\_ L3 \_\_\_\_\_
- I. Fuse sizes: . . . . . \_\_\_\_\_
- J. What is the return fan rpm? . . . . . \_\_\_\_\_
- K. Record supply static pressure at unit in inches of H<sub>2</sub>O: . . . . . \_\_\_\_\_
- L. Record return static pressure at unit (with outside air dampers closed) in inches of H<sub>2</sub>O: . . . . . \_\_\_\_\_



**Rooftop Equipment Warranty Registration Form (continued)**

Select Yes or No. If not applicable to the type of unit, select N/A.

**III. START-UP COMPRESSOR OPERATION**

- A. Do compressors have holding charges?
  - Circuit #1. . . . .  Yes  No  N/A
  - Circuit #2. . . . .  Yes  No  N/A
- B. Are compressors rotating in the right direction? . . . . .  Yes  No  N/A
- C. Do condenser fans rotate in the right direction? . . . . .  Yes  No  N/A
- D. Ambient temperature (°F): . . . . . \_\_\_\_\_
- E. Does unit start up and perform per sequence of operation? . . . . .  Yes  No  N/A

**IV. PERFORMANCE DATA**

- A. Compressor voltage across each phase: . . . . . 1-2 \_\_\_\_\_ V 2-3 \_\_\_\_\_ V 1-3 \_\_\_\_\_ V
- B. Compressor amperage of fully loaded compressor:
  - Compressor #1 — Phase 1 \_\_\_\_\_ Phase 2 \_\_\_\_\_ Phase 3 \_\_\_\_\_
  - Compressor #2 — Phase 1 \_\_\_\_\_ Phase 2 \_\_\_\_\_ Phase 3 \_\_\_\_\_
  - Compressor #3 — Phase 1 \_\_\_\_\_ Phase 2 \_\_\_\_\_ Phase 3 \_\_\_\_\_
  - Compressor #4 — Phase 1 \_\_\_\_\_ Phase 2 \_\_\_\_\_ Phase 3 \_\_\_\_\_
  - Compressor #5 — Phase 1 \_\_\_\_\_ Phase 2 \_\_\_\_\_ Phase 3 \_\_\_\_\_
  - Compressor #6 — Phase 1 \_\_\_\_\_ Phase 2 \_\_\_\_\_ Phase 3 \_\_\_\_\_
- C. Low pressure cut-out: . . . . . Circuit 1 \_\_\_\_\_ psig Circuit 2 \_\_\_\_\_ psig
- D. Low pressure cut-in: . . . . . Circuit 1 \_\_\_\_\_ psig Circuit 2 \_\_\_\_\_ psig
- E. High pressure cut-out: . . . . . Circuit 1 \_\_\_\_\_ psig Circuit 2 \_\_\_\_\_ psig
- F. Discharge pressure, one compressor: . . . . . Circuit 1 \_\_\_\_\_ psig Circuit 2 \_\_\_\_\_ psig
- G. Discharge pressure, fully loaded, 2-3 compressors: . . . . . Circuit 1 \_\_\_\_\_ psig Circuit 2 \_\_\_\_\_ psig
- H. Suction pressure, one compressor: . . . . . Circuit 1 \_\_\_\_\_ psig Circuit 2 \_\_\_\_\_ psig
- I. Suction pressure, fully loaded, 2-3 compressors: . . . . . Circuit 1 \_\_\_\_\_ psig Circuit 2 \_\_\_\_\_ psig
- J. Liquid press, fully loaded, 2-3 compressors (at liquid line shutoff valve): . . . . . Circuit 1 \_\_\_\_\_ psig Circuit 2 \_\_\_\_\_ psig
- K. Liquid temperature, fully loaded, 2-3 compressors: . . . . . Circuit 1 \_\_\_\_\_ psig Circuit 2 \_\_\_\_\_ psig
- L. Suction line temperature: . . . . . \_\_\_\_\_ °F \_\_\_\_\_ °F
- M. Superheat: . . . . . \_\_\_\_\_ °F \_\_\_\_\_ °F
- N. Subcooling: . . . . . \_\_\_\_\_ °F \_\_\_\_\_ °F
- O. Is the liquid in the line sightglass clear and dry? . . . . .  Yes  No  N/A
- P. Does the hot gas bypass valve function properly? . . . . .  Yes  No  N/A



Rooftop Equipment Warranty Registration Form (continued)

Select Yes or No. If not applicable to the type of unit, select N/A.

- Q. At what suction pressure does the hot gas bypass valve open? . . . . . Circuit 1 \_\_\_\_\_ psig Circuit 2 \_\_\_\_\_ psig
R. Record discharge air temperature at discharge of unit: \_\_\_\_\_ °F
S. Are all control lines secure to prevent excessive vibration and wear? . . . . .  Yes  No  N/A
T. Are all gauges shut off and valve caps and packings tight after start-up? . . . . .  Yes  No  N/A

V. ELECTRIC HEAT CHECK, TEST & START

- A. Electrical heat service corresponds to unit nameplate? . . . . .  Yes  No  N/A
Volts \_\_\_\_\_ Hertz \_\_\_\_\_ Phase \_\_\_\_\_
B. Are there any signs of physical damage to the electric heat coils? . . . . .  Yes  No  N/A
C. Have all electrical terminals been tightened? . . . . .  Yes  No  N/A
D. Does sequence controller stage contactors properly? . . . . .  Yes  No  N/A
E. Electric heater voltage across each phase: . . . . . \_\_\_\_\_ L1 \_\_\_\_\_ L2 \_\_\_\_\_ L3
F. Amp draw across each phase at each heating stage:
Stage 1 Stage 2 Stage 3 Stage 4 Stage 5 Stage 6
Phase L1: \_\_\_\_\_
Phase L2: \_\_\_\_\_
Phase L3: \_\_\_\_\_
G. FLA: . . . . . L1 \_\_\_\_\_ L2 \_\_\_\_\_ L3 \_\_\_\_\_
H. Operate electric heat with fans off. Electric heat must cycle on high limit control . . . . .  Yes  No  N/A

VI. GAS BURNER CHECK, TEST, & START

Specifications:

For gas, see Forced Draft Gas Burner Installation and Maintenance Bulletin. (IM 684 and IM 685)

- A. Gas Furnace: . . . . . Model no. \_\_\_\_\_
B. Gas Burner: . . . . . Model no. \_\_\_\_\_ Serial no. \_\_\_\_\_
C. Gas Rated firing rate (MBH input): . . . . . \_\_\_\_\_
D. Gas Altitude (ft. above sea level): . . . . . \_\_\_\_\_
E. Input (CFH): . . . . . \_\_\_\_\_
F. Gas pressure at burner (inches w.c.): . . . . . \_\_\_\_\_
G. CO2 (%): . . . . . \_\_\_\_\_
H. CO2 (%): . . . . . \_\_\_\_\_
I. Pilot flame only in microamps (steady at low fire): . . . . . \_\_\_\_\_
J. Pilot Tap-gas pressure (inches w.c.): . . . . . \_\_\_\_\_
K. Motor only/burner FLA running amps: . . . . . \_\_\_\_\_
L. High limit control OK? . . . . .  Yes  No  N/A
M. Flame safeguard (microamps): . . . . . \_\_\_\_\_

**Rooftop Equipment Warranty Registration Form (continued)***Select Yes or No. If not applicable to the type of unit, select N/A.*

N. Flame failure shutoff (seconds): . . . . . \_\_\_\_\_

O. Airswitch OK? . . . . .  Yes  No  N/AP. High Gas Pressure Switch OK? . . . . .  Yes  No  N/AQ. Low Gas Pressure Switch OK? . . . . .  Yes  No  N/AR. Main Gas Valve Close-off OK? . . . . .  Yes  No  N/A

S. Modulation Gas Heat Performance

**Gas Pressure****Mod. Valve****Reg. Valve**

25% \_\_\_\_\_ in Wc.      25% \_\_\_\_\_ in Wc.

50% \_\_\_\_\_ in Wc.      50% \_\_\_\_\_ in Wc.

75% \_\_\_\_\_ in Wc.      75% \_\_\_\_\_ in Wc.

100% \_\_\_\_\_ in Wc.      100% \_\_\_\_\_ in Wc.

**VII. Hot Water Coil**A. Pressure test OK? . . . . .  Yes  No  N/A**VIII. Heat Recovery**A. Heat wheel rotates freely? . . . . .  Yes  No  N/AB. Heat wheel VFD operates properly? . . . . .  Yes  No  N/A

C. Heat wheel VFD . . . . . Model No. \_\_\_\_\_ Serial No. \_\_\_\_\_

D. Check for air bypass around heat wheel. . . . .  Yes  No  N/A**IX. Design Flow Calibration**A. Verify power is supplied to the MicroTech III unit controller . . . . .  Yes  No  N/AB. Verify that the shipping screws have been removed from the measuring station vane . . . . .  Yes  No  N/AC. Examine station for damage . . . . .  Yes  No  N/A

D. Record Level Position after calibration

• LH Level Position . . . . . \_\_\_\_\_

• RH Level Position . . . . . \_\_\_\_\_

NOTE: This is viewed in the MicroTech III controller, in the Min OA setup menu.



**Rooftop Equipment Warranty Registration Form (continued)**

Select Yes or No. If not applicable to the type of unit, select N/A.

X. Have all electronic or electrical controls been checked, adjusted, and tested for proper operation per the installation and maintenance bulletins?

.....  Yes  No  N/A

**XI. MAINTAINING MICROTECH CONTROL PARAMETER RECORDS**

After the unit is checked, tested, and started and the final control parameters are set, record the final settings. Keep these records on file and update whenever changes to the control parameters are made. Keeping a record facilitates any required analysis and troubleshooting of the system operation and facilitates restoration after a controller replacement.

Thank you for completing this form. Please sign and date below.

Signature \_\_\_\_\_ Startup date: \_\_\_\_\_

**Return completed form by mail to:**

Daikin Warranty Department, 13600 Industrial Park Boulevard, Minneapolis, MN 55441

or by email to: [AAHWarrantyStartup@daikinapplied.com](mailto:AAHWarrantyStartup@daikinapplied.com)

Please fill out the Daikin Applied "Quality Assurance Survey Report" and list any additional comments that could affect the operation of this unit; e.g., shipping damage, failed components, adverse installation applications, etc. If additional comment space is needed, write the comment(s) on a separate sheet, attach it to the Survey Report and return it to the Warranty Department of Daikin Applied with the completed Equipment Warranty Registration form.

**Submit Form**

**Clear Form**

**Quality Assurance Survey Report**

To whom it may concern:

Please review the items below upon receiving and installing our product. Select N/A on any item that does not apply to the product.

**Job Name:** \_\_\_\_\_ **Daikin Applied S.O. No.** \_\_\_\_\_

Installation address: \_\_\_\_\_

City: \_\_\_\_\_ State: \_\_\_\_\_

Purchasing contractor: \_\_\_\_\_

City: \_\_\_\_\_ State: \_\_\_\_\_

**Name of person doing start-up (print):** \_\_\_\_\_

Company name: \_\_\_\_\_

Address: \_\_\_\_\_

City/State/Zip: \_\_\_\_\_

**Unit model number:** \_\_\_\_\_ **Unit serial number:** \_\_\_\_\_1. Is there any shipping damage visible? ..... Yes  No  N/A 

Location on unit \_\_\_\_\_

2. How would you rate the overall appearance of the product; i.e., paint, fin damage, etc.? Excellent  Good  Fair  Poor 3. Did all sections of the unit fit together properly? ..... Yes  No  N/A 4. Did the cabinet have any air leakage? ..... Yes  No  N/A 

Location on unit \_\_\_\_\_

5. Were there any refrigerant leaks? ..... Yes  No  N/A From where did it occur? ..... Shipping  Workmanship  Design 6. Does the refrigerant piping have excessive vibration? ..... Yes  No  N/A 

Location on unit \_\_\_\_\_

7. Did all of the electrical controls function at start-up? ..... Yes  No  N/A 

Comments \_\_\_\_\_

8. Did the labeling and schematics provide adequate information? ..... Yes  No  N/A 9. How would you rate the serviceability of the product? Excellent  Good  Fair  Poor 10. How would you rate the overall quality of the product? Excellent  Good  Fair  Poor 11. How does the quality of Daikin Applied products rank in relation to competitive products? Excellent  Good  Fair  Poor 

Comments \_\_\_\_\_

Please list any additional comments which could affect the operation of this unit; i.e., shipping damage, failed components, adverse installation applications, etc. If additional comment space is needed, write the comment(s) on a separate sheet, attach the sheet to this completed Quality Assurance Survey Report, and return it to the Warranty Department with the completed preceding "Equipment Warranty Registration Form".





### ***Daikin Applied Training and Development***

Now that you have made an investment in modern, efficient Daikin equipment, its care should be a high priority. For training information on all Daikin HVAC products, please visit us at [www.DaikinApplied.com](http://www.DaikinApplied.com) and click on Training, or call 540-248-9646 and ask for the Training Department.

### ***Warranty***

All Daikin Applied equipment is sold pursuant to its standard terms and conditions of sale, including Limited Product Warranty. Consult your local Daikin Applied representative for warranty details. To find your local Daikin Applied representative, go to [www.DaikinApplied.com](http://www.DaikinApplied.com).

### ***Aftermarket Services***

To find your local parts office, visit [www.DaikinApplied.com](http://www.DaikinApplied.com) or call 800-37PARTS (800-377-2787). To find your local service office, visit [www.DaikinApplied.com](http://www.DaikinApplied.com) or call 800-432-1342.

This document contains the most current product information as of this printing. For the most up-to-date product information, please go to [www.DaikinApplied.com](http://www.DaikinApplied.com).

Products manufactured in an ISO Certified Facility.